



US00D351129S

# United States Patent [19]

[11] Patent Number: Des. 351,129

Templeman

[45] Date of Patent: \*\* Oct. 4, 1994

- [54] **BOAT STABILIZER**
- [75] Inventor: **Arthur R. Templeman**, Overland Park, Kans.
- [73] Assignee: **Marine Dynamics, Inc.**, Overland Park, Kans.
- [\*] Notice: The portion of the term of this patent subsequent to Feb. 4, 2008 has been disclaimed.
- [\*\*] Term: **14 Years**
- [21] Appl. No.: **476,029**
- [22] Filed: **Feb. 6, 1990**

4,205,618	6/1980	Olsson	114/281
4,323,355	4/1982	Kondo	440/76
4,487,152	12/1984	Larson	114/274
4,597,742	7/1986	Finkl	440/61
4,708,672	11/1987	Bentz	440/51
4,738,644	4/1988	Happel	440/900
4,744,779	5/1988	Koehler	440/900
4,756,265	7/1988	Lane	114/57
4,977,847	12/1990	Bartlett	114/274

### FOREIGN PATENT DOCUMENTS

226596	5/1969	Sweden
716879	10/1954	United Kingdom

### OTHER PUBLICATIONS

A brochure entitled "Stingray™ Hydrofoil Stabilizer", published by Marine Dynamics, Inc. beginning in 1988.

An article entitled "DOEL-FIN-Not Just Another Gadget", dated Jul., 1979.

An advertisement entitled "Hydrofoil G.T.™", published by Hydrofoil International Corp. in Jun. of 1989.

*Primary Examiner*—Kay H. Chin

*Attorney, Agent, or Firm*—Dougherty, Hessin, Beavers & Gilbert

### Related U.S. Application Data

- [63] Continuation-in-part of Ser. No. 210,697, Jun. 23, 1988, Pat. No. D. 308,851.
- [52] U.S. Cl. .... **D12/317**
- [58] Field of Search ..... 114/274, 284, 280, 281, 114/285, 286, 287; D12/317, 318; D21/230

### References Cited

#### U.S. PATENT DOCUMENTS

D. 311,513	10/1990	Templeman	D12/317
2,021,309	11/1935	Irgens	115/17
2,319,640	5/1943	Sink	115/42
2,963,000	12/1960	Fester	115/42
2,998,795	9/1961	Downie et al.	114/145
3,099,240	7/1963	Montague, Jr.	114/66.5
3,114,343	12/1963	Headrick et al.	114/66.5
3,139,853	7/1964	McCarthy et al.	115/17
3,211,119	10/1965	Kiekhaefer	114/66.5
3,343,512	9/1967	Rasmussen	114/66.5
3,433,195	3/1969	Poole	114/66.5
3,765,356	10/1973	Cook	114/66.5
3,964,417	6/1976	Williams et al.	114/66.5
4,040,373	8/1977	Jones, Jr.	114/126

### CLAIM

[57] The ornamental design for a boat stabilizer, or the like, as shown and described.

### DESCRIPTION

FIG. 1 is a perspective view of a boat stabilizer or the like showing my new design;  
 FIG. 2 is a top plan view thereof;  
 FIG. 3 is a bottom plan view thereof;  
 FIG. 4 is a front elevational view thereof;  
 FIG. 5 is a left side elevational view thereof;  
 FIG. 6 is a right side elevational view thereof; and,  
 FIG. 7 is a rear elevational view thereof.

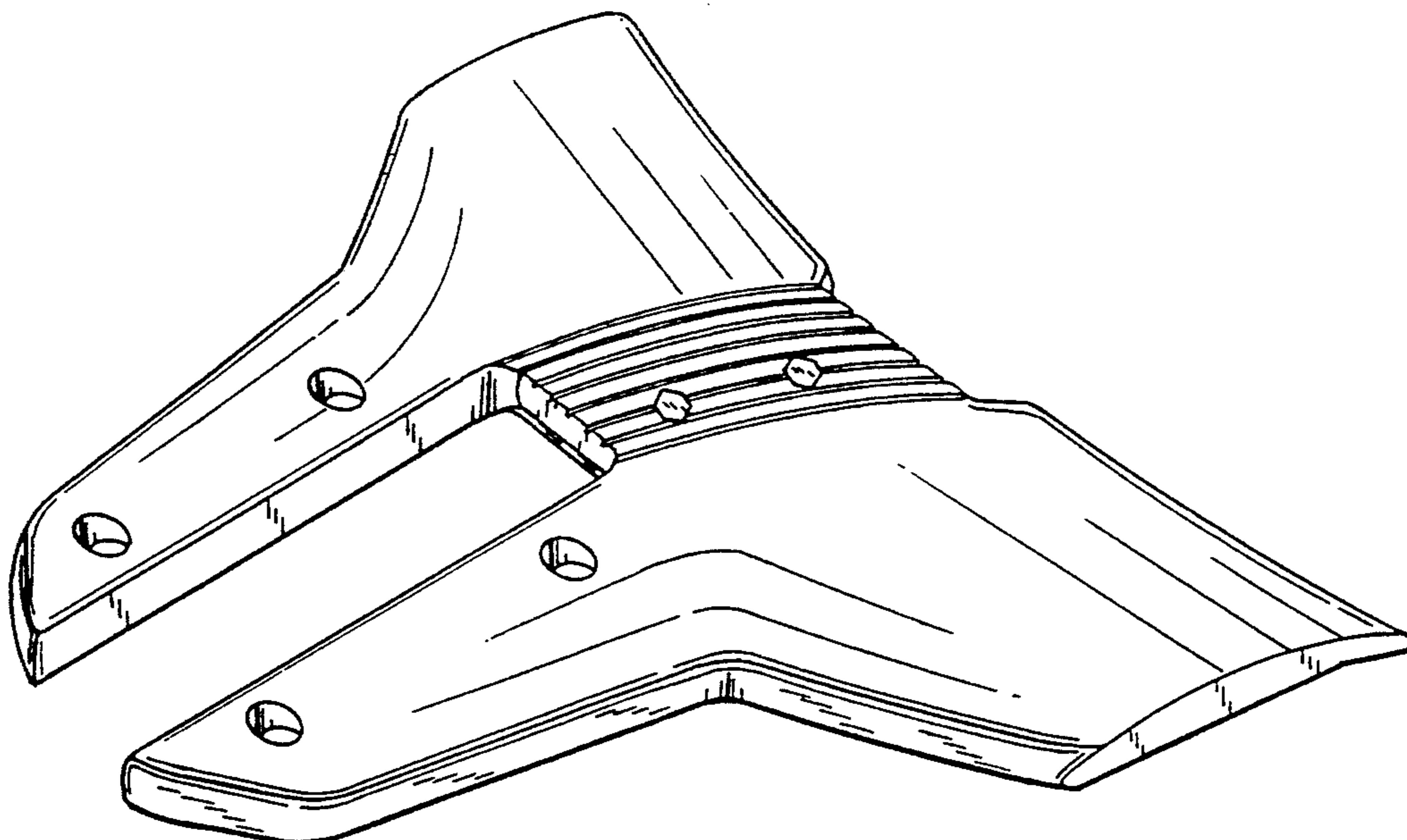

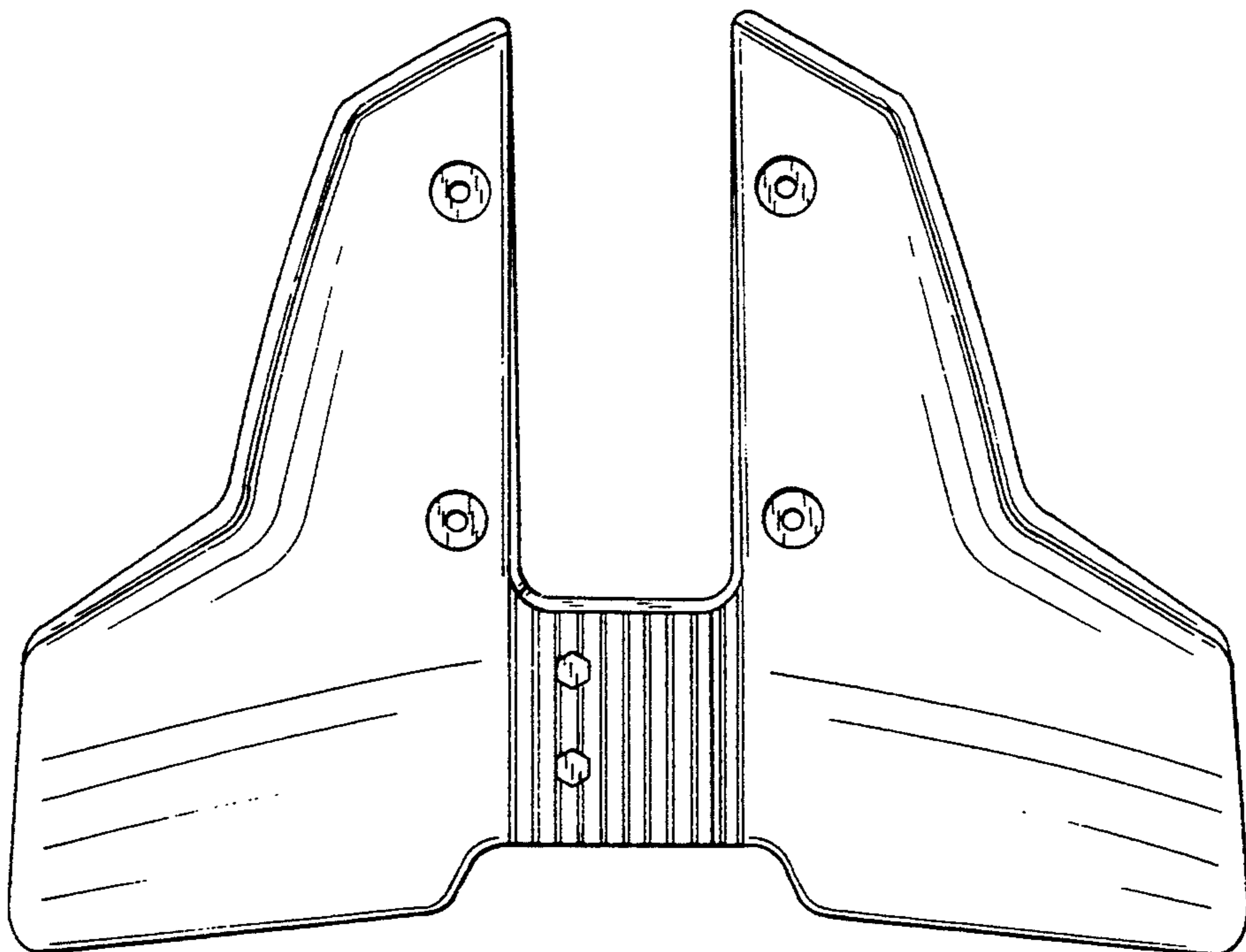
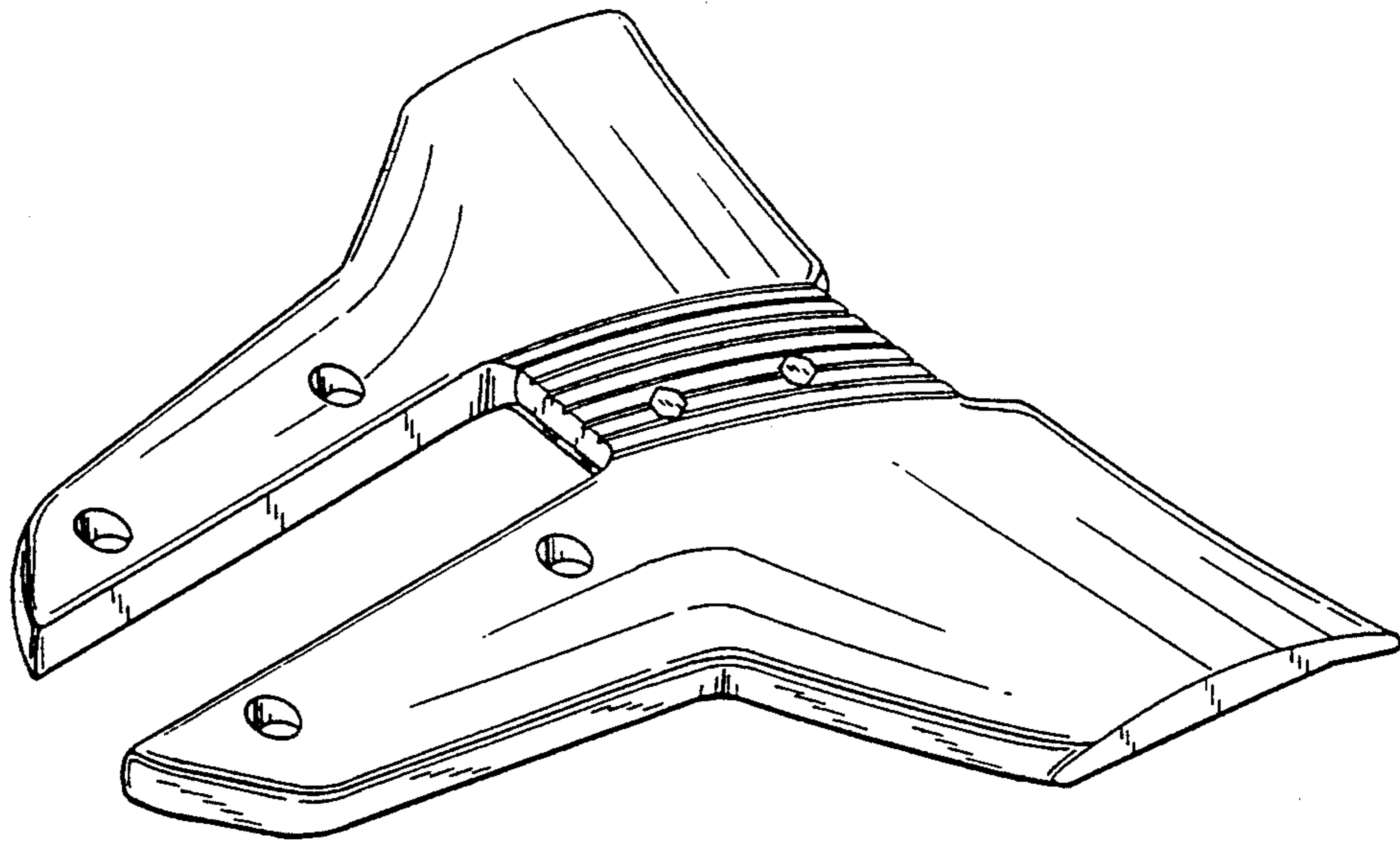

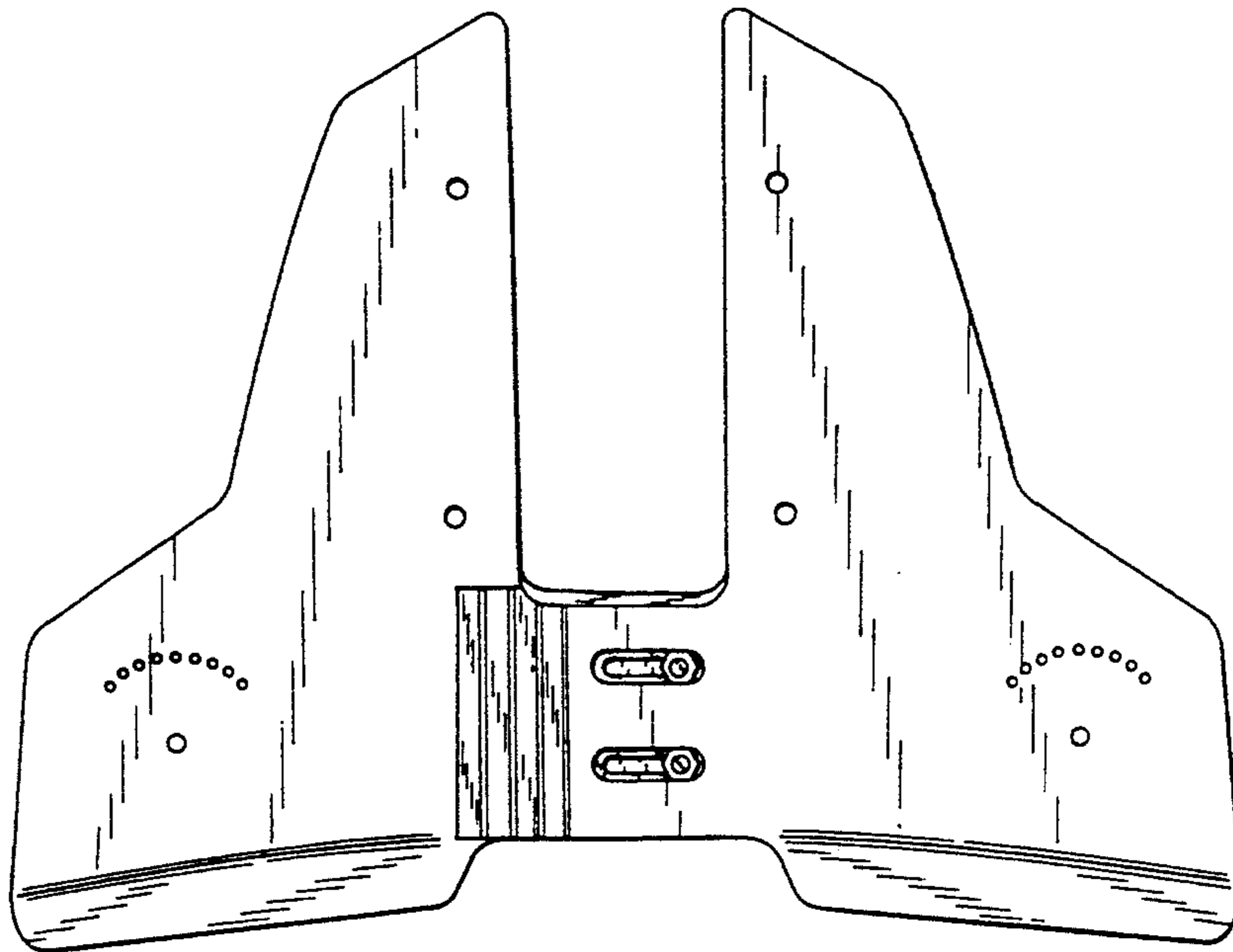

FIG. 1

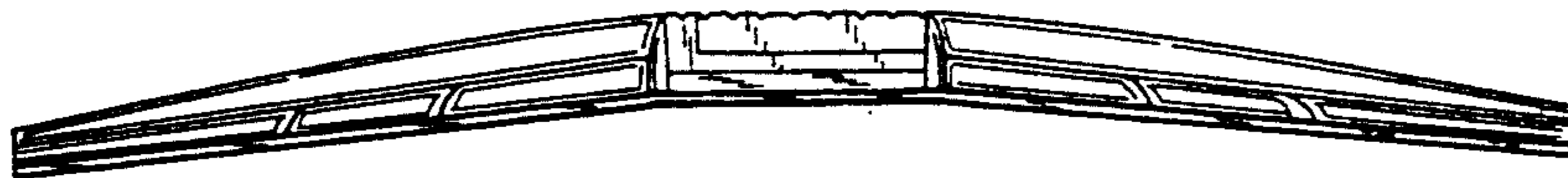

FIG. 2



FIG. 3

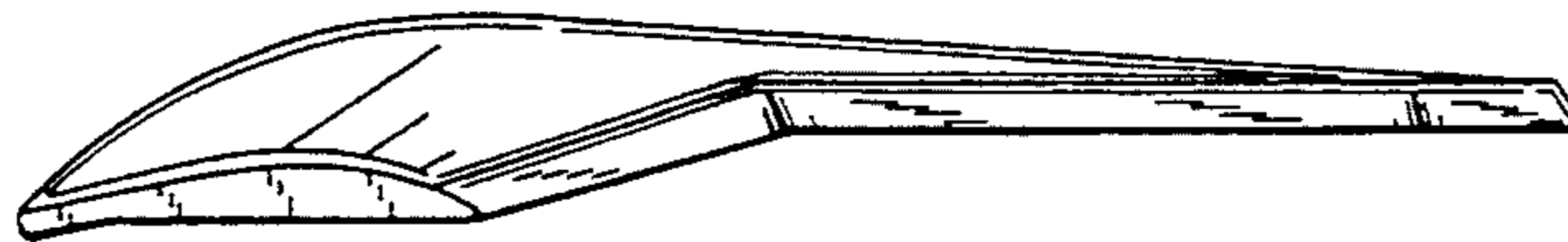

FIG. 4



FIG. 5