



US00D350920S

United States Patent [19]

Tsukui et al.

[11] Patent Number: **Des. 350,920**

[45] Date of Patent: **** Sep. 27, 1994**

[54] **MOTORCYCLE**

[75] Inventors: **Hiroaki Tsukui, Tokyo; Tetsuya Nakazawa, Saitama, both of Japan**

[73] Assignee: **Honda Giken Kogyo Kabushiki Kaisha, Tokyo, Japan**

[**] Term: **14 Years**

[21] Appl. No.: **10,132**

[22] Filed: **Jun. 30, 1993**

[30] **Foreign Application Priority Data**

Feb. 8, 1993 [JP] Japan 5-03056

[52] U.S. Cl. **D12/110**

[58] Field of Search 180/219; D12/110

[56] **References Cited**

U.S. PATENT DOCUMENTS

D. 275,469 9/1984 Morioka et al. D12/110

D. 299,446	1/1989	Kohuma et al.	D12/110
D. 299,447	1/1989	Sakuma et al.	D12/110
D. 332,588	1/1992	Kohama et al.	D12/110
D. 333,641	2/1993	Sakayuchi et al.	D12/110
4,776,422	10/1988	Sakumo	180/219

Primary Examiner—Wallace R. Burke

Assistant Examiner—M. Brown

[57] **CLAIM**

The ornamental design for a motorcycle, as shown and described.

DESCRIPTION

FIG. 1 is a perspective view of a motorcycle showing our new design;

FIG. 2 is a right side elevational view thereof;

FIG. 3 is a left side elevational view thereof;

FIG. 4 is a top plan view thereof;

FIG. 5 is a front elevational view thereof; and,

FIG. 6 is a rear elevational view thereof.

The bottom is substantially flat and not ornamental.

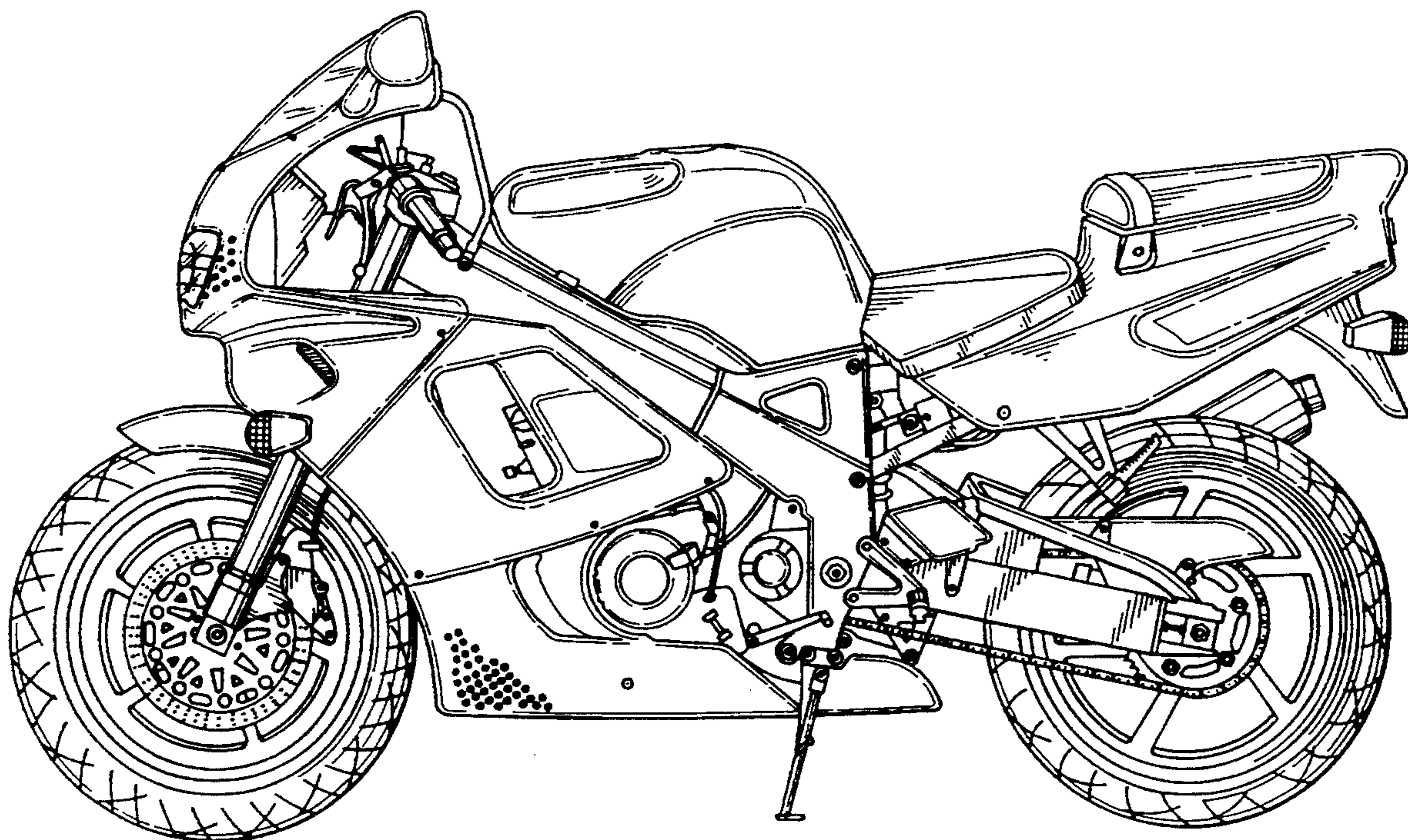

FIG. 1

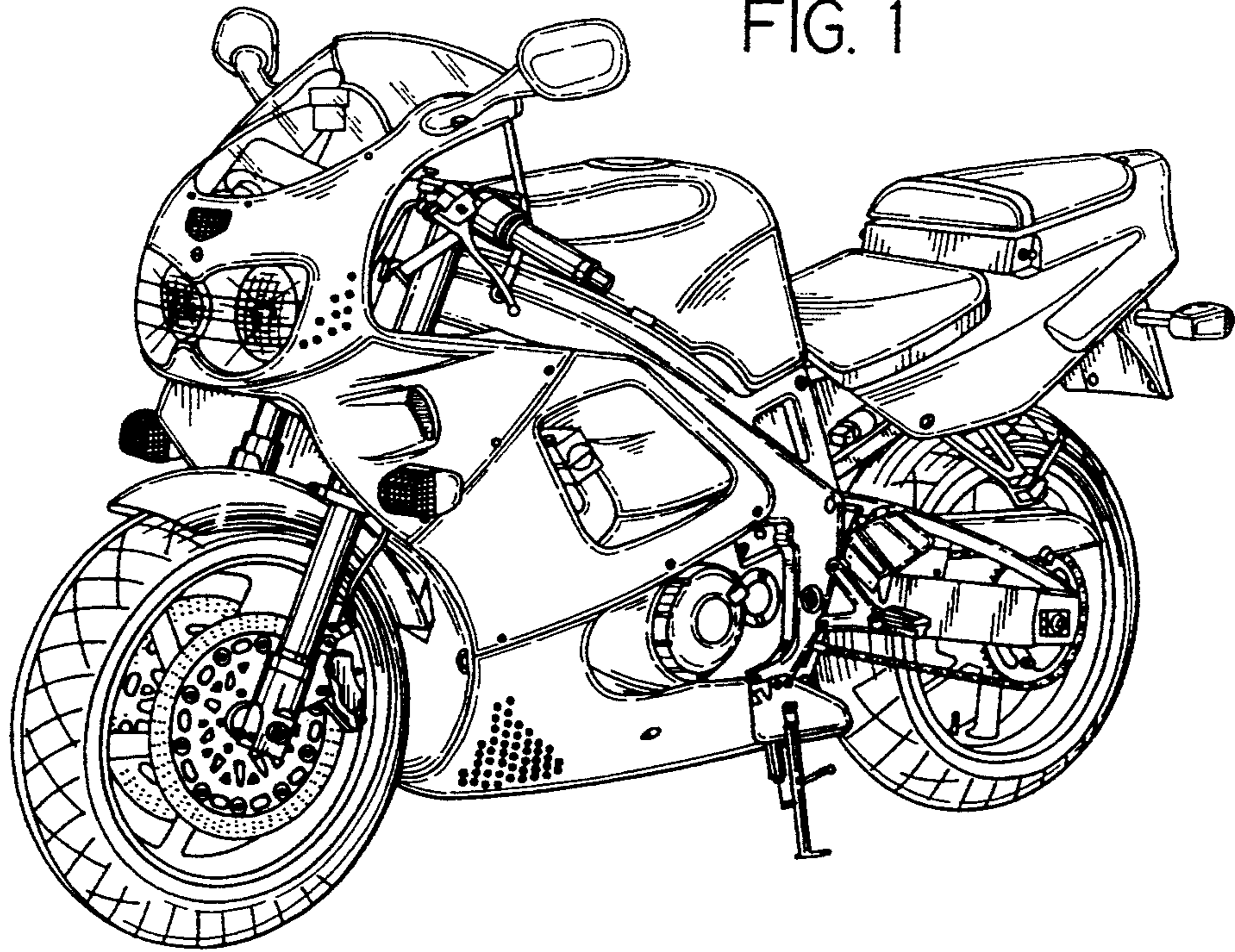

FIG. 2

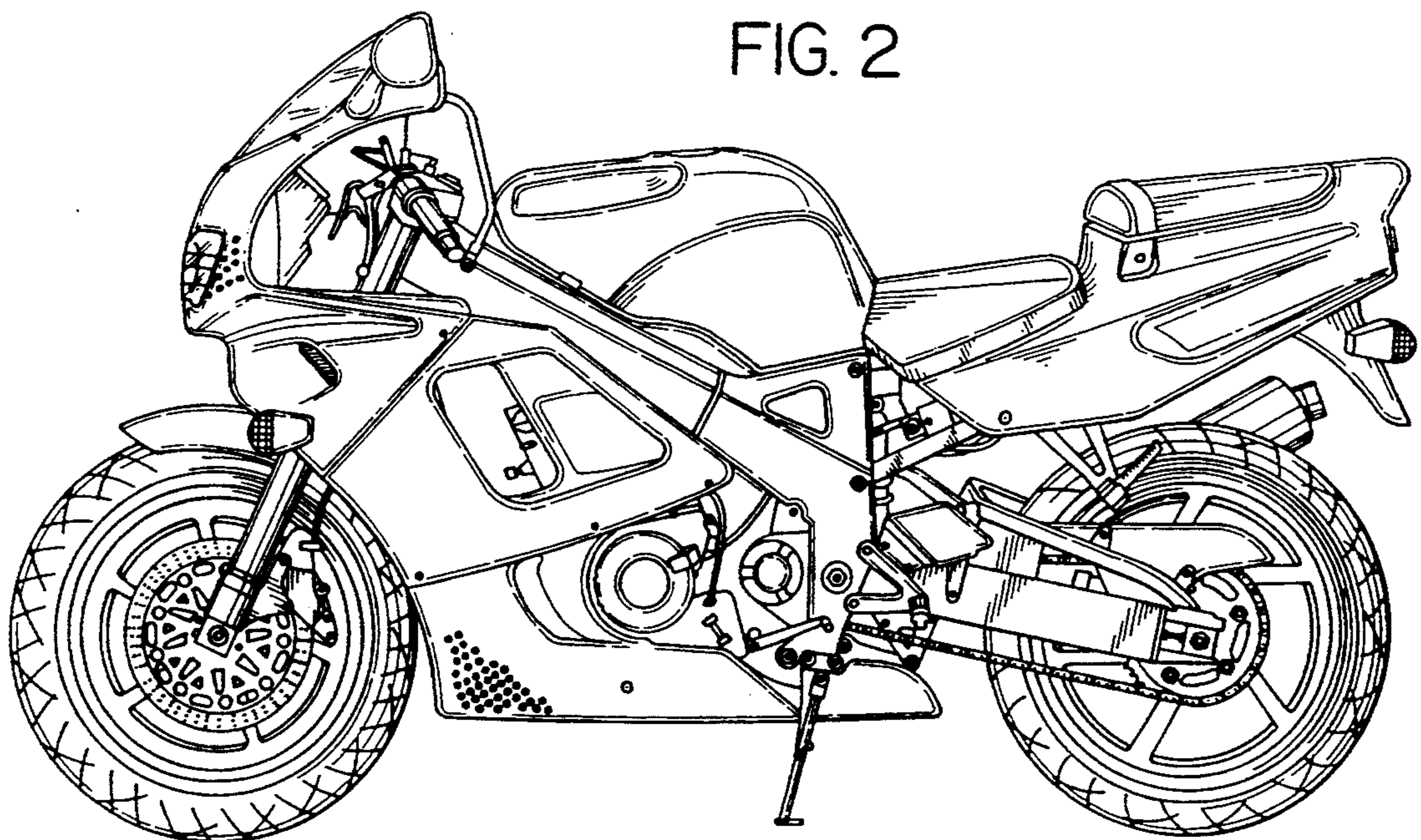

FIG. 3

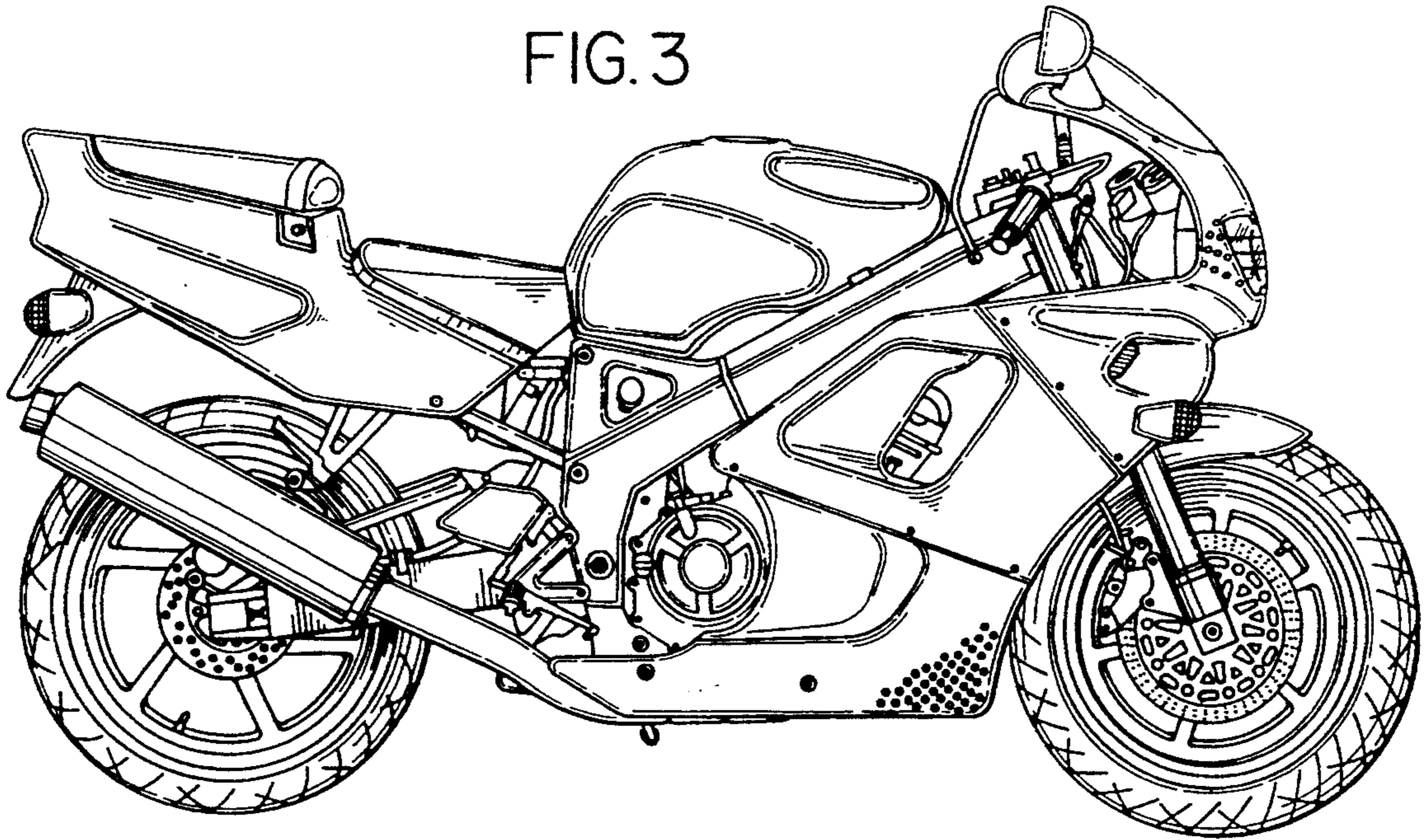

FIG. 4

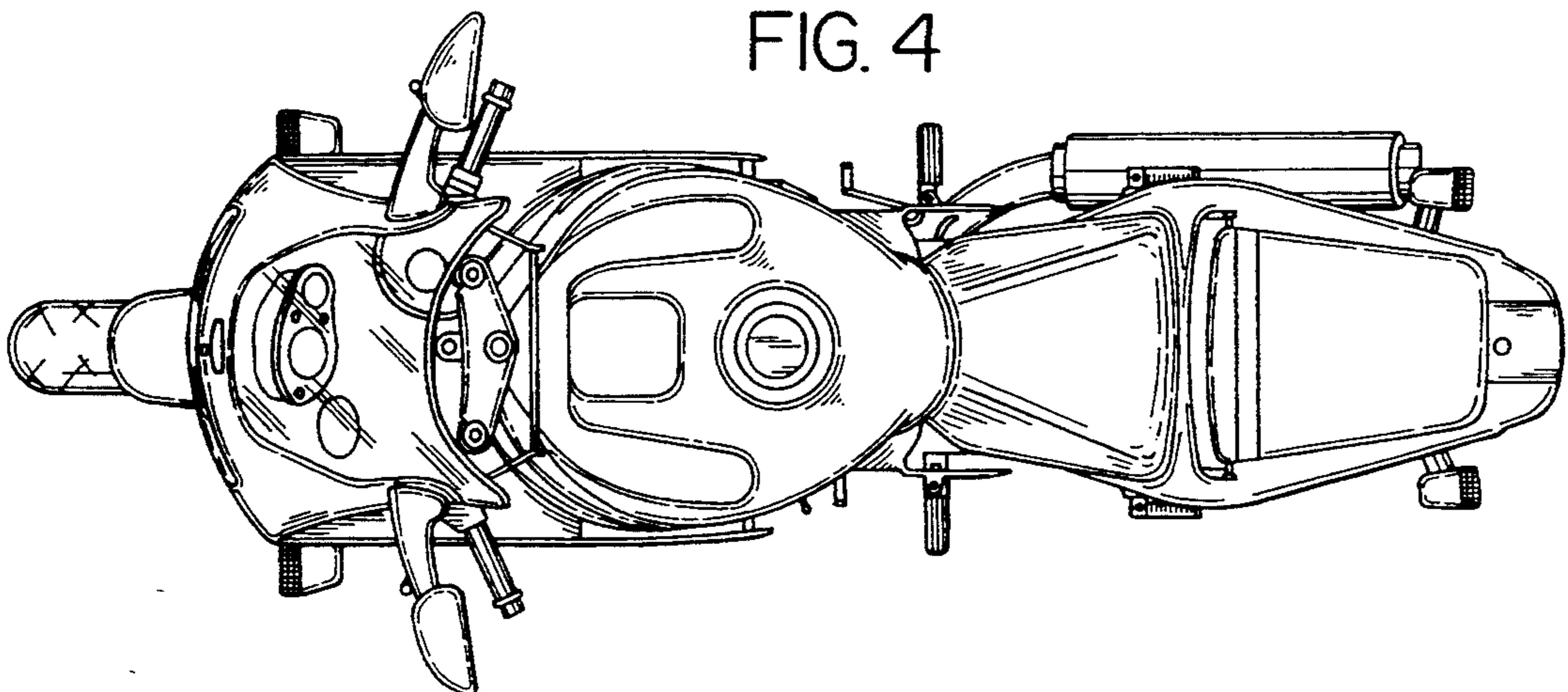

FIG. 5

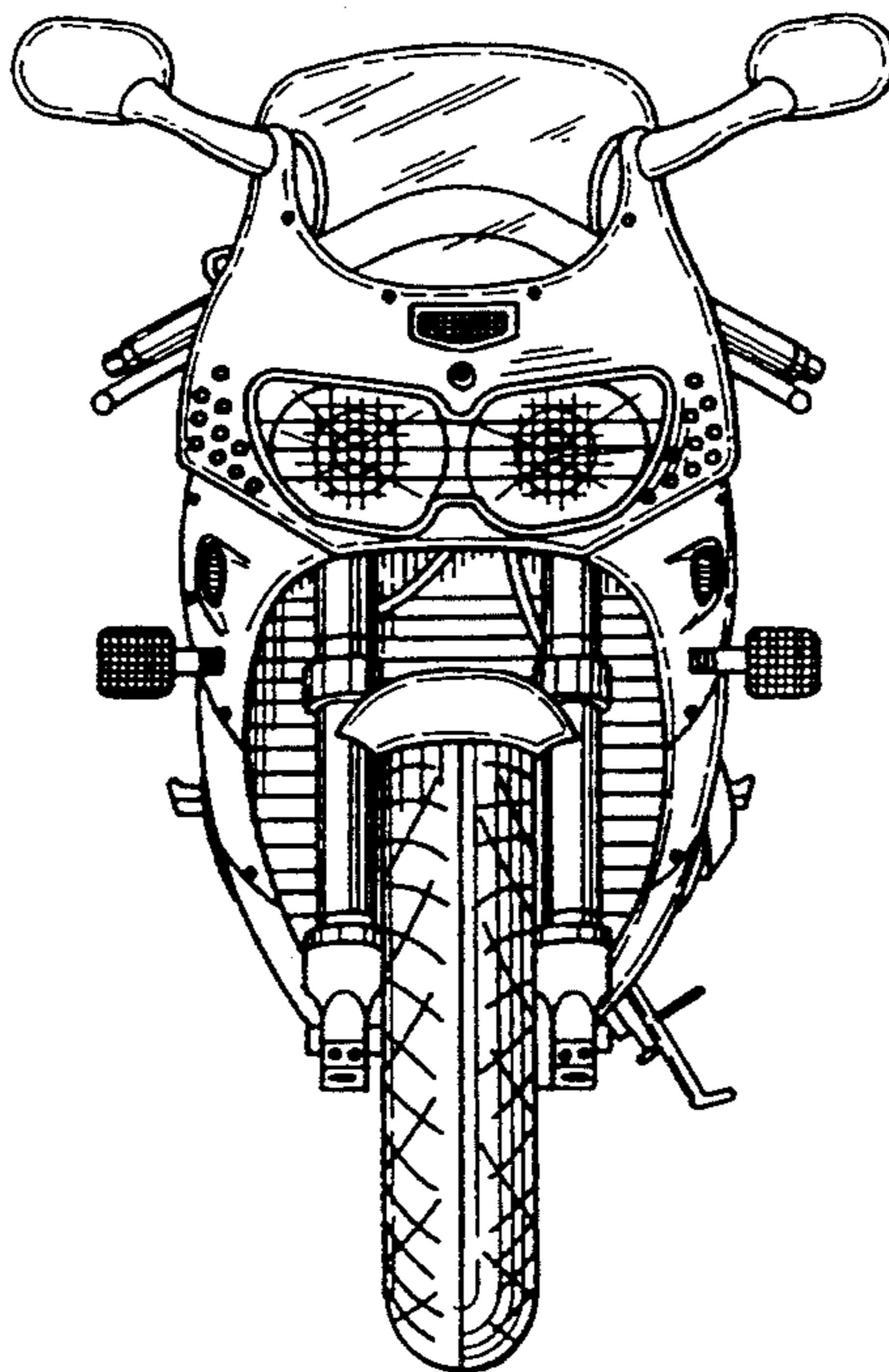

FIG. 6

