



US00D350919S

United States Patent [19]

[11] Patent Number: **Des. 350,919**

Kishi et al.

[45] Date of Patent: **** Sep. 27, 1994**

[54] **MOTORCYCLE**

[75] Inventors: **Toshiaki Kishi; Takahiro Asakawa,**
both of Tokyo, Japan

[73] Assignee: **Honda Giken Kogyo Kabushiki**
Kaisha, Tokyo, Japan

[**] Term: **14 Years**

[21] Appl. No.: **3,168**

[22] Filed: **Dec. 30, 1992**

[30] **Foreign Application Priority Data**

Sep. 22, 1992 [JP] Japan 4-27778

[52] U.S. Cl. **D12/110**

[58] Field of Search 280/219; D12/110

[56] **References Cited**

U.S. PATENT DOCUMENTS

D. 321,849 11/1991 Abe et al. D12/110

D. 332,588 1/1993 Kohama et al. D12/110
D. 333,641 3/1993 Sakaguchi et al. D12/110
D. 336,450 6/1993 Tsukui et al. D12/110

Primary Examiner—Wallace R. Burke

Assistant Examiner—M. N. Brown

[57] **CLAIM**

The ornamental design for a motorcycle, as shown and described.

DESCRIPTION

FIG. 1 is a left perspective view of a motorcycle showing my new design;

FIG. 2 is a right perspective view thereof;

FIG. 3 is a left side elevational view thereof;

FIG. 4 is a right side elevational view thereof;

FIG. 5 is a front elevational view thereof;

FIG. 6 is a rear elevational view thereof;

FIG. 7 is a top plan view thereof; and,

FIG. 8 is a bottom plan view thereof.

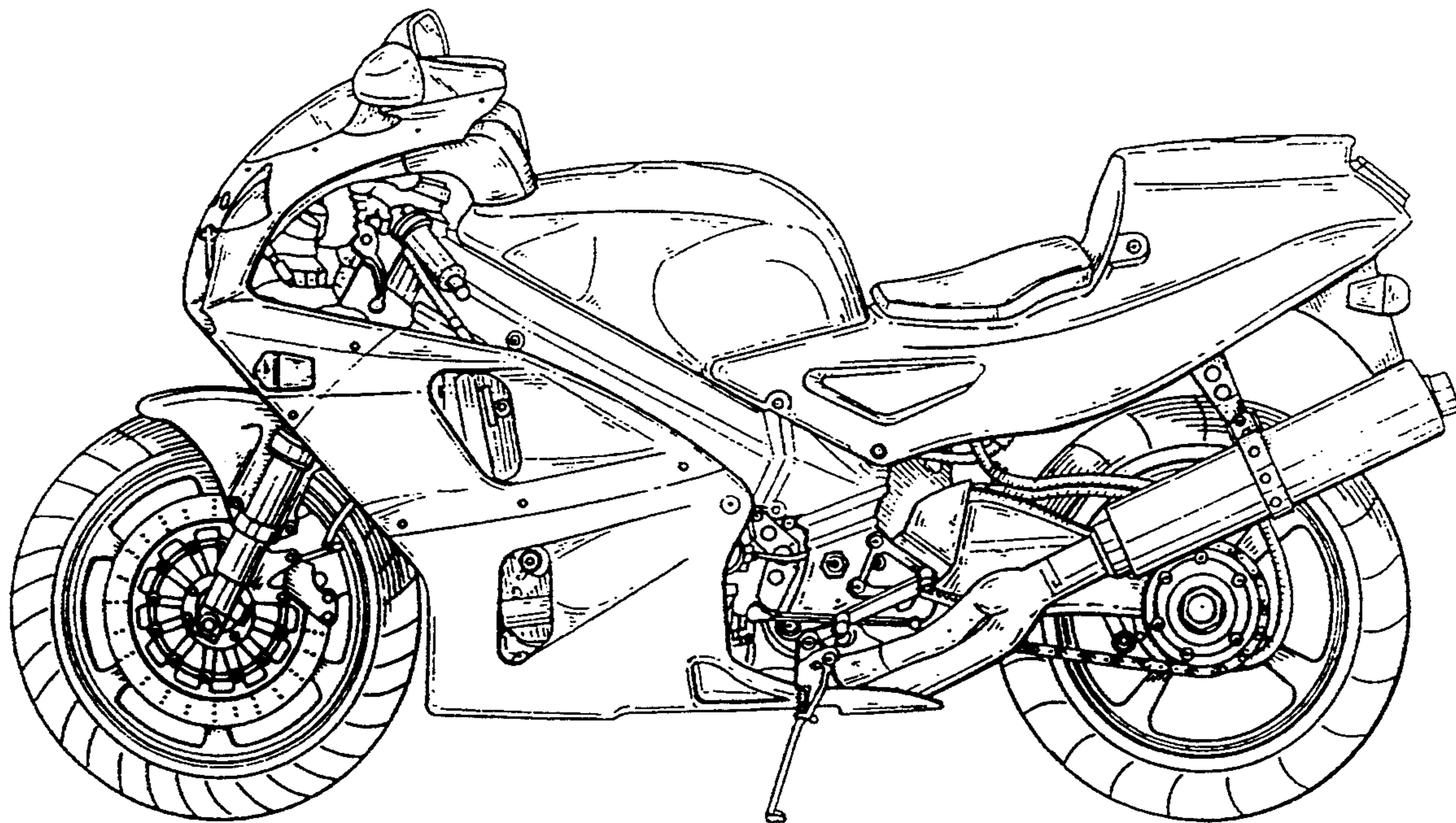

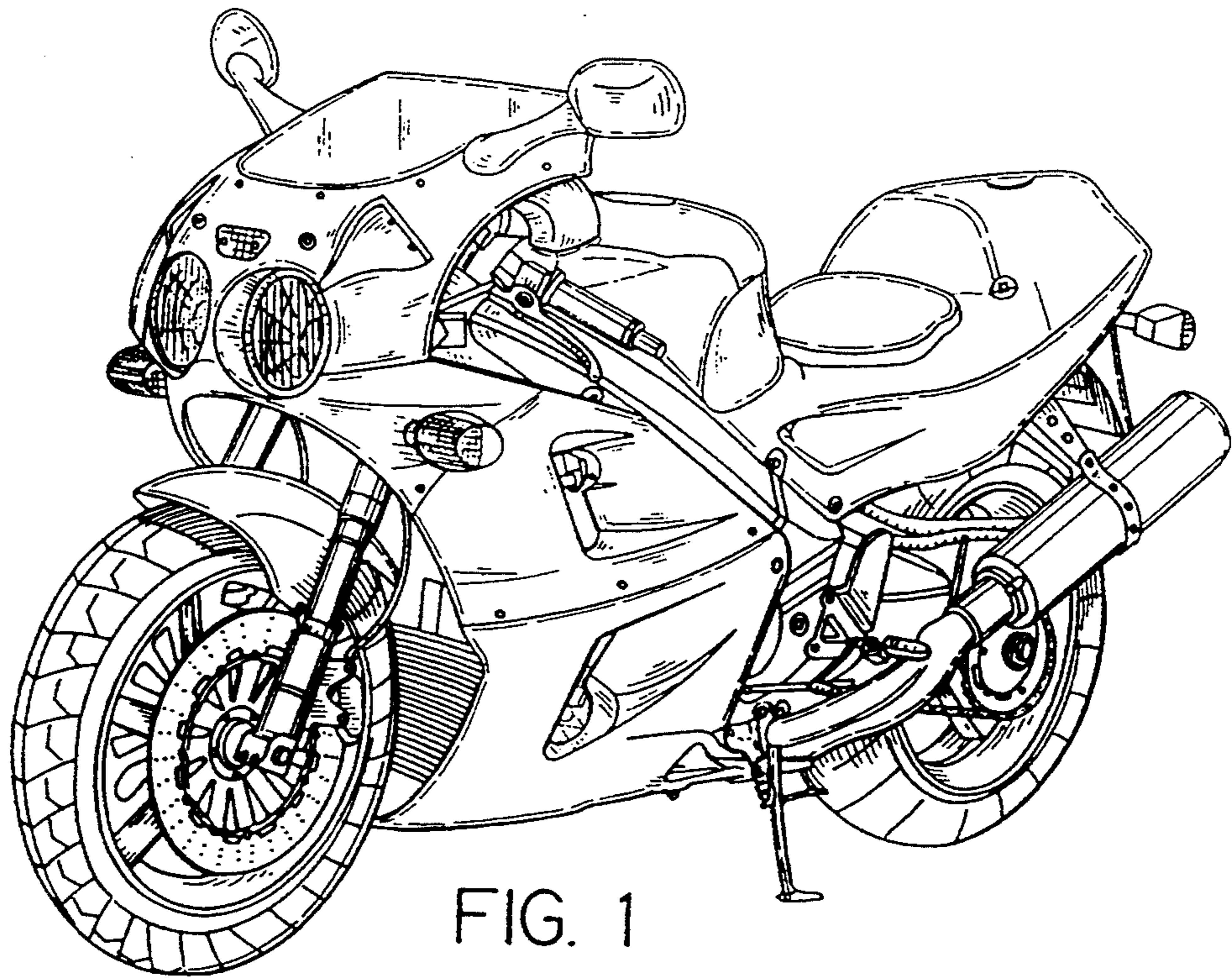

FIG. 1

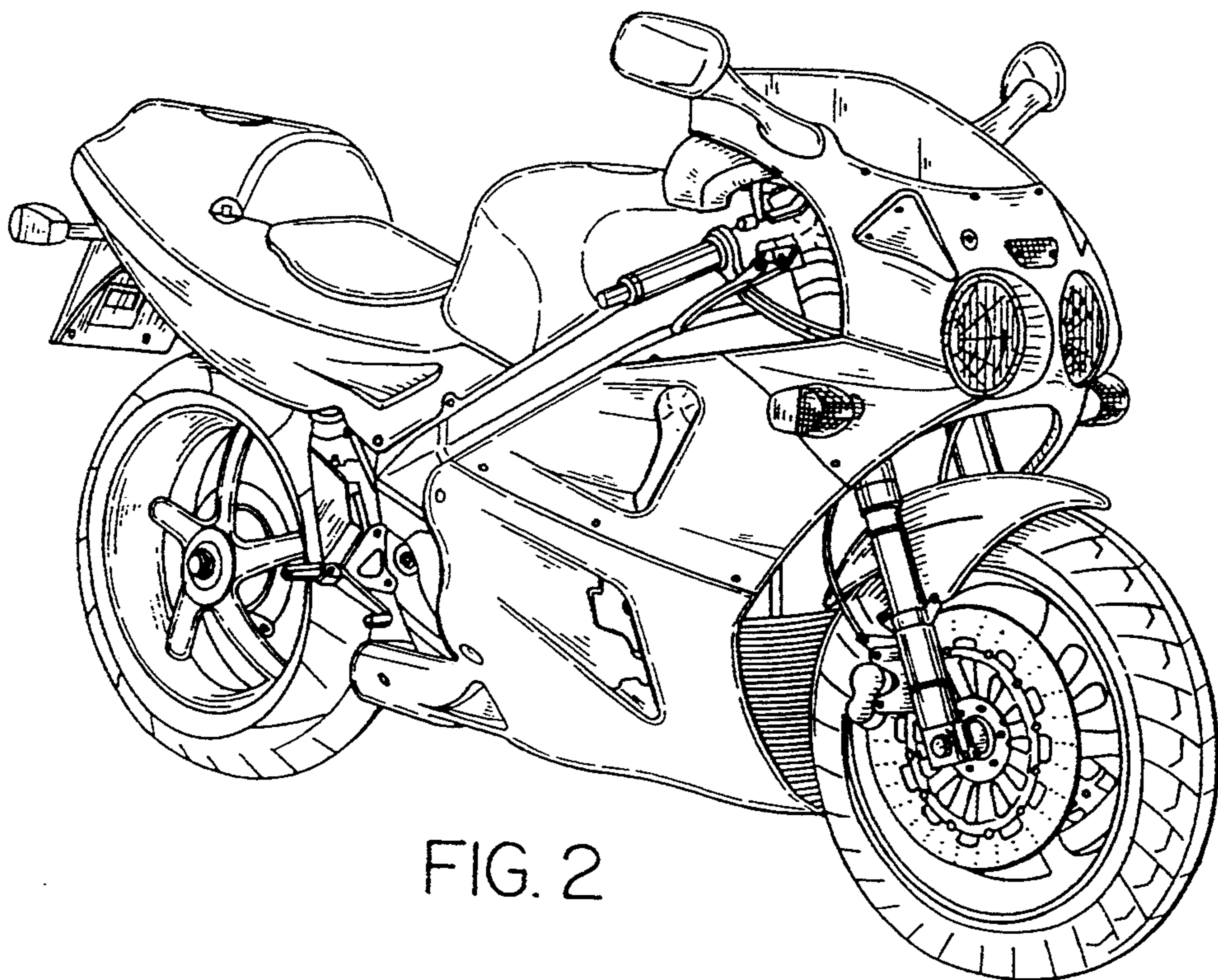

FIG. 2

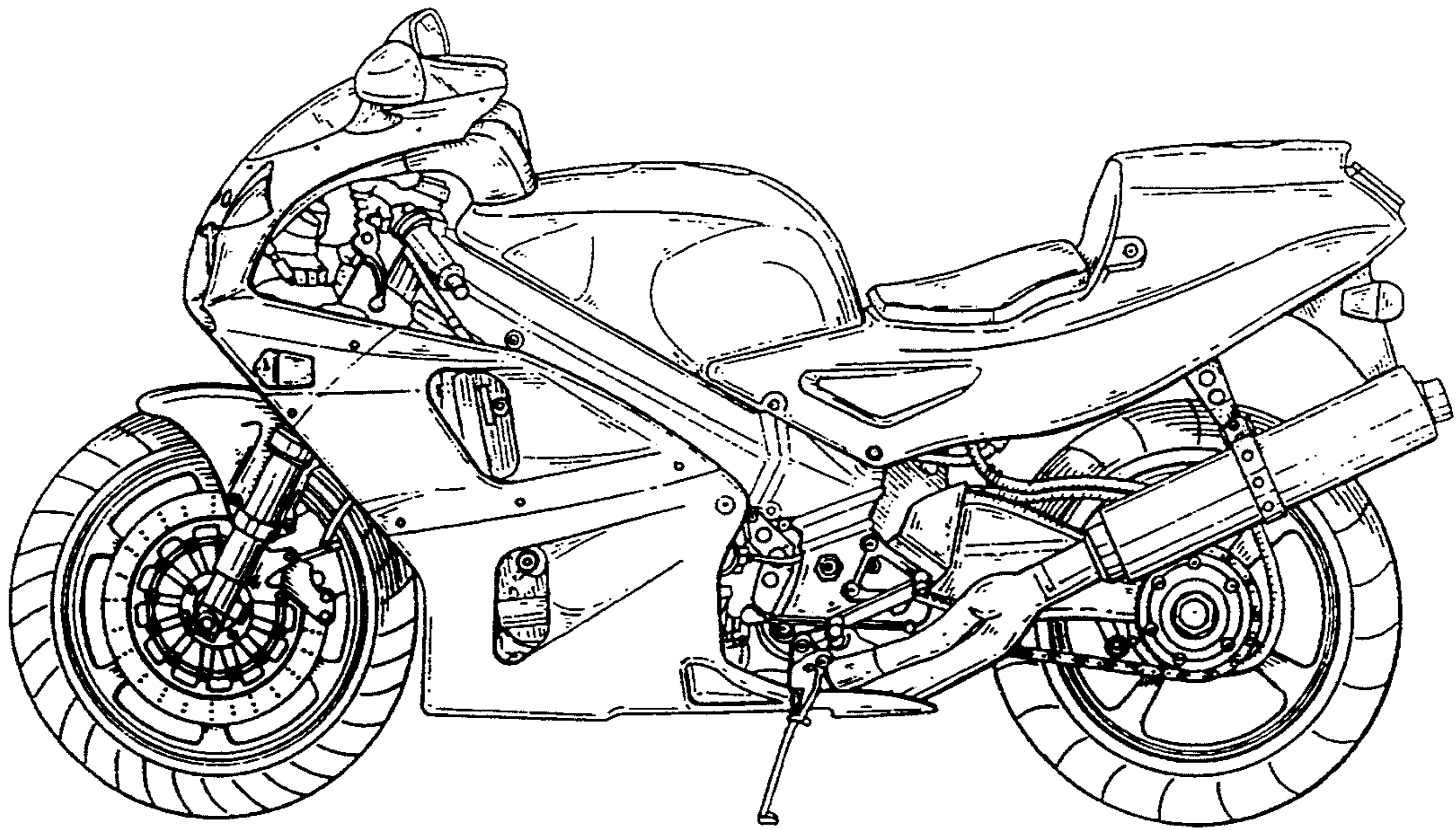

FIG. 3

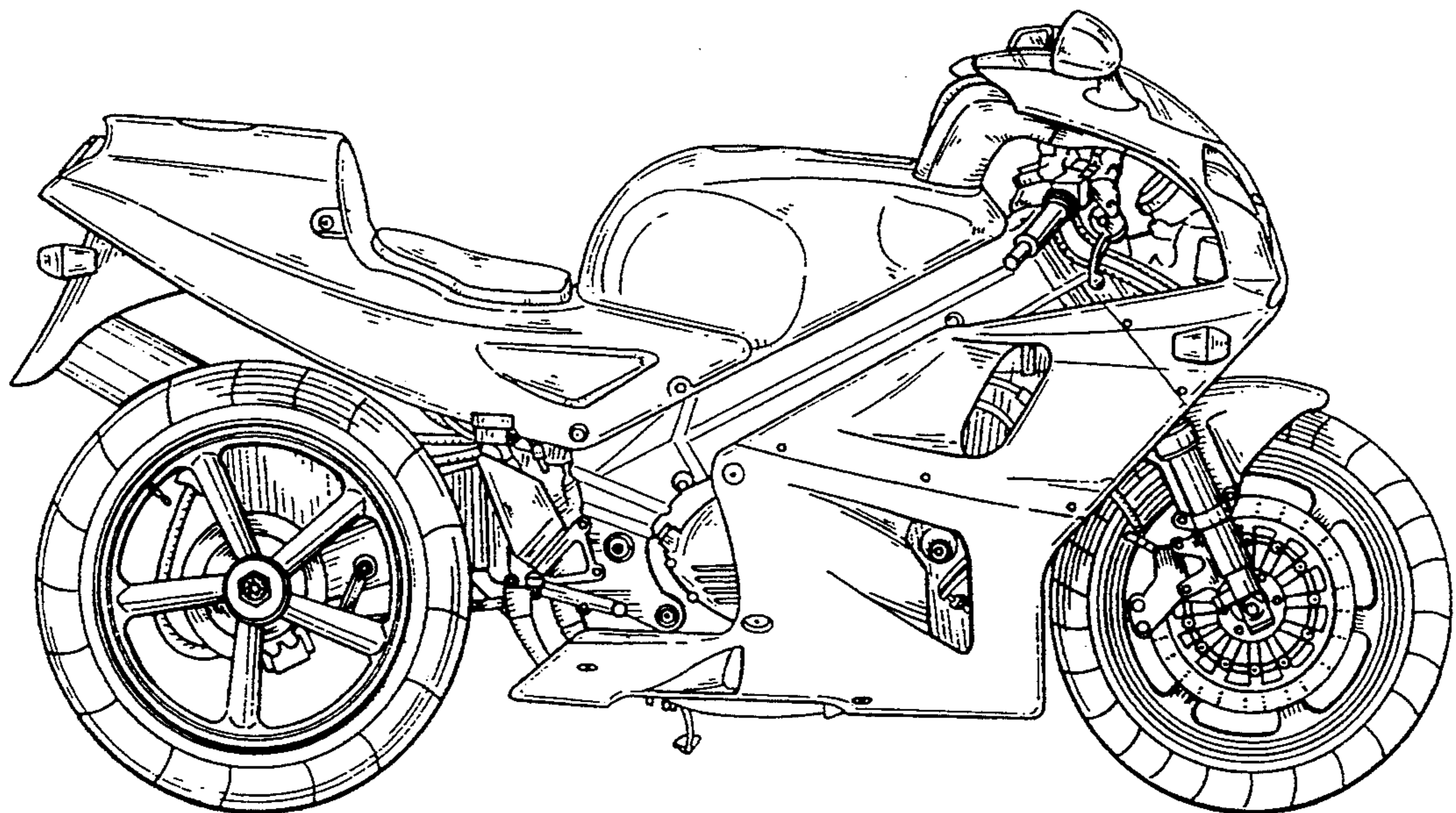

FIG. 4

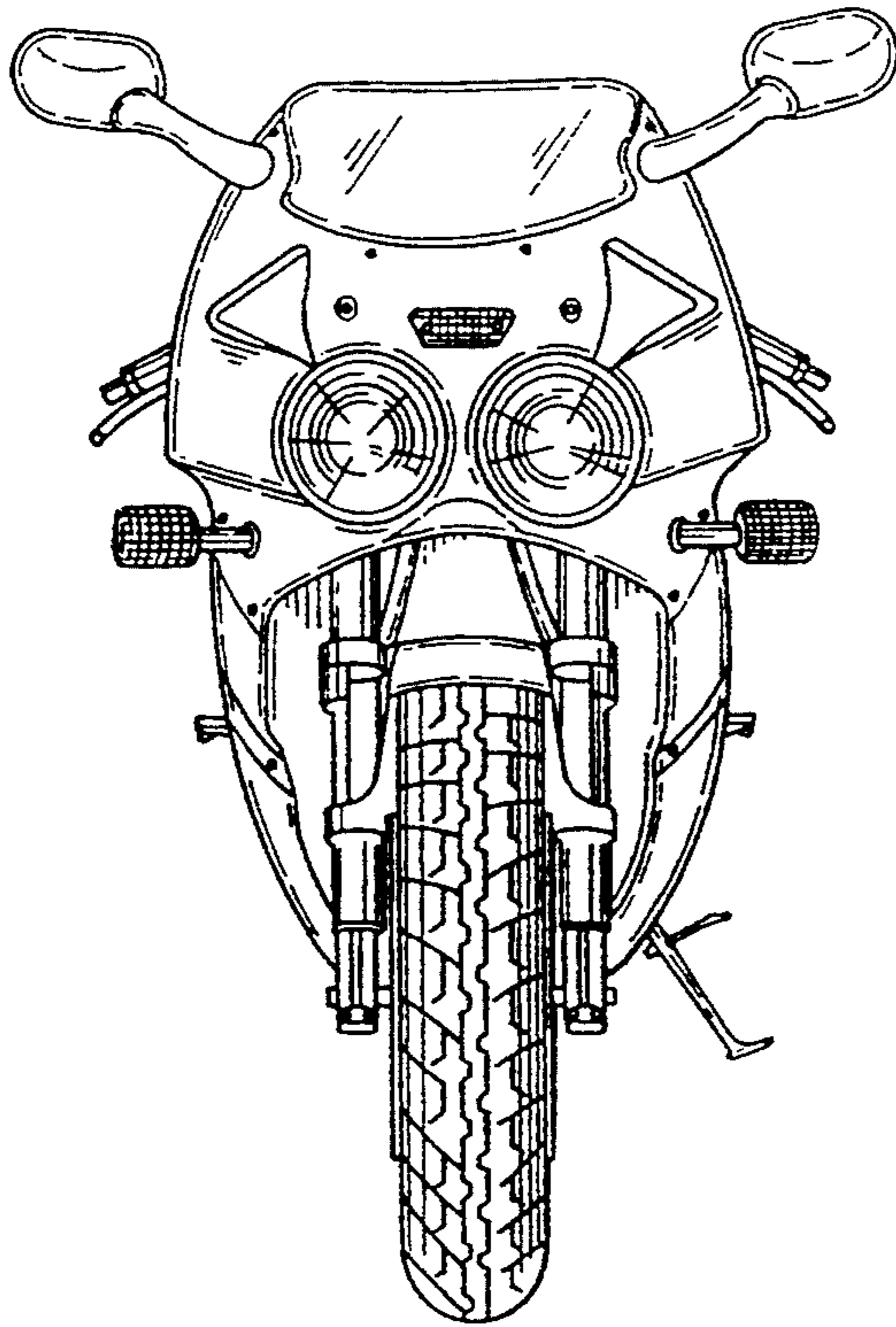

FIG. 5

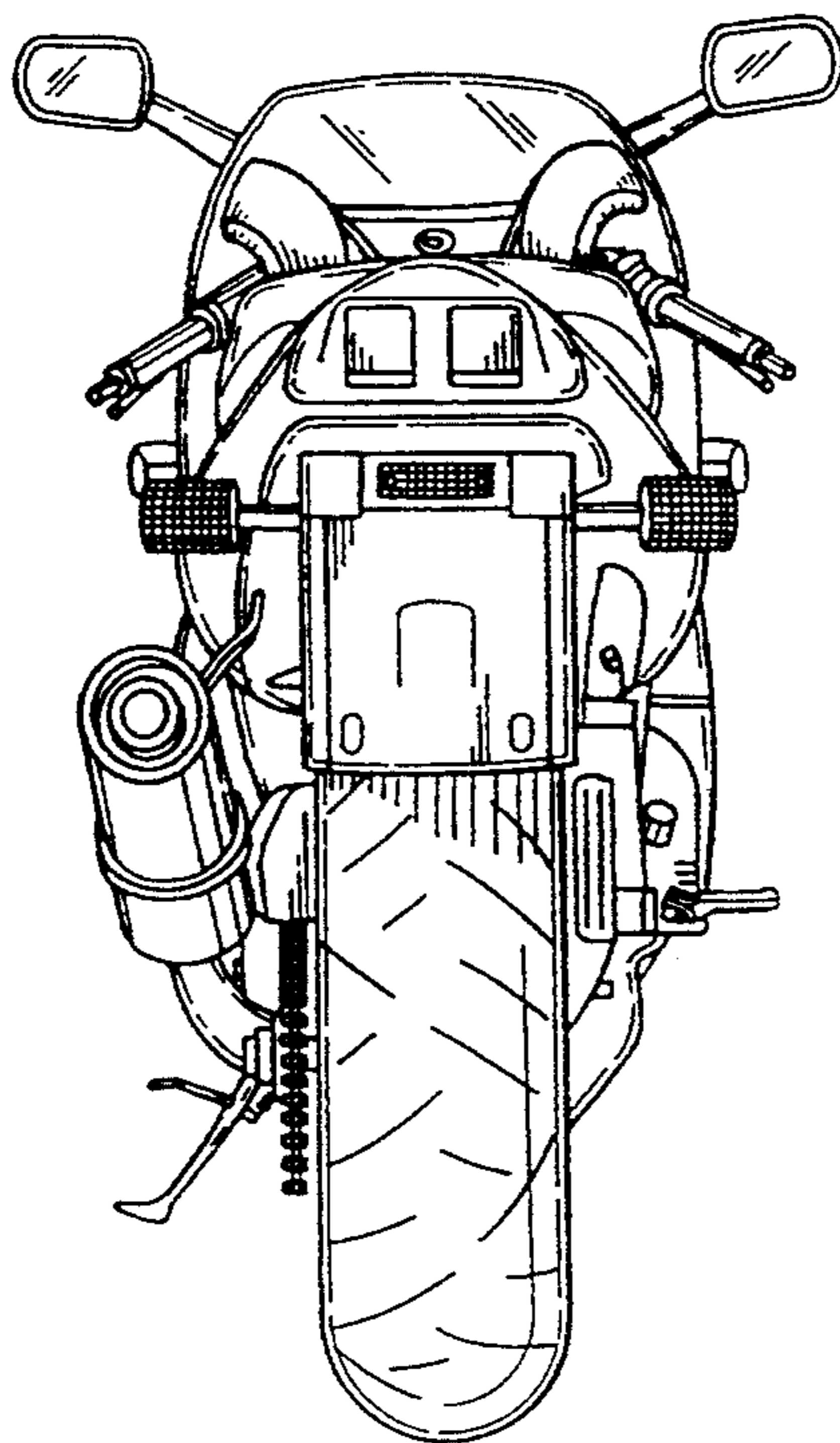

FIG. 6

FIG. 7

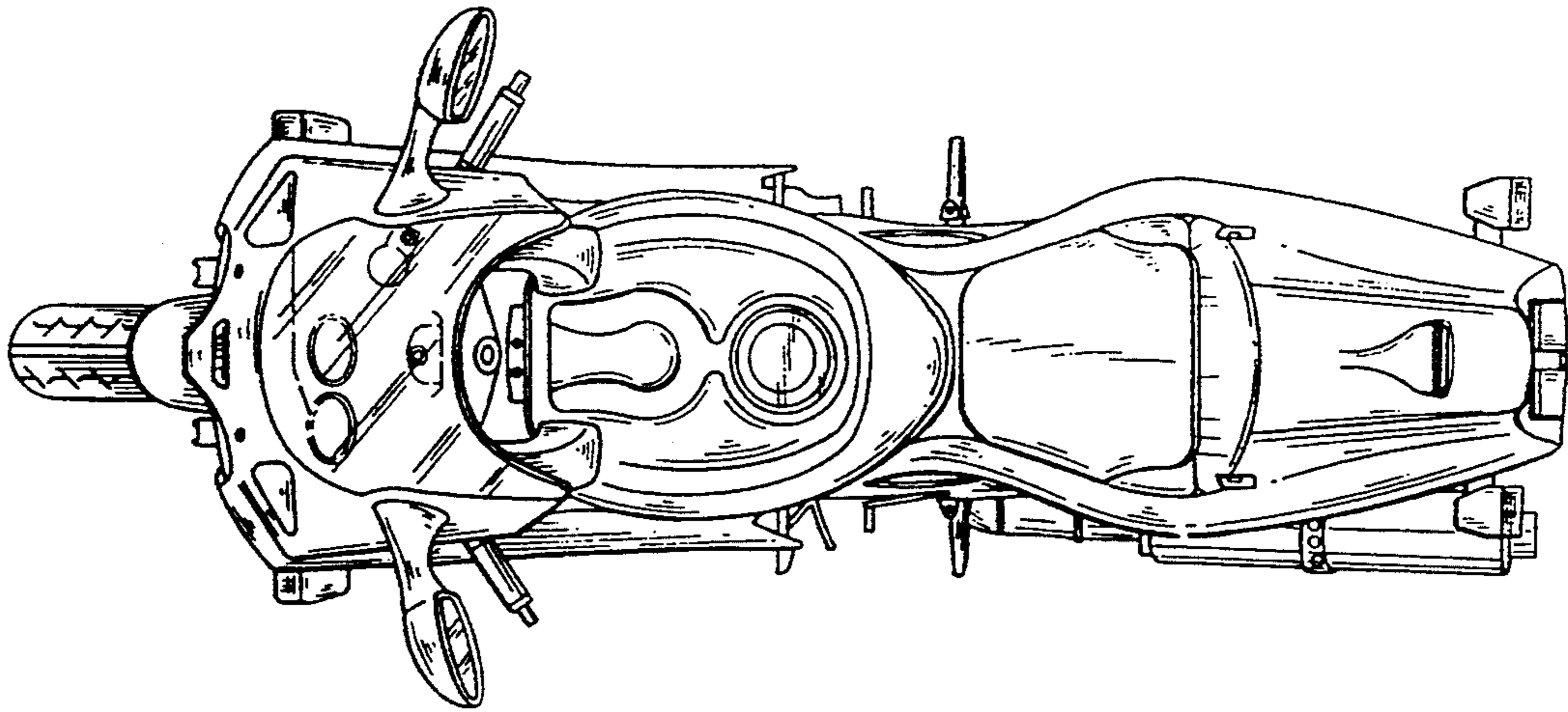

FIG. 8

