



US00D350918S

United States Patent [19]

[11] Patent Number: **Des. 350,918**

Kohama et al.

[45] Date of Patent: **** Sep. 27, 1994**

[54] **MOTORCYCLE**

[56] **References Cited**

[75] Inventors: **Mitsuyoshi Kohama; Yoshiaki Muta,**
both of Saitama; **Yuuji Watanuki,**
Tokyo, all of Japan

U.S. PATENT DOCUMENTS

D. 321,849 11/1991 Abe et al. D12/110
D. 332,588 1/1993 Kohama et al. D12/110
D. 333,641 3/1993 Sakaguchi et al. D12/110
D. 336,450 6/1993 Tsukiu et al. D12/110

[73] Assignee: **Honda Giken Kogyo Kabushiki**
Kaisha, Tokyo, Japan

Primary Examiner—Wallace R. Burke
Assistant Examiner—M. N. Brown

[**] Term: **14 Years**

[57] **CLAIM**

The ornamental design for a motorcycle, as shown and described.

[21] Appl. No.: **9,596**

DESCRIPTION

[22] Filed: **Jun. 18, 1993**

FIG. 1 is a perspective view of a motorcycle showing our new design;
FIG. 2 is a right side elevational view thereof;
FIG. 3 is a left side elevational view thereof;
FIG. 4 is a top plan view thereof;
FIG. 5 is a front elevational view thereof; and,
FIG. 6 is a rear elevational view thereof.
The bottom is substantially flat and not ornamental.

[30] Foreign Application Priority Data

Dec. 18, 1992 [JP] Japan 4-37092
[52] U.S. Cl. **D12/110**
[58] Field of Search 280/219; D12/110

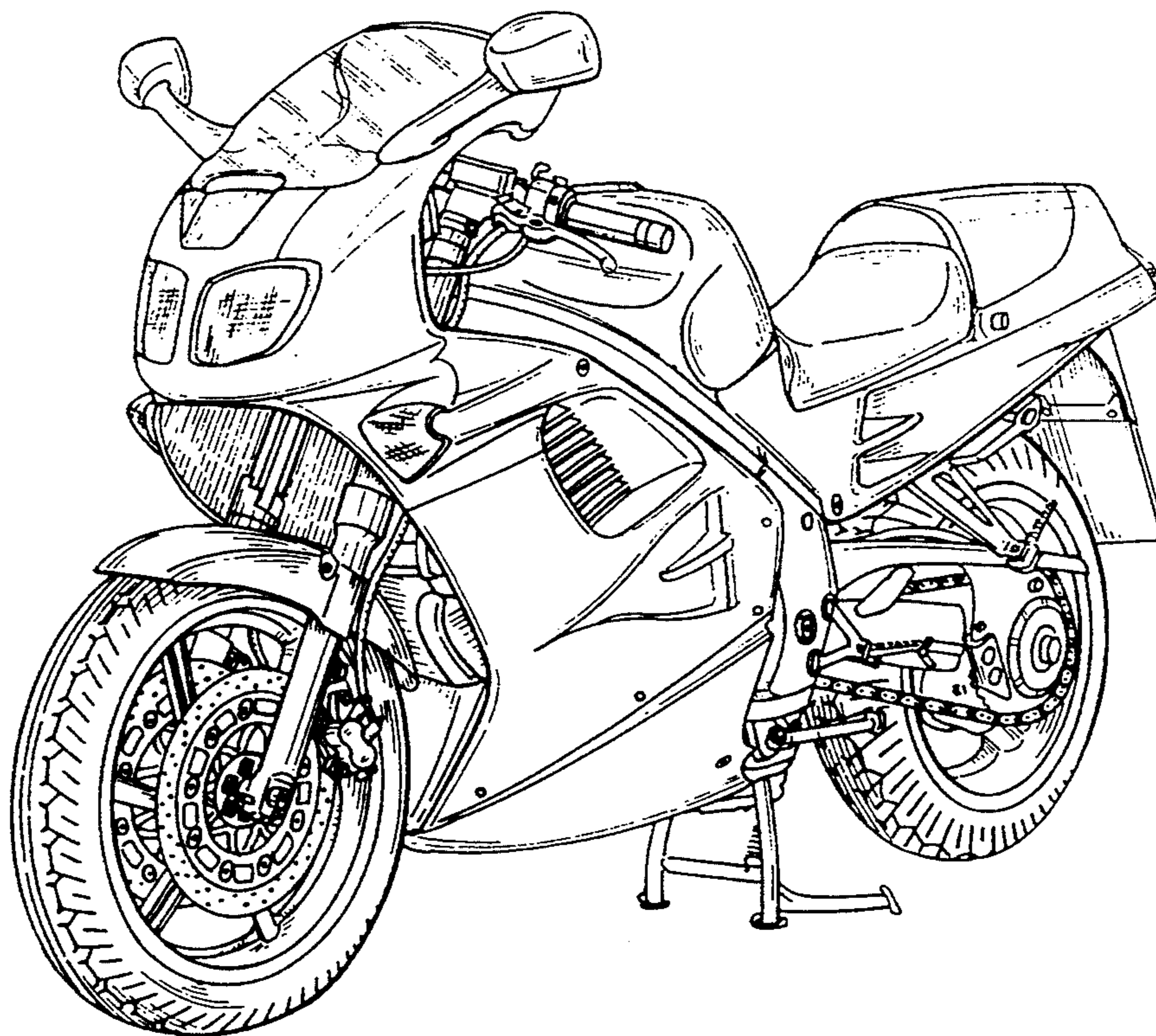

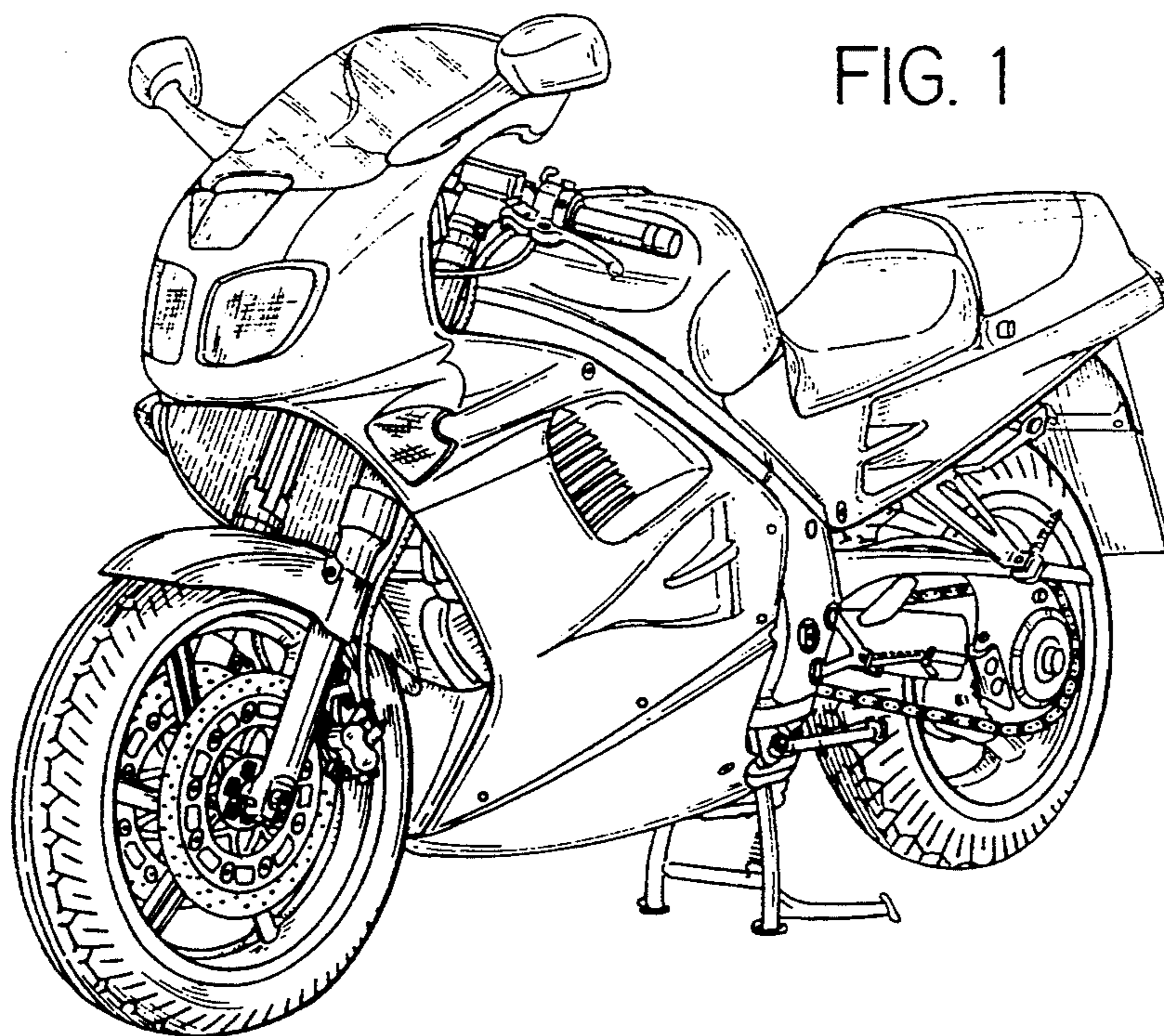

FIG. 1

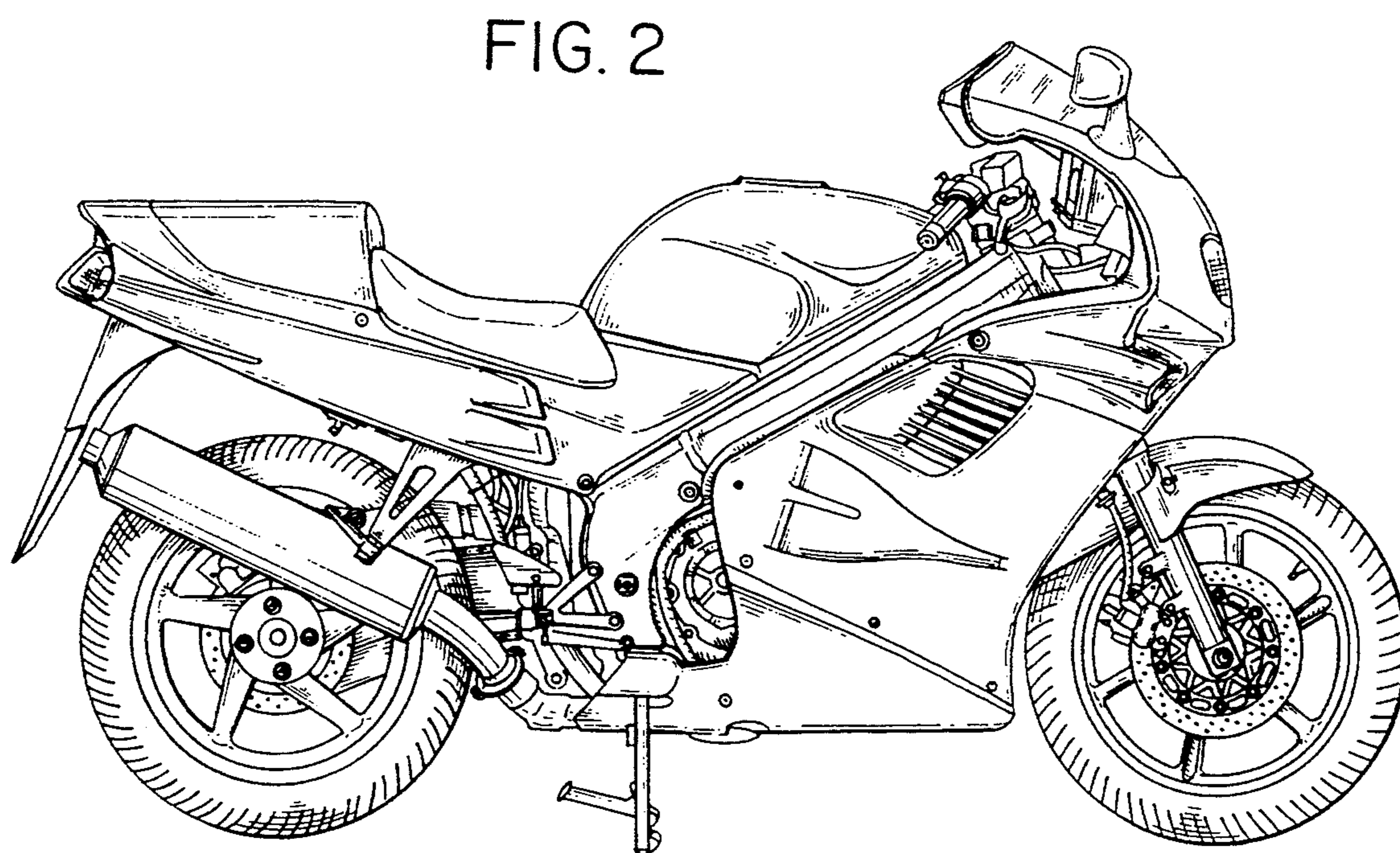

FIG. 2

FIG.3

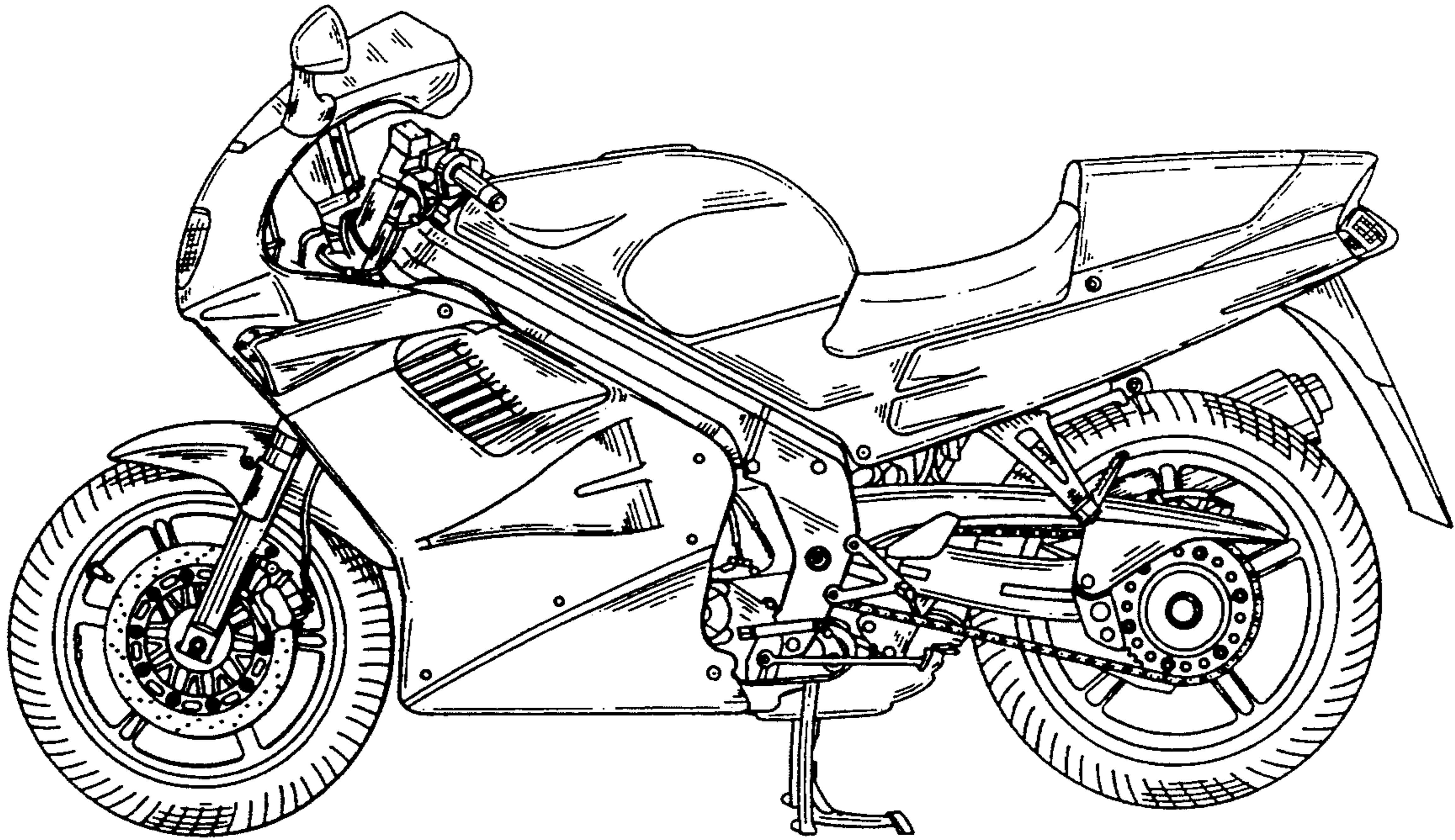

FIG.4

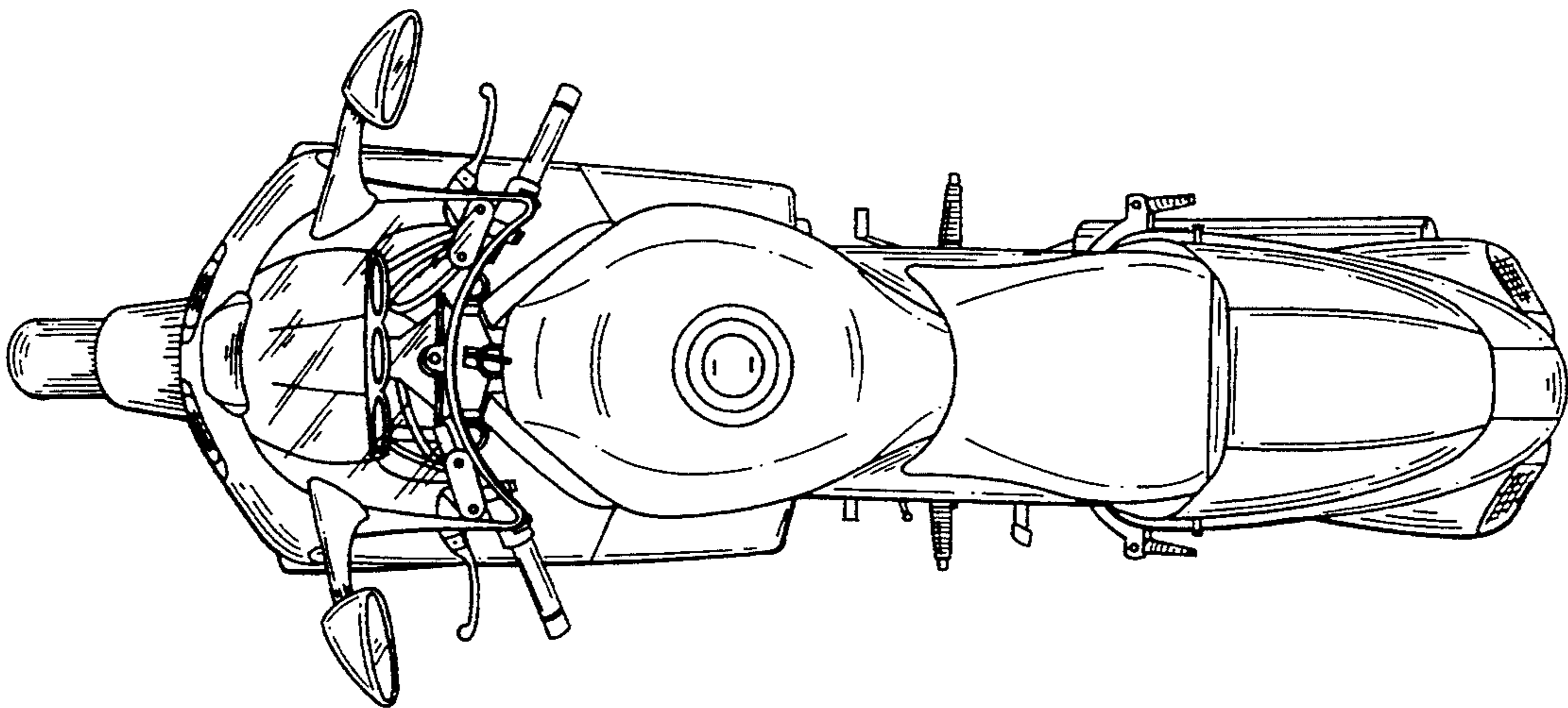

FIG. 5

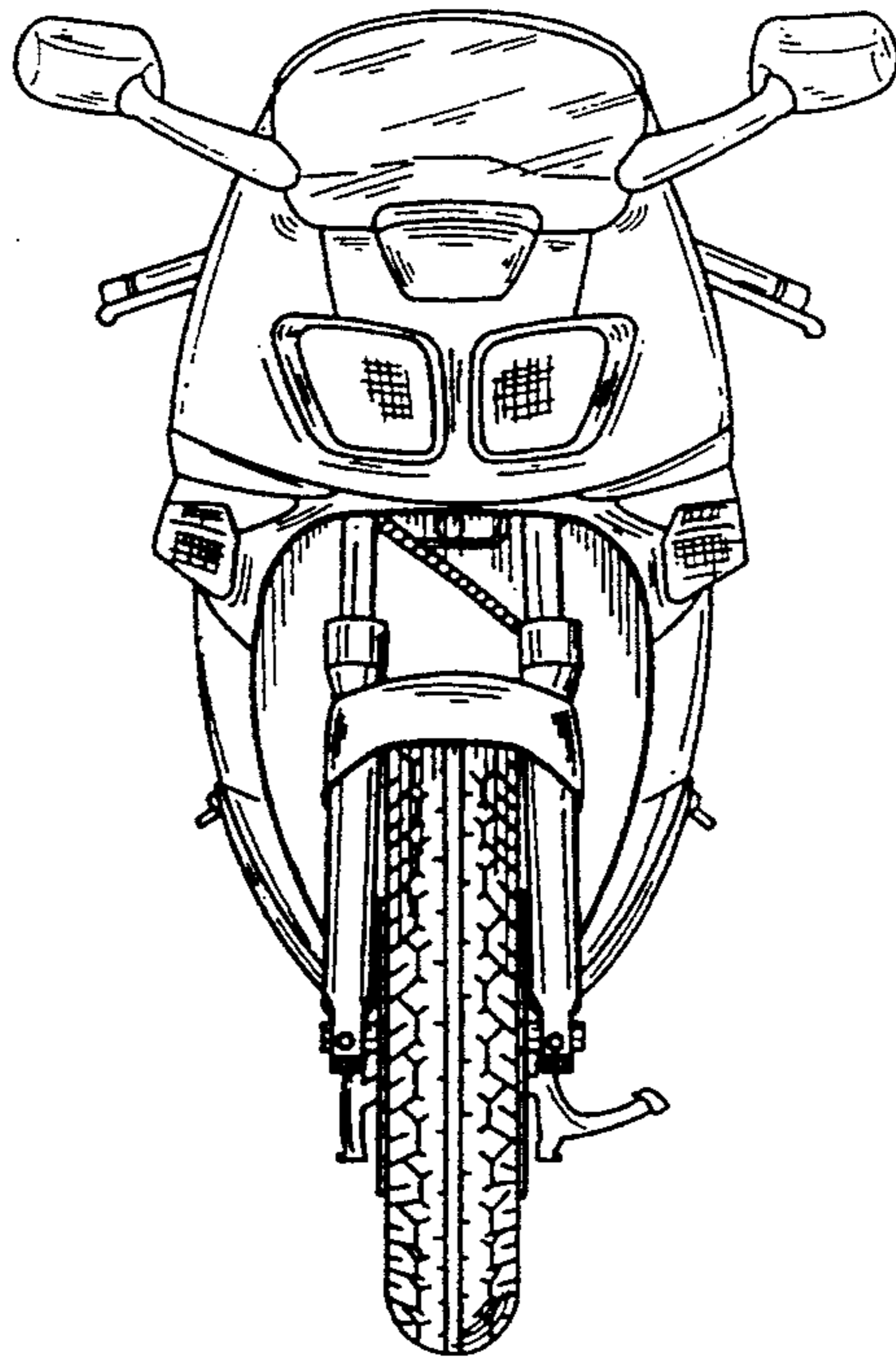

FIG. 6

