



US00D350813S

# United States Patent [19]

[11] Patent Number: **Des. 350,813**

Yarbrough

[45] Date of Patent: **\*\* Sep. 20, 1994**

[54] **BOAT FUEL DELIVERY APPARATUS**

2,956,553	10/1960	Bell	.....	137/563	X
2,970,441	2/1961	Marsh	.....	137/563	X
4,653,532	3/1987	Powers	.....	137/563	

[76] Inventor: **Michael C. Yarbrough**, 205 Timber Creek, Kemp, Tex. 75143

*Primary Examiner*—Stella Reid  
*Assistant Examiner*—Eric M. Watterson  
*Attorney, Agent, or Firm*—Hugh E. Smith

[\*\*] Term: **14 Years**

[21] Appl. No.: **854,058**

[57] **CLAIM**

[22] Filed: **Mar. 19, 1992**

[52] U.S. Cl. .... **D23/259**

The ornamental design for a boat fuel delivery apparatus, as shown and described.

[58] Field of Search ..... 137/567, 563, 566;  
123/179.11; D23/233-237, 259-269; D15/9.2,  
9.1

**DESCRIPTION**

[56] **References Cited**

**U.S. PATENT DOCUMENTS**

759,374	5/1904	Isaacs et al.	.....	137/566	X
993,509	5/1911	Cowles	.....	137/563	X
2,644,195	7/1953	Bennes et al.	.....	137/563	X
2,894,664	7/1959	Mroz	.....	137/563	X

FIG. 1 is a front elevational view of the boat fuel delivery apparatus showing my new design;  
FIG. 2 is a rear elevational view thereof;  
FIG. 3 is a left side elevational view thereof;  
FIG. 4 is a right side elevational view thereof;  
FIG. 5 is a top plan view thereof; and,  
FIG. 6 is a bottom plan view thereof.

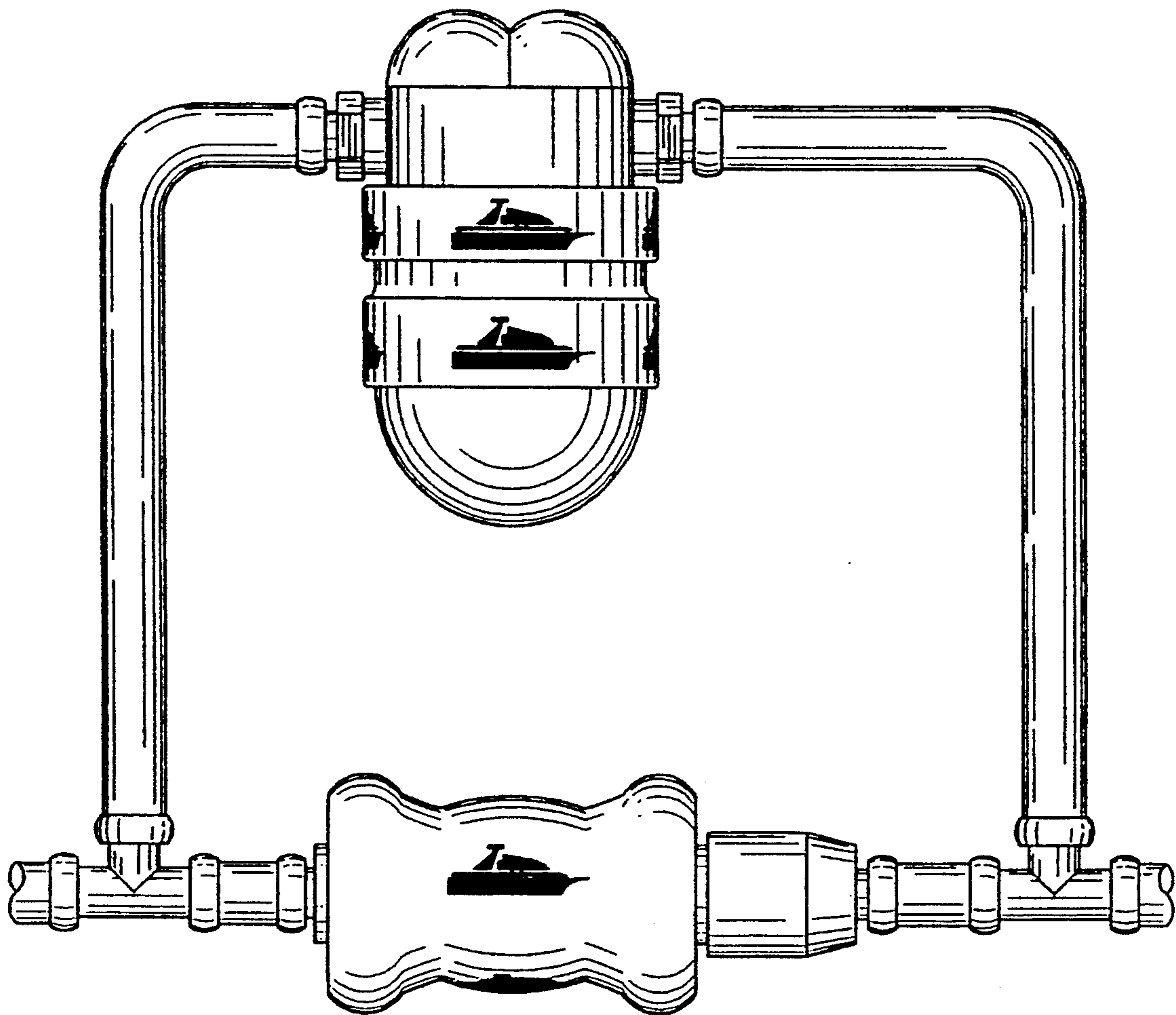

FIG. 1

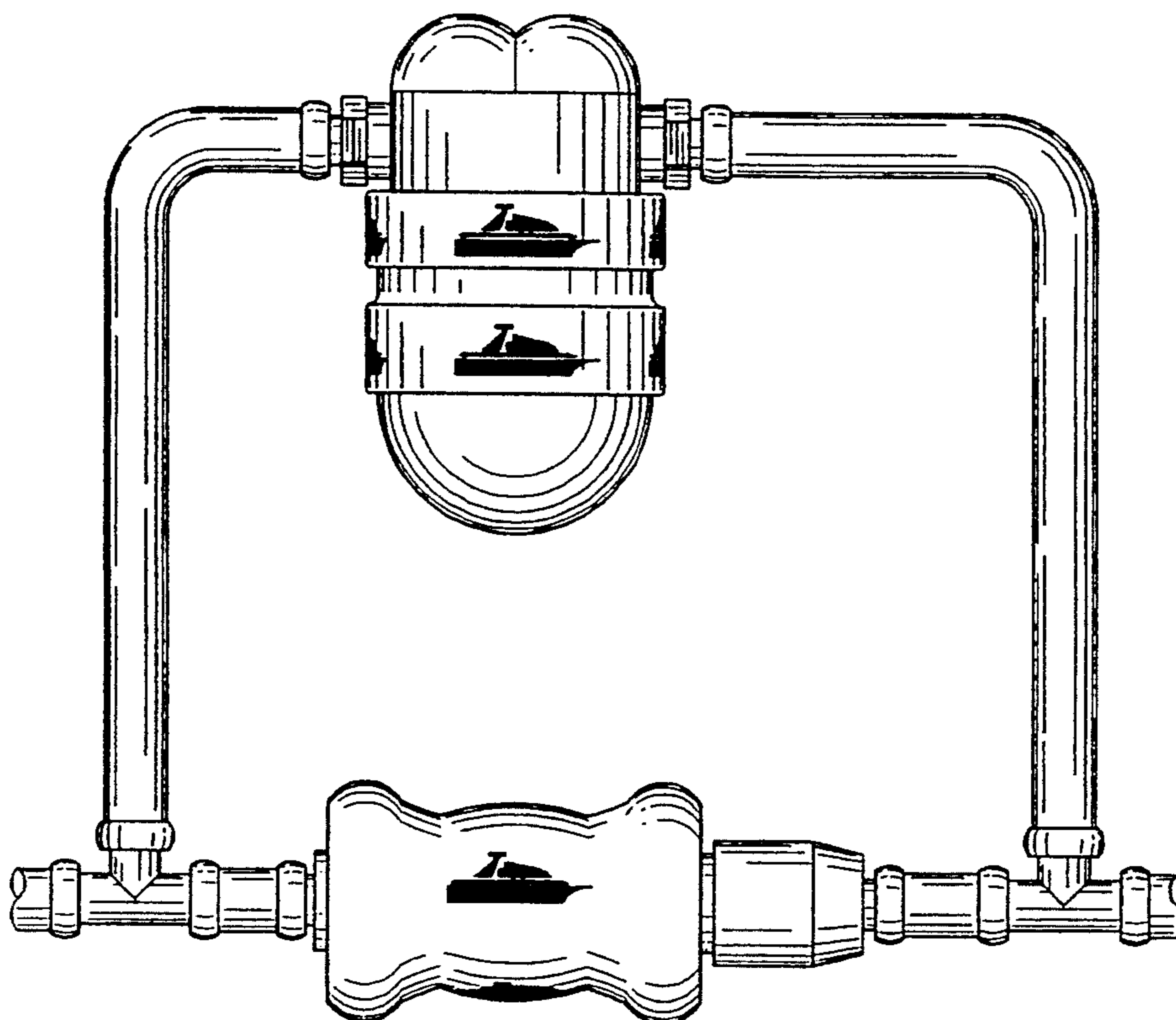

FIG. 2

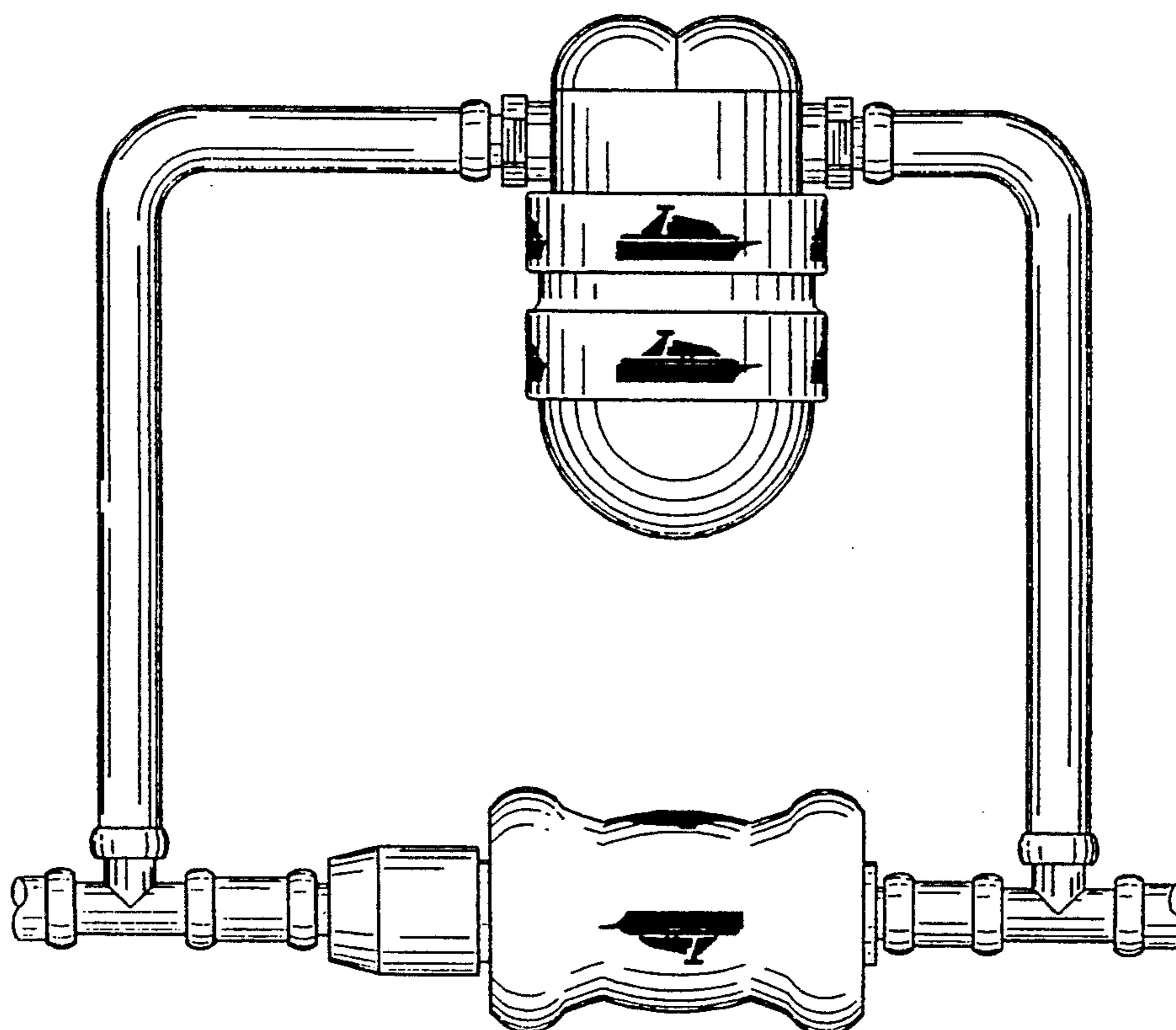

FIG. 3

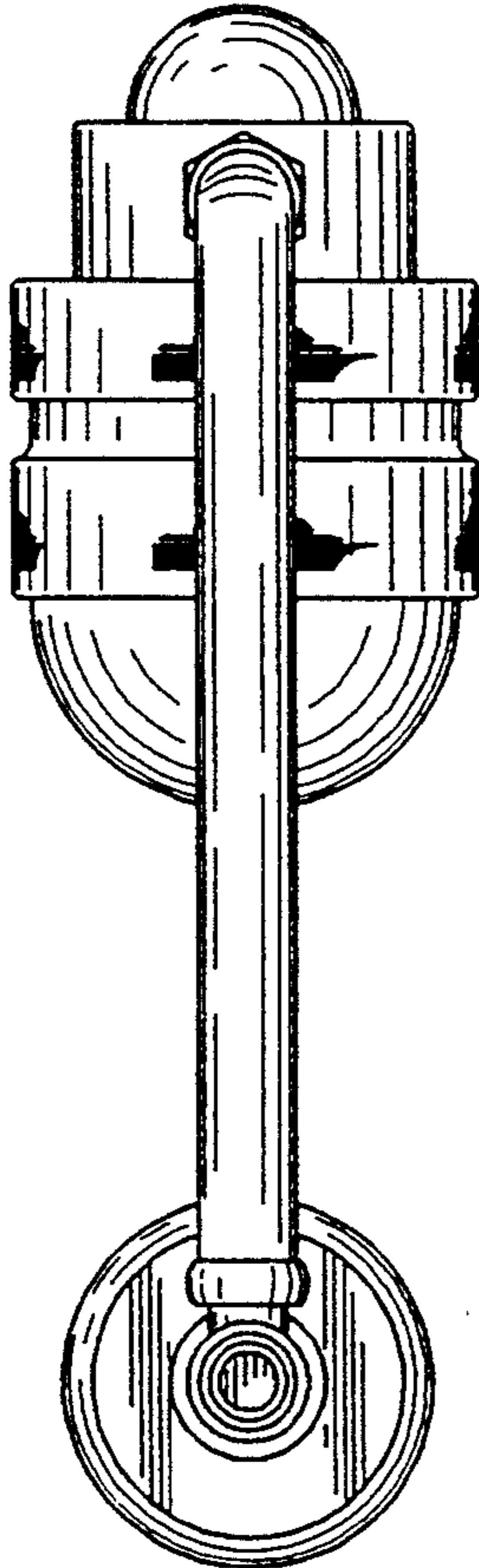

FIG. 4

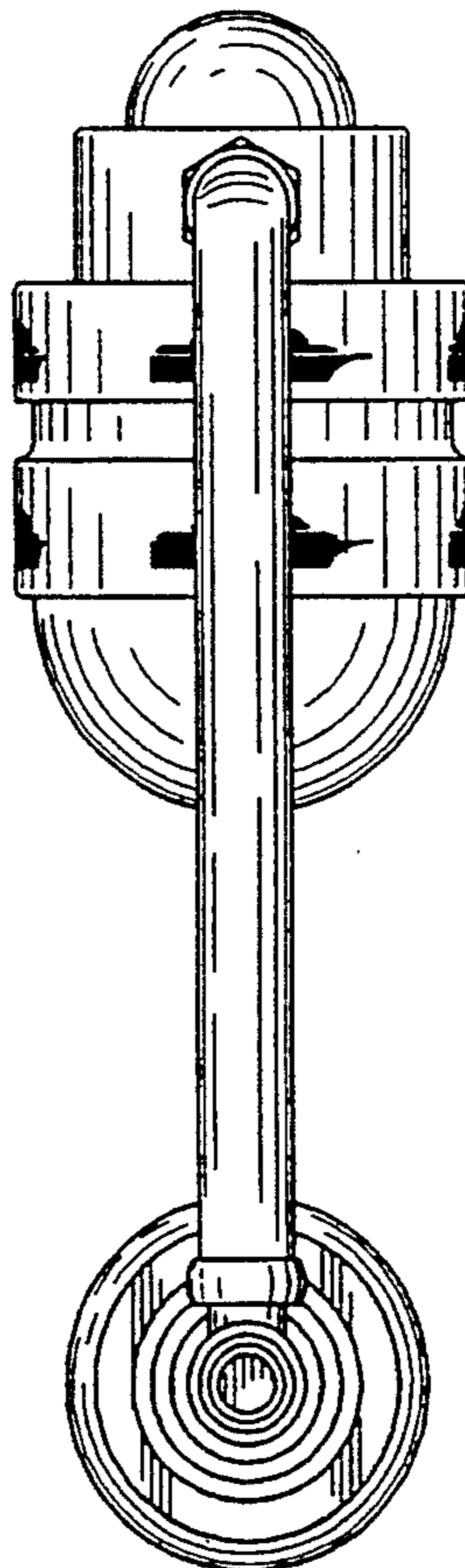

FIG. 5

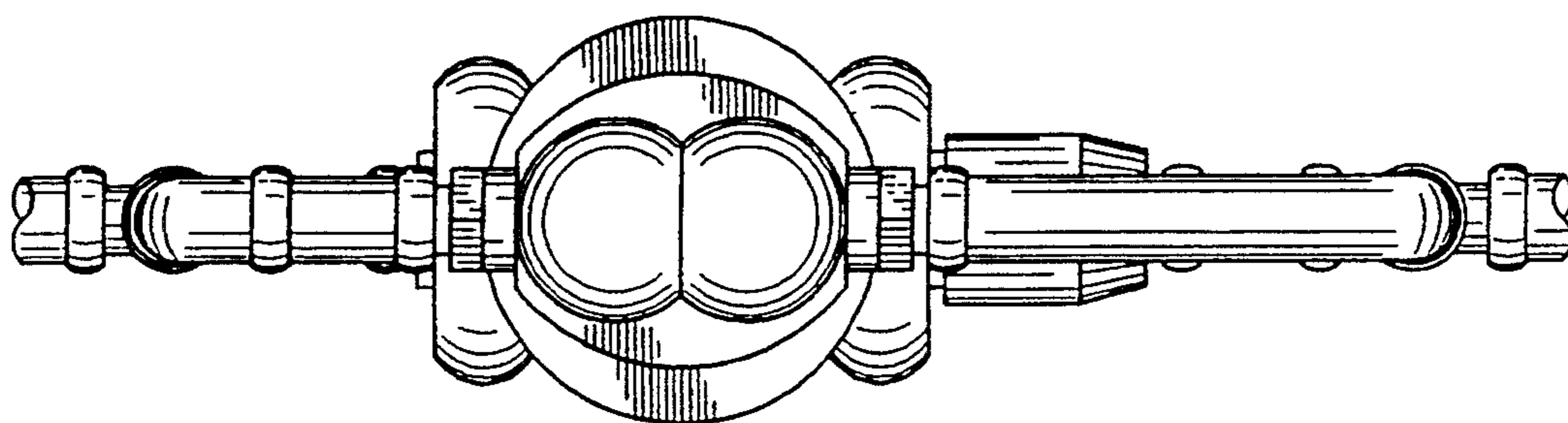

FIG. 6

