



US00D350724S

United States Patent [19]
Lichtbach

[11] **Patent Number: Des. 350,724**
[45] **Date of Patent: ** Sep. 20, 1994**

[54] **SPORT UTILITY RACK**
[76] Inventor: **Eric Lichtbach**, 9940 Richeon Ave.,
Downey, Calif. 90240
[**] Term: **14 Years**
[21] Appl. No.: **15,487**
[22] Filed: **Nov. 18, 1993**
[52] U.S. Cl. **D12/412**
[58] **Field of Search** 296/3, 26, 27, 100;
224/42.44 R, 42.45 R, 309, 315; D12/406, 412

5,238,288 8/1993 Chandler 296/26

Primary Examiner—James M. Gandy
Assistant Examiner—M. Brown
Attorney, Agent, or Firm—Ladas & Parry

[57] **CLAIM**

The ornamental design for a sport utility rack, as shown and described.

DESCRIPTION

FIG. 1 is a top, front and left side perspective view of a sport utility rack showing my new design, the broken lines are for illustrative purposes only and form no part of the claimed design;
FIG. 2 is a front elevational view thereof;
FIG. 3 is a right side elevational view thereof;
FIG. 4 is a rear elevational view thereof;
FIG. 5 is a top plan view thereof;
FIG. 6 is a bottom plan view thereof; and,
FIG. 7 is a cross-sectional view taken on line 7—7 of FIG. 4.

[56] **References Cited**
U.S. PATENT DOCUMENTS
D. 239,618 4/1976 Duer et al. D12/412
D. 244,268 5/1977 Hinch 224/42.45 R
D. 298,819 12/1988 Holmström D12/412
D. 305,111 12/1989 Zagner D12/412
D. 318,447 7/1991 Haugen et al. D12/412
4,770,458 9/1988 Burke et al. D12/412

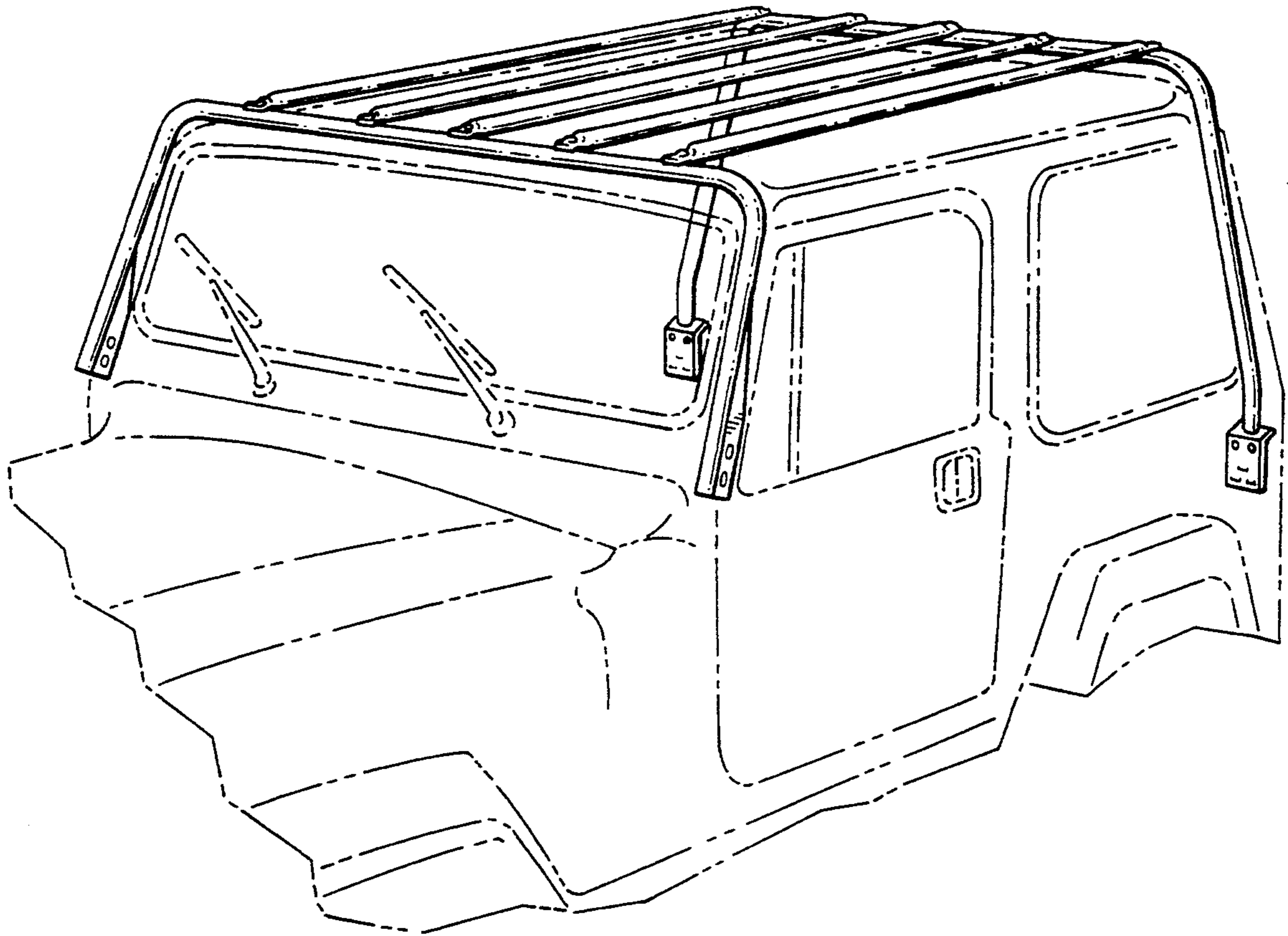

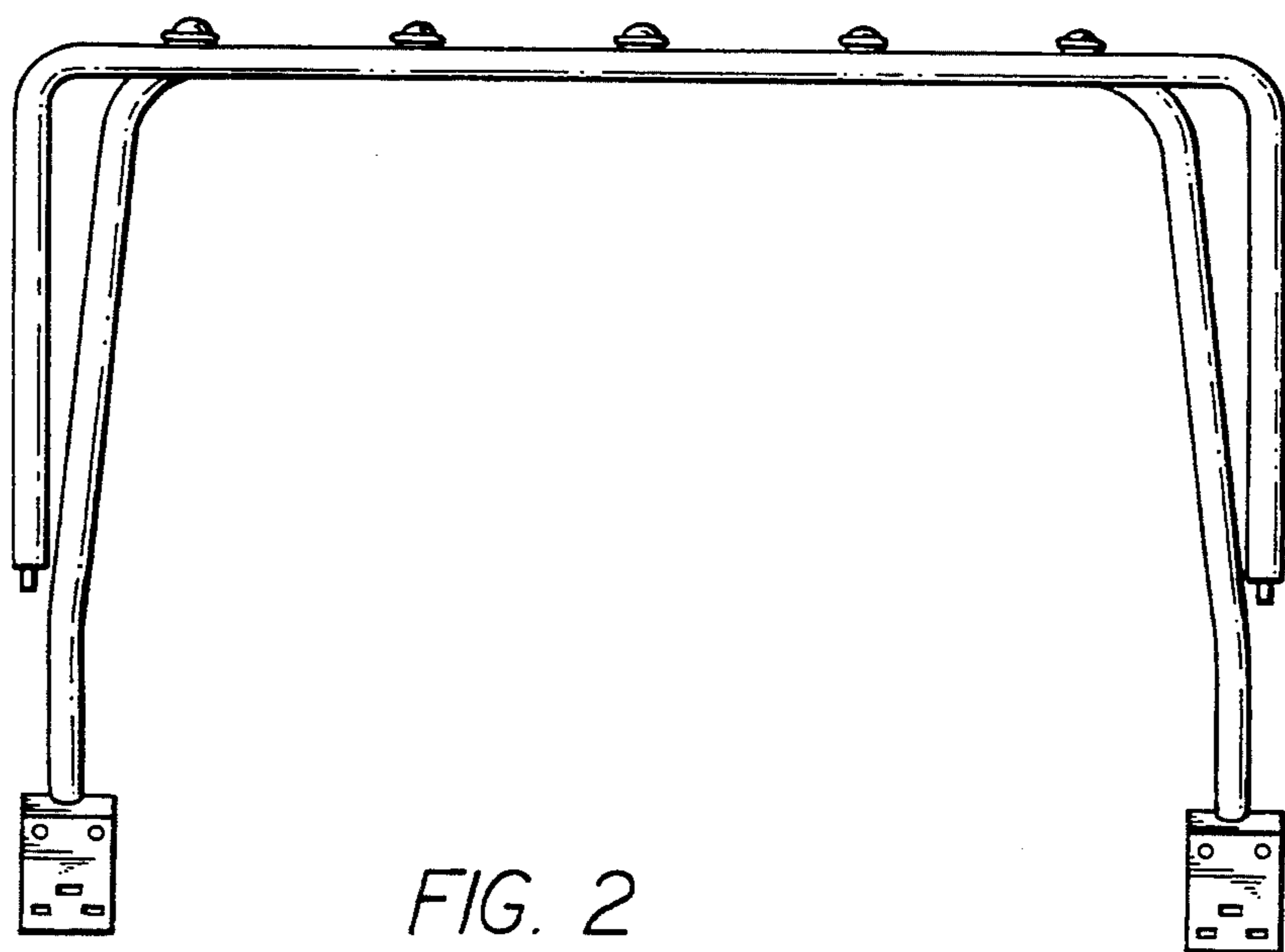
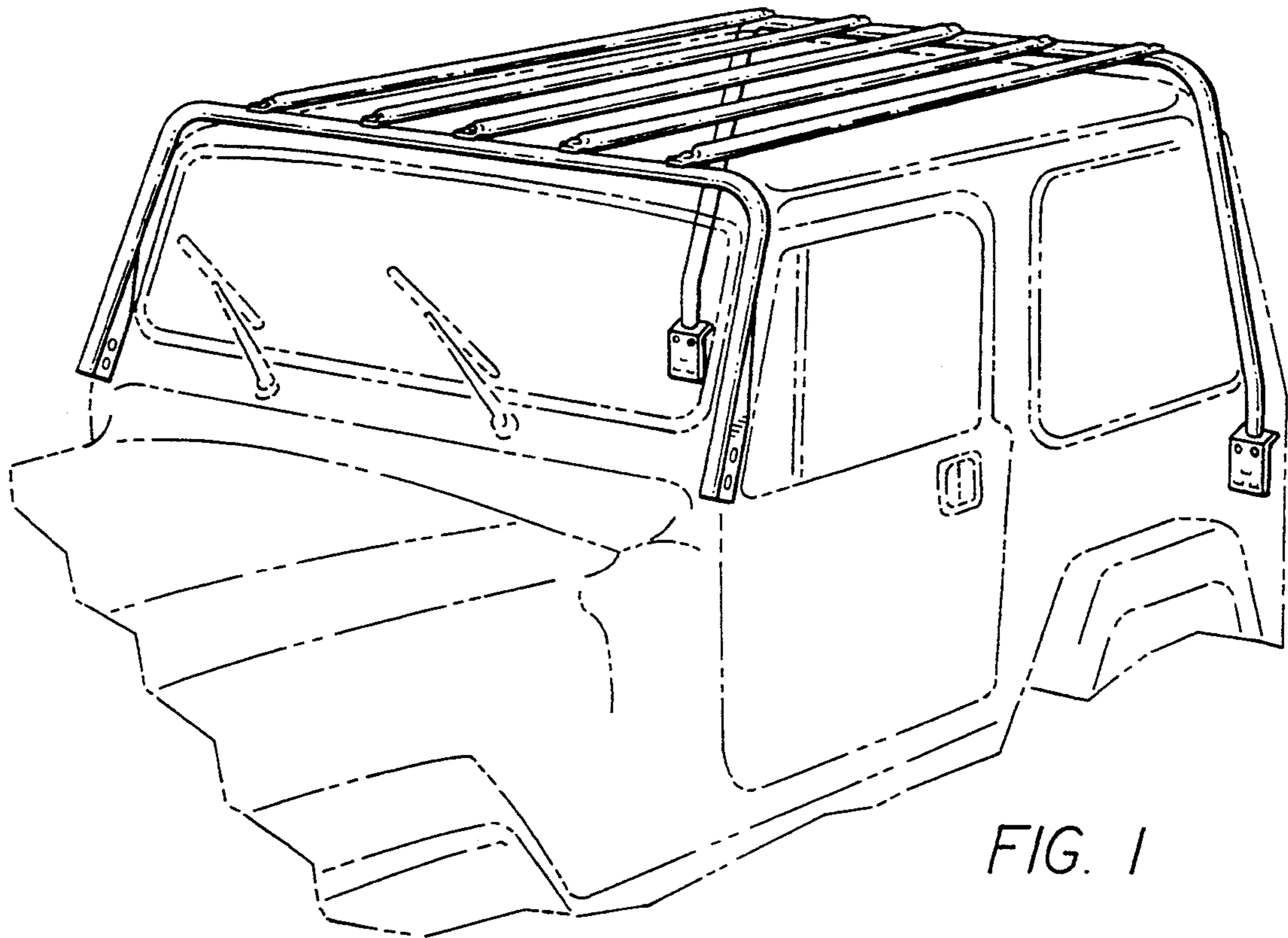

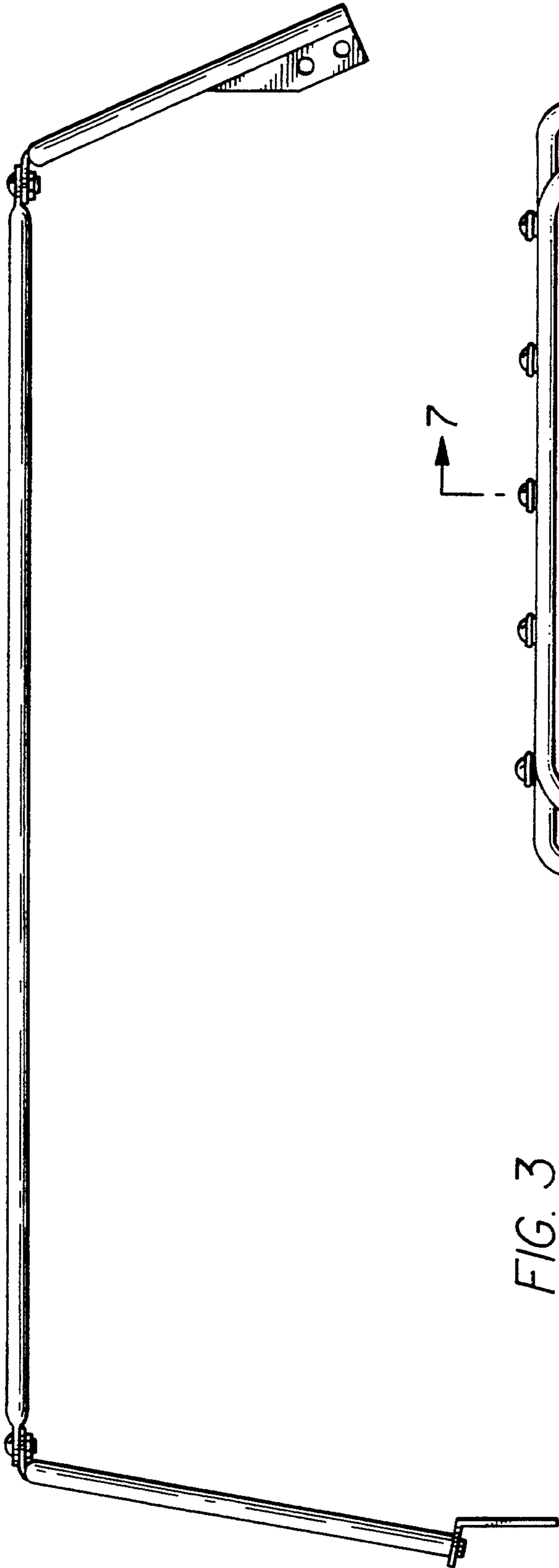

FIG. 3

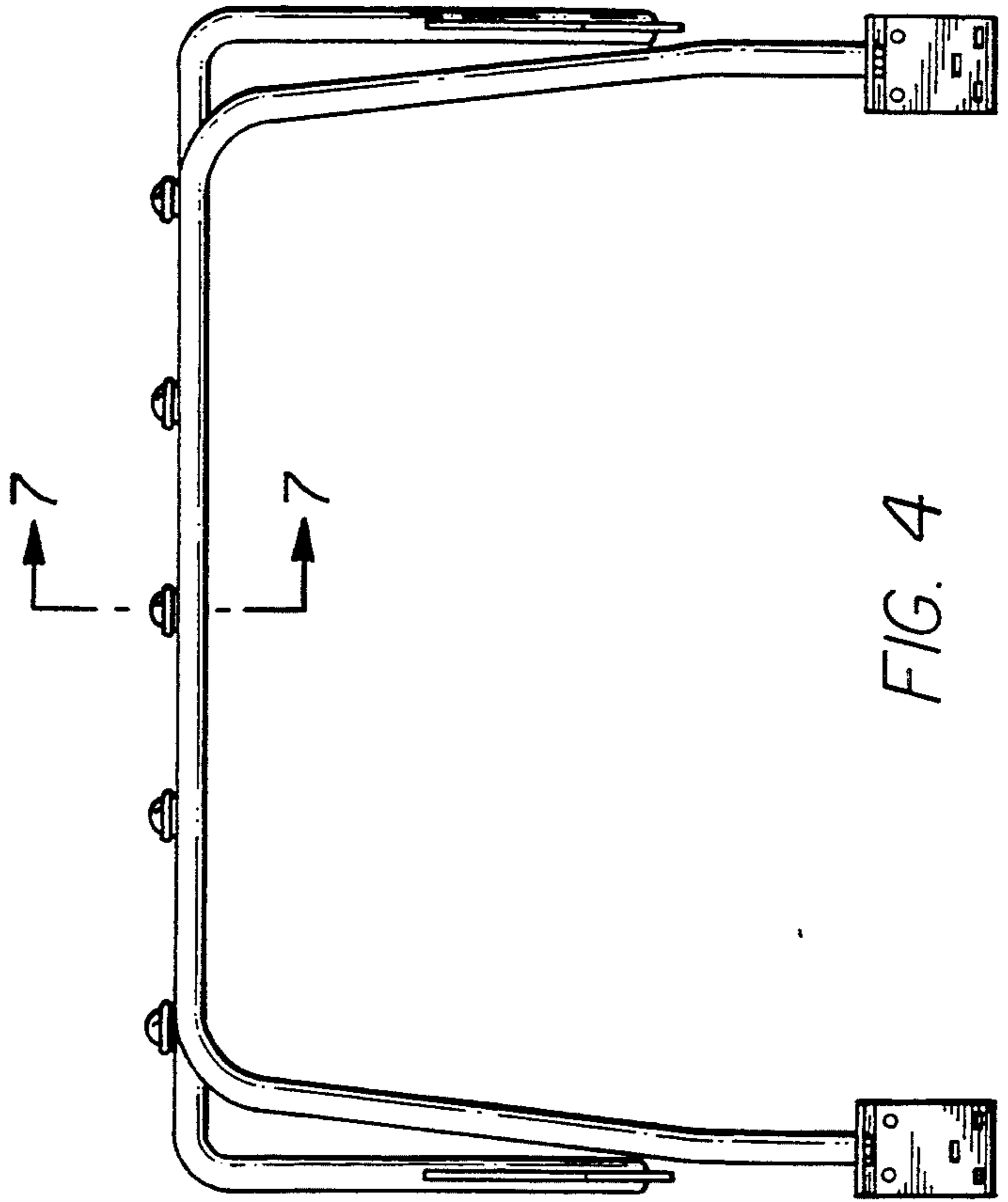

FIG. 4

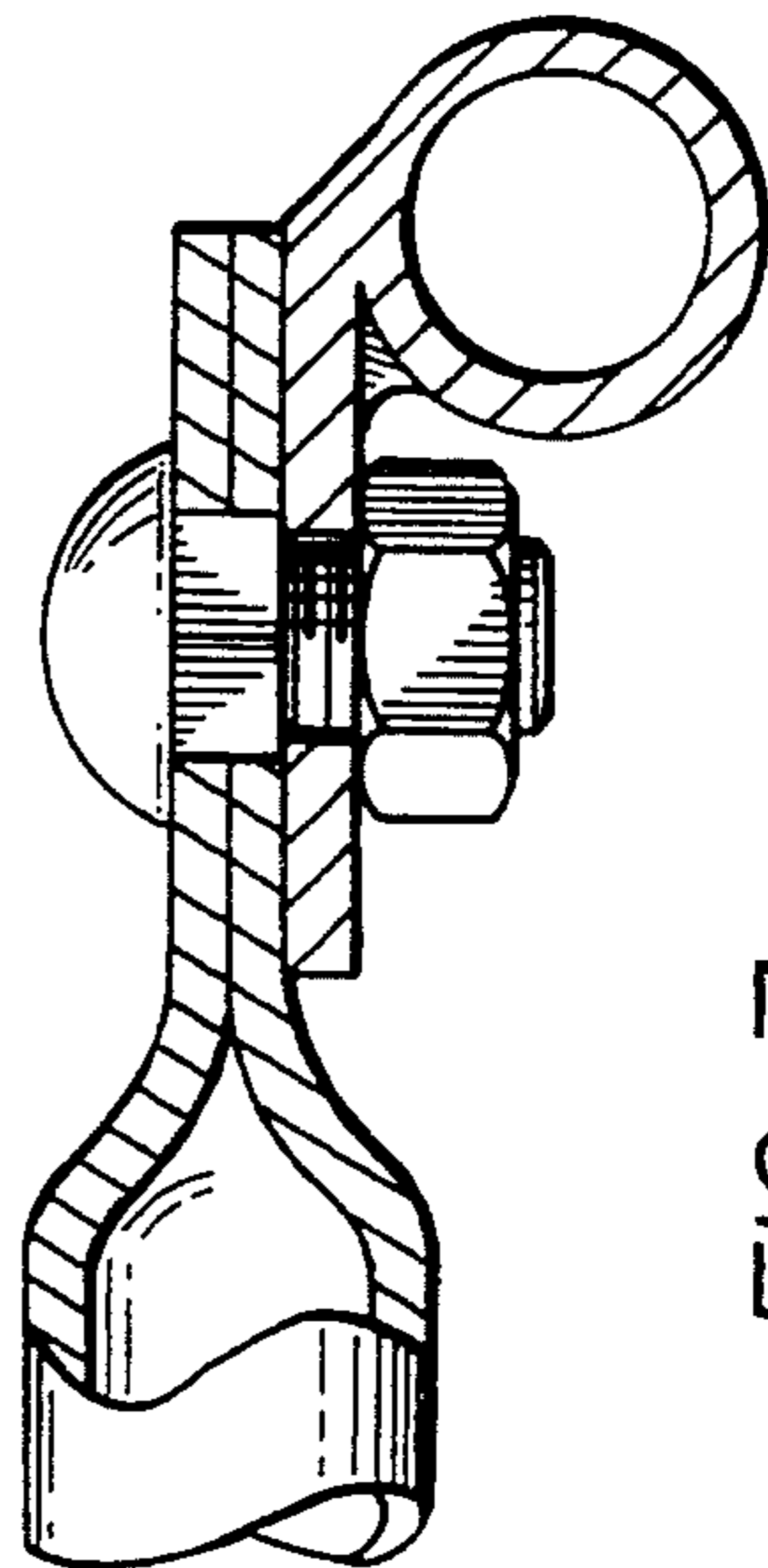

FIG. 7

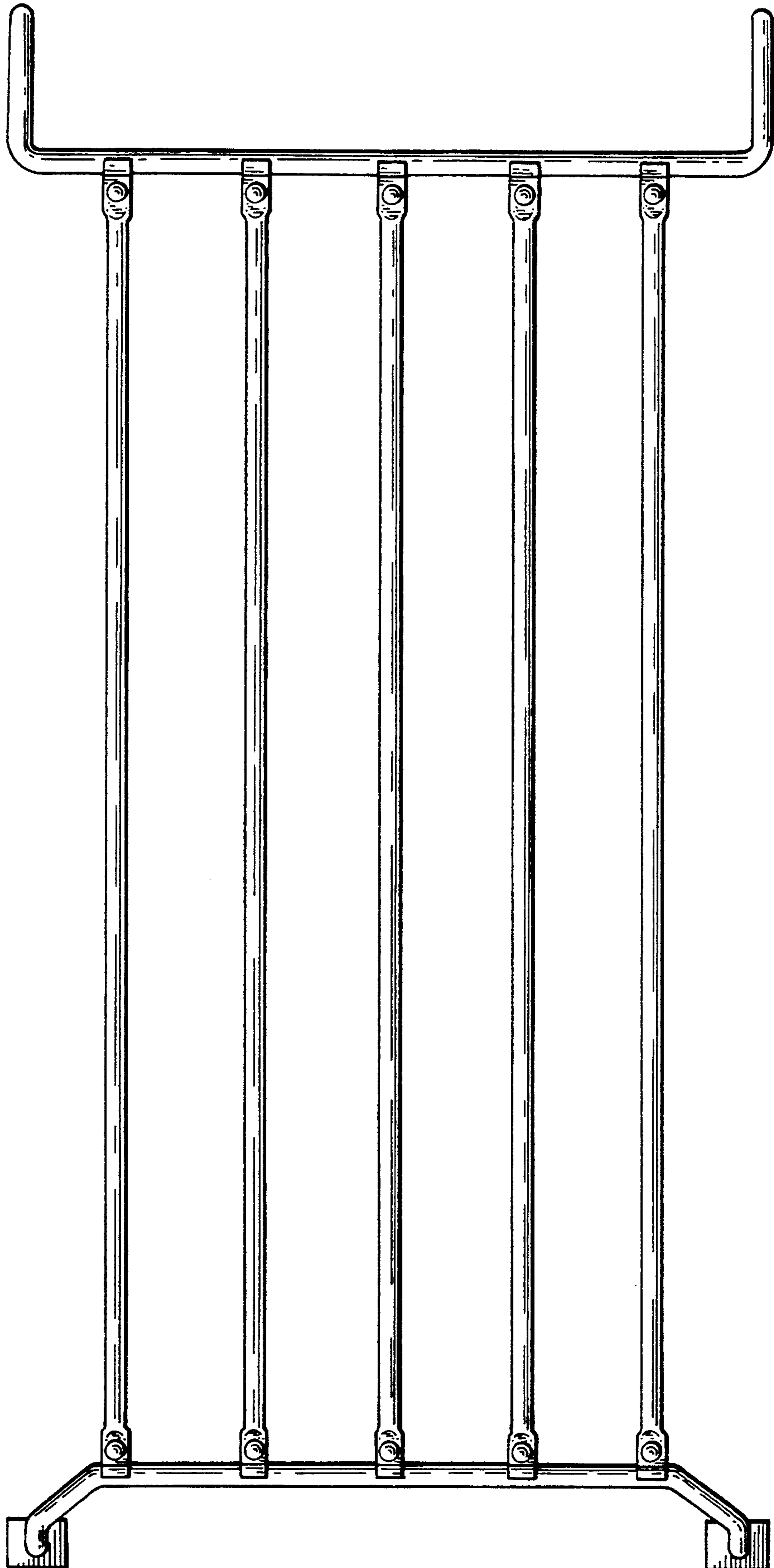

FIG. 5

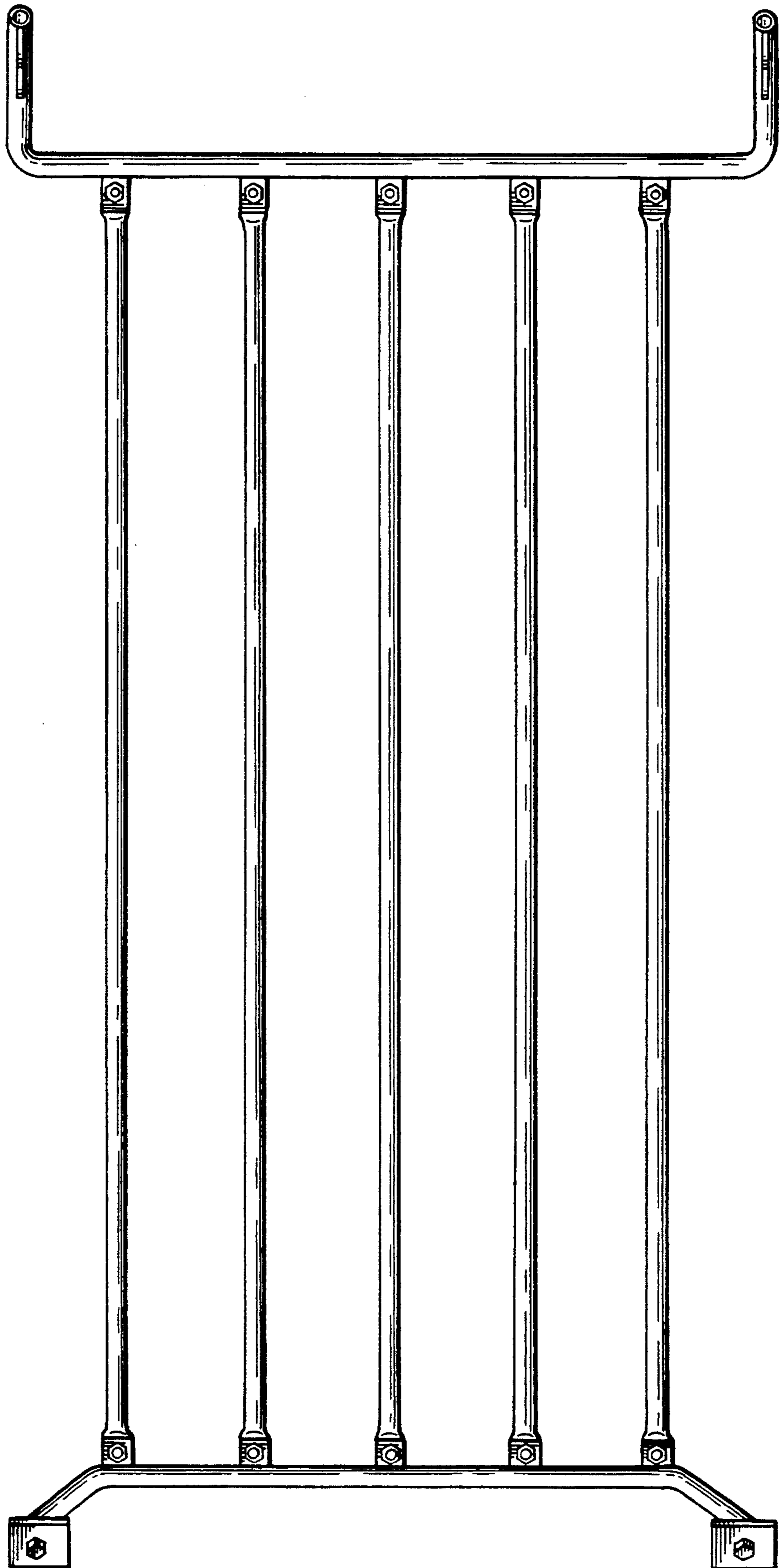

FIG. 6