



US00D350517S

United States Patent [19]

[11] Patent Number: **Des. 350,517**

Steinke et al.

[45] Date of Patent: **** Sep. 13, 1994**

[54] **DISK BRAKE SHIM**

5,033,590 7/1991 Kobayashi et al. 188/250 B
5,141,083 8/1991 Burgoon 188/250 B

[75] Inventors: **Gustav J. Steinke**, Lima; **Karl L. Placke**, Delphos, both of Ohio

Primary Examiner—Wallace R. Burke

Assistant Examiner—M. Brown

[73] Assignee: **International Brake Industries, Inc.**, Lima, Ohio

Attorney, Agent, or Firm—Edgar A. Zarins; Malcolm L. Sutherland

[**] Term: **14 Years**

[57] **CLAIM**

[21] Appl. No.: **8,209**

The ornamental design for a disc brake shim, as shown and described.

[22] Filed: **May 12, 1993**

DESCRIPTION

Related U.S. Application Data

[62] Division of Ser. No. 797,265, Nov. 25, 1991, Pat. No. Des. 341,120.

[52] U.S. Cl. **D12/180**

[58] Field of Search 188/73.1, 250 B; **D12/180**

FIG. 1 is a perspective view of a disc brake shim showing our new design;
FIG. 2 is a front elevational view thereof;
FIG. 3 is a rear elevational view thereof;
FIG. 4 is a top plan view thereof;
FIG. 5 is a bottom plan view thereof;
FIG. 6 is a right side view thereof;
FIG. 7 is a left side view thereof; and,
FIG. 8 is a perspective view of a disc brake shim showing a second embodiment of our design, wherein the only difference resides in the bottom edge of the design.

[56] **References Cited**

U.S. PATENT DOCUMENTS

D. 279,467 7/1985 Eberhart et al. **D12/180**

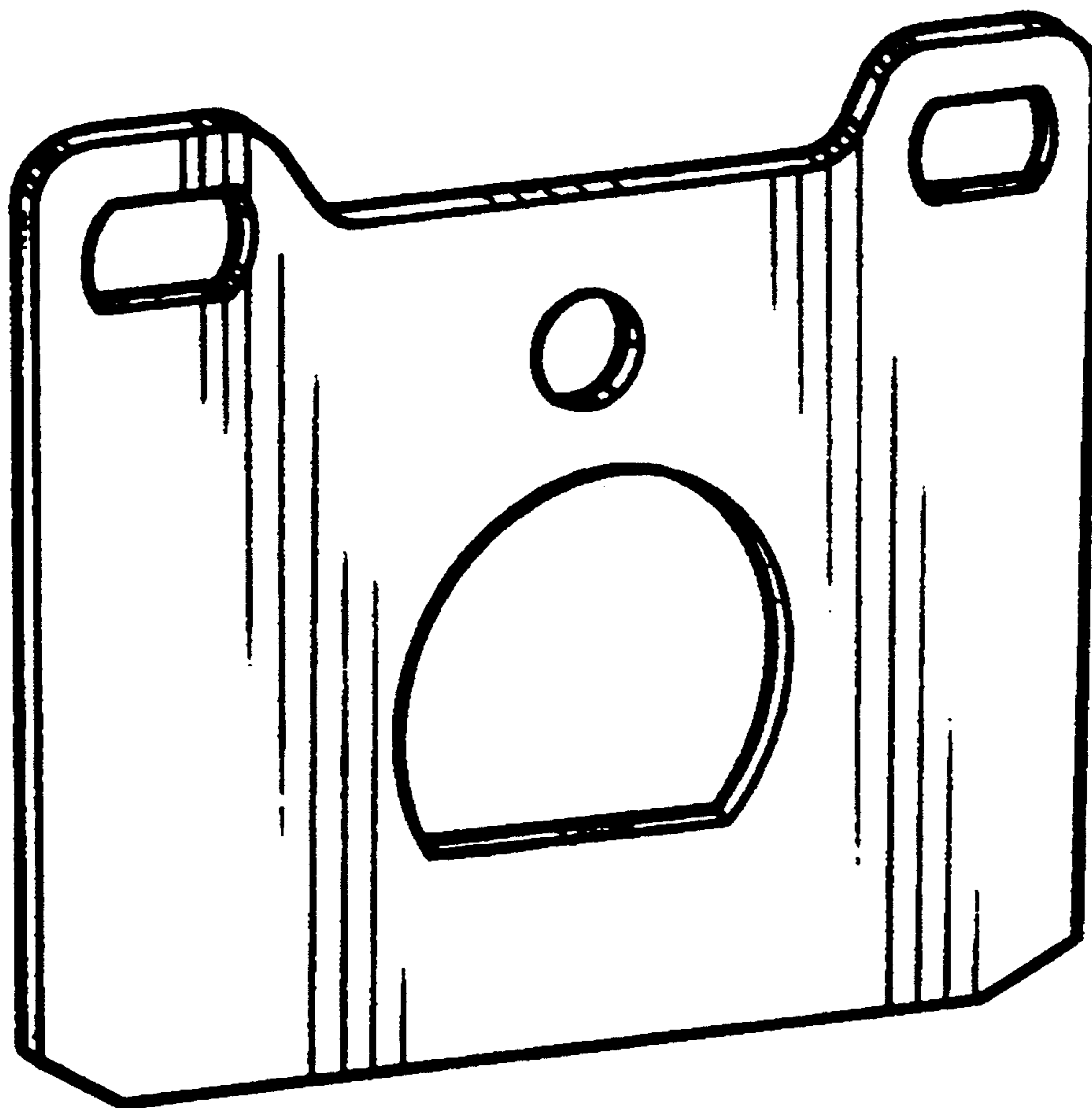

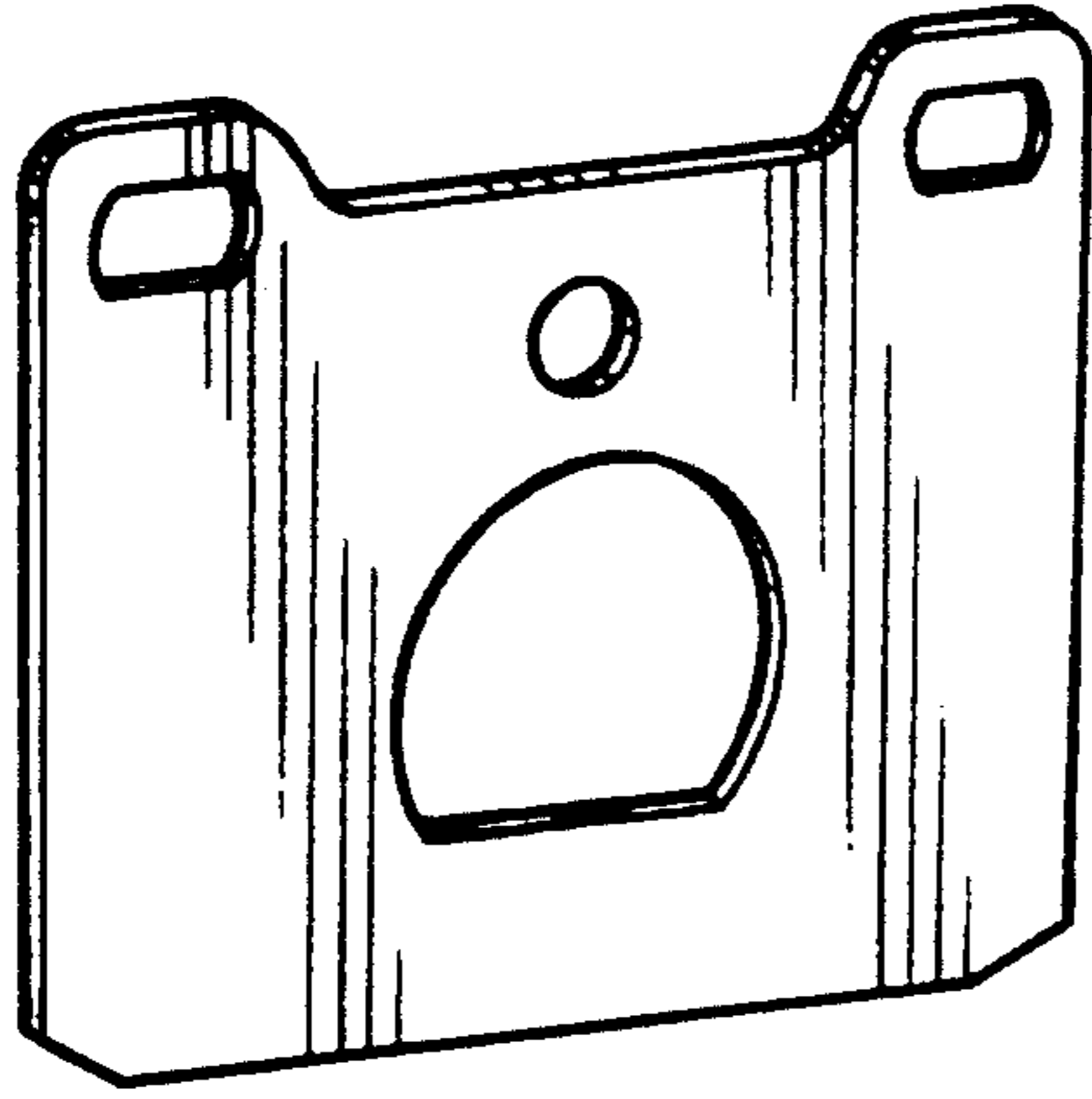

Fig-1

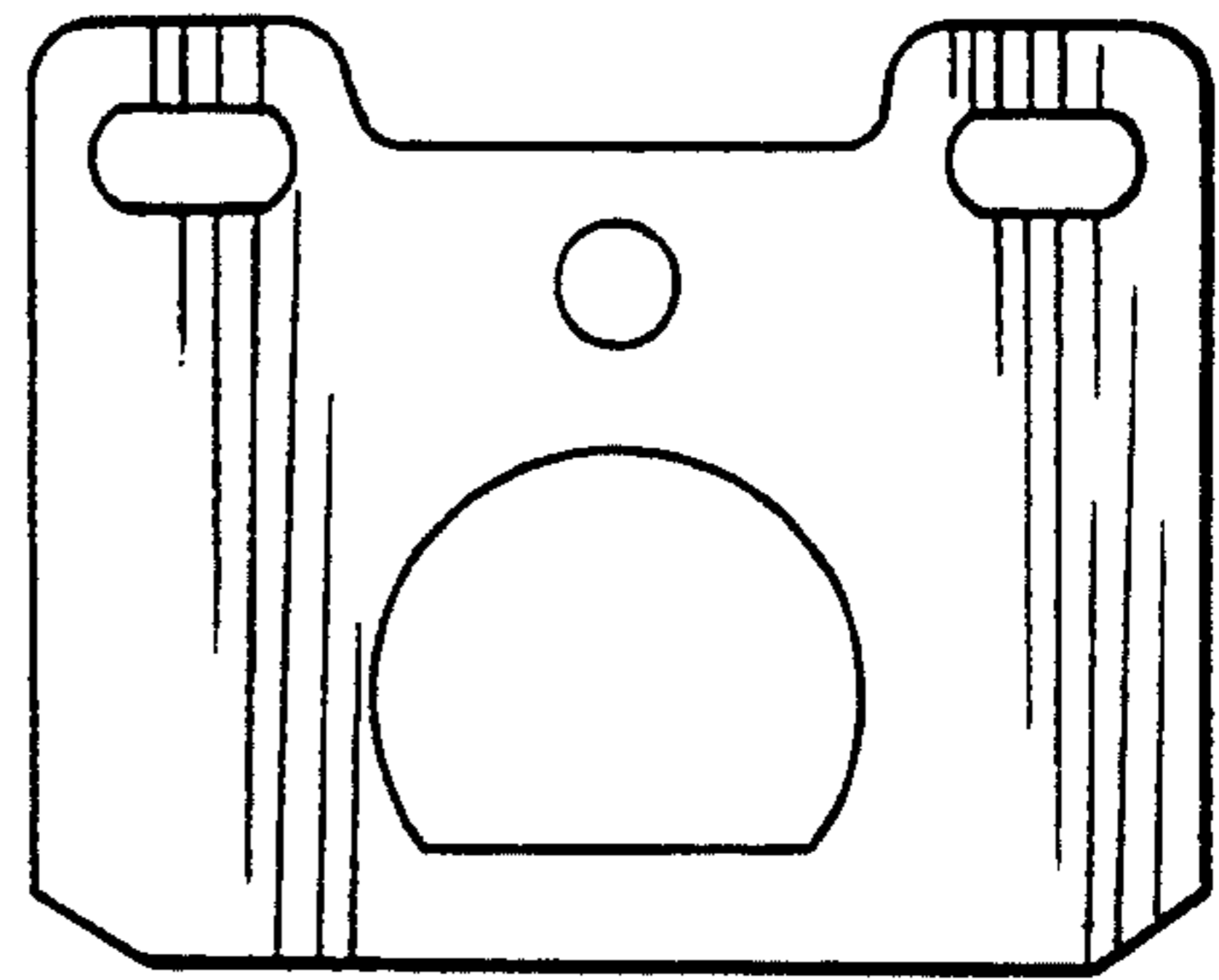

Fig-2

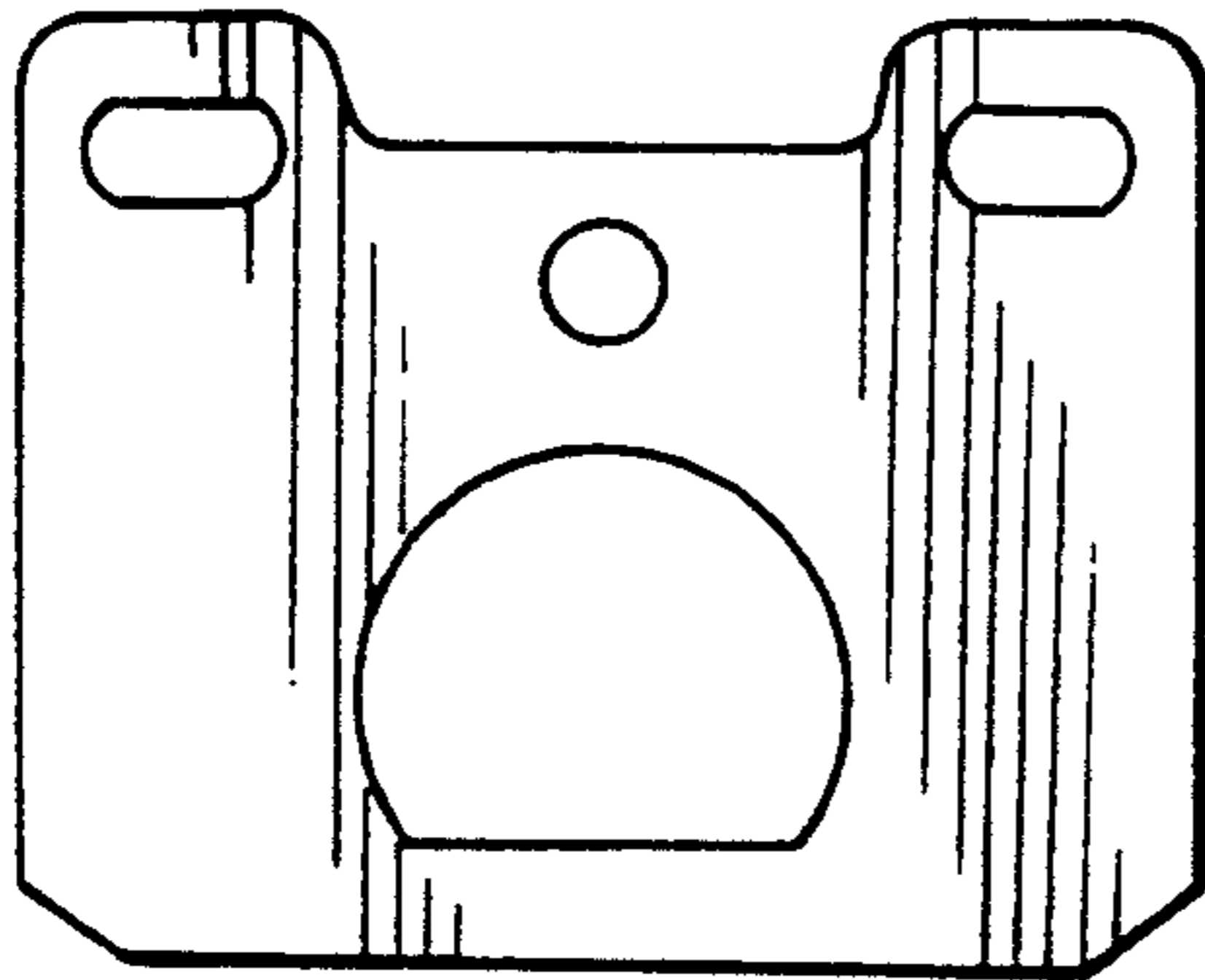

Fig-3



Fig-4

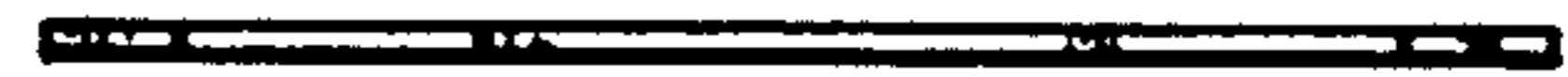

Fig-5



Fig-6



Fig-7

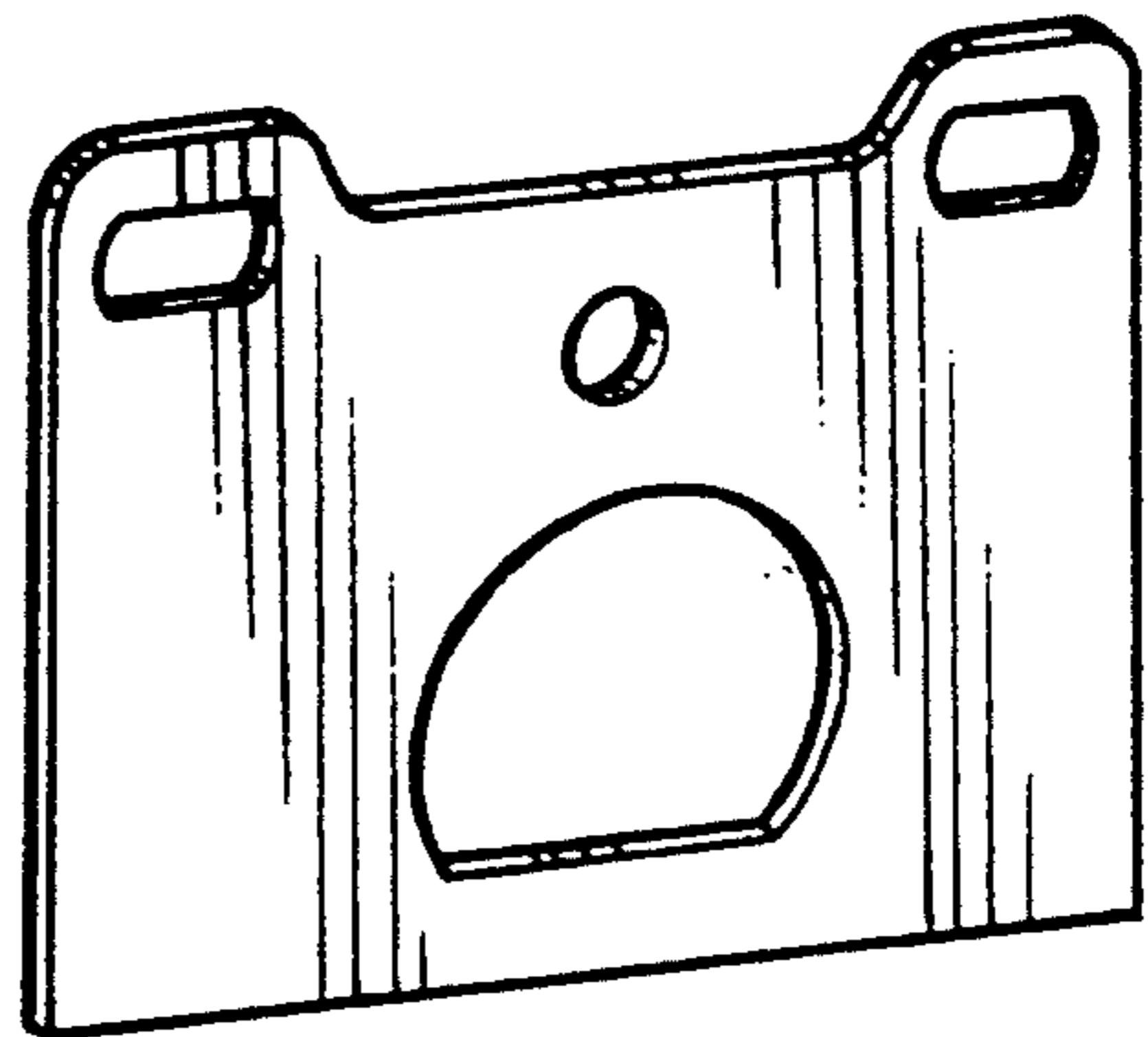

Fig-8