



US00D350358S

United States Patent [19]
Kaye

[11] **Patent Number: Des. 350,358**
[45] **Date of Patent: ** Sep. 6, 1994**

[54] **AIR BOAT TRANSMISSION HOUSING**

3,727,483 4/1973 Hanson et al. 74/609

[75] **Inventor: Bruce Kaye, Inverness, Fla.**

OTHER PUBLICATIONS

[73] **Assignee: K-Way Engineering, Inc., Cocoa, Fla.**

Loman Co.; Parallel Shaft Reducers; Nov. 1973; p. 2.

[**] **Term: 14 Years**

Primary Examiner—Alan P. Douglas
Assistant Examiner—Antoine O. Davis

[21] **Appl. No.: 7,296**

[57] **CLAIM**

[22] **Filed: Apr. 16, 1993**

The ornamental design for an air boat transmission housing, as shown and described.

[52] **U.S. Cl. D15/149**

[58] **Field of Search 74/609, 606 R; 244/230; D15/149**

DESCRIPTION

[56] **References Cited**

U.S. PATENT DOCUMENTS

D. 324,866 3/1992 Pleet et al. D15/149 XZ
1,813,819 7/1931 Ross 74/609

FIG. 1 is a front, left and top perspective view of an air boat transmission housing showing my new design; FIG. 2 is a front elevational view; FIG. 3 is a left side elevational view; FIG. 4 is a bottom plan view; and, FIG. 5 is a top plan view thereof.

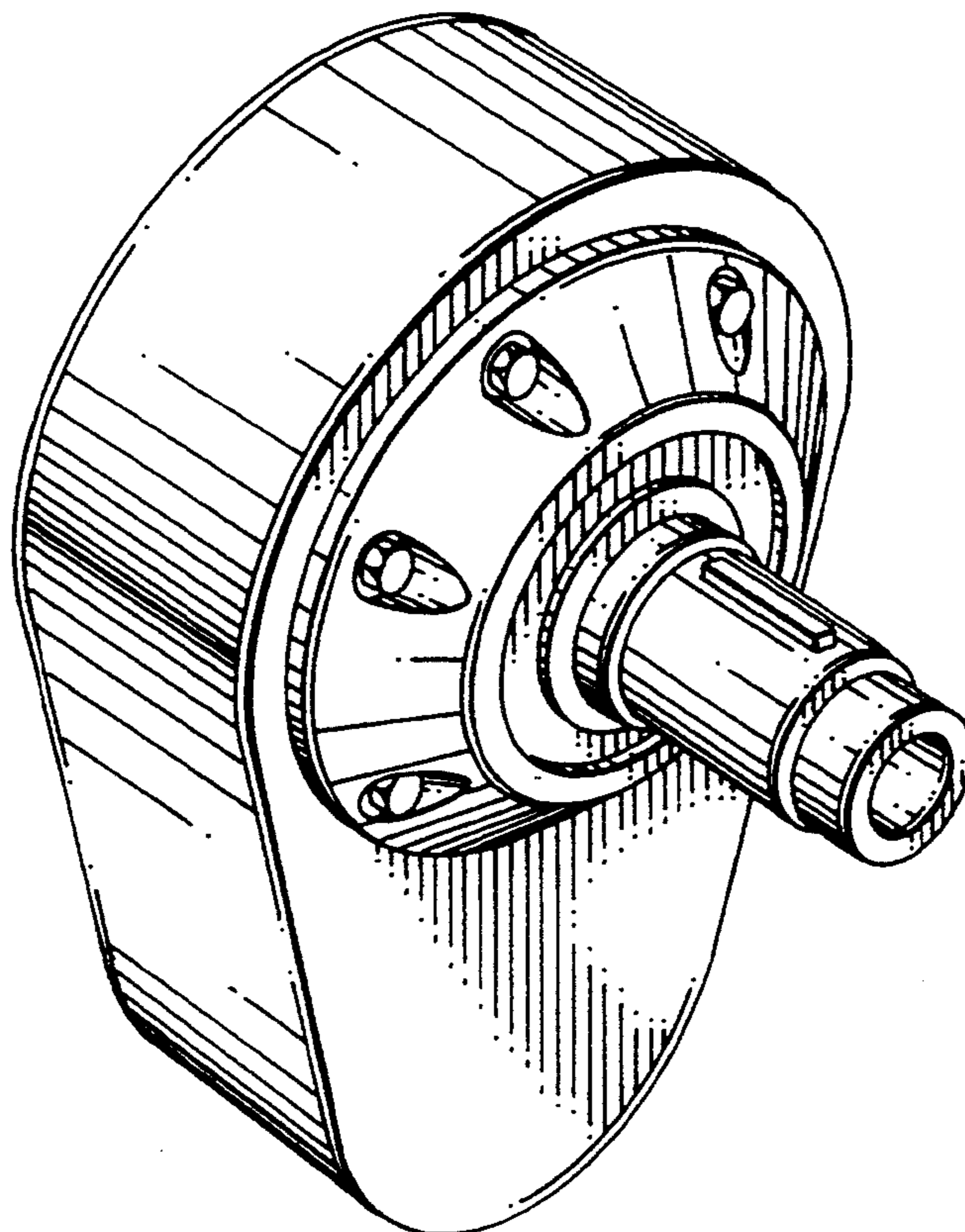

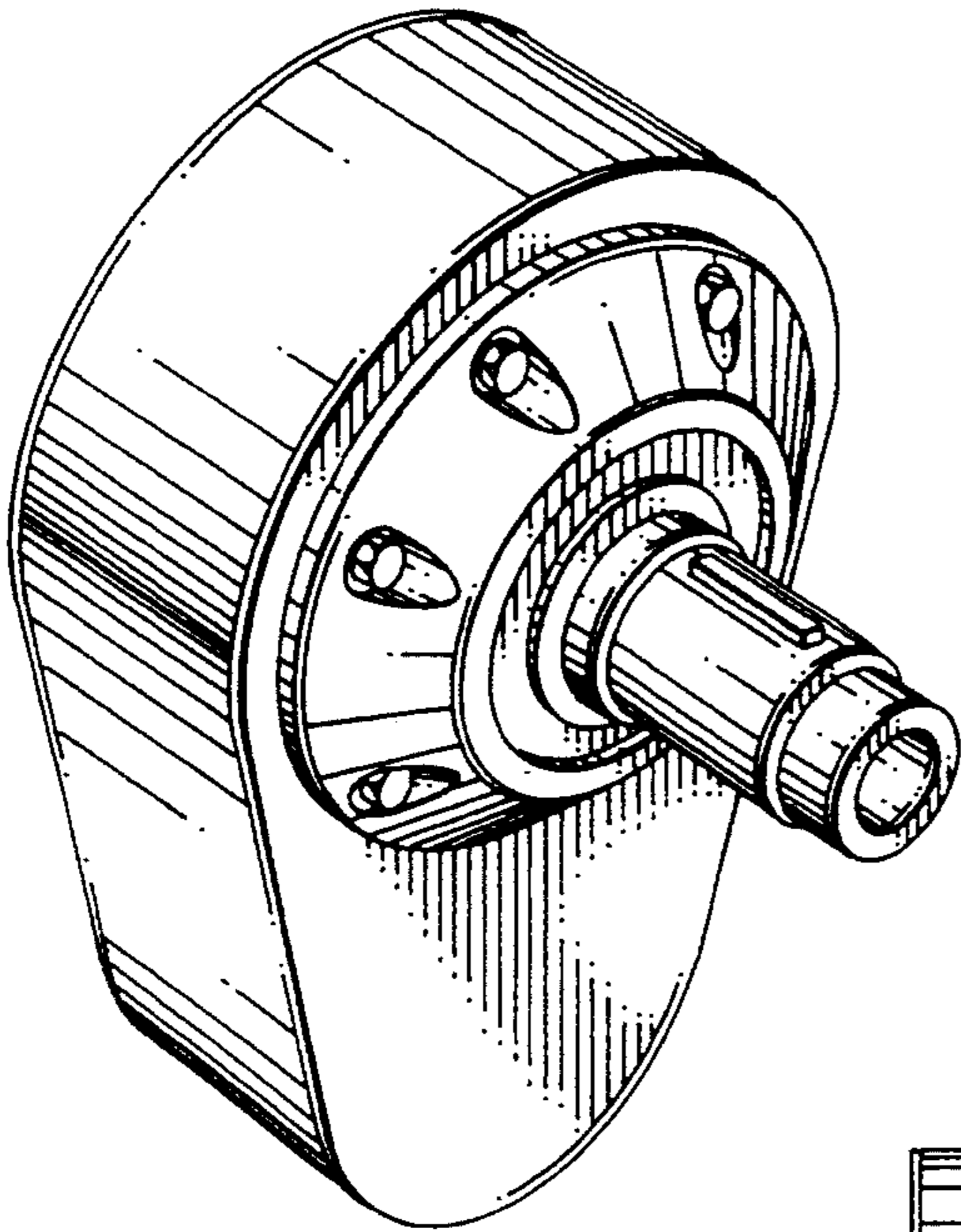

FIG. 1

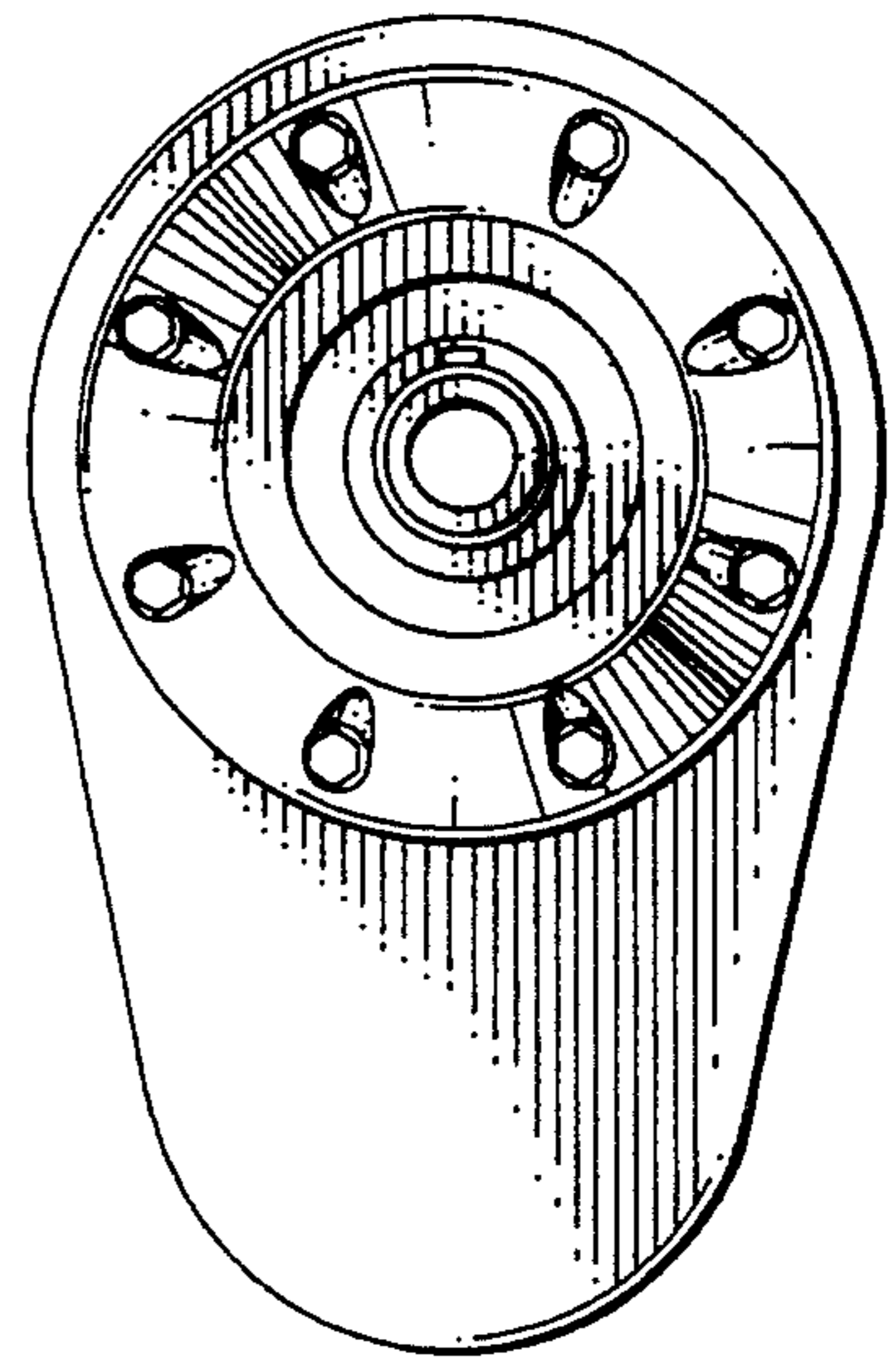

FIG. 2

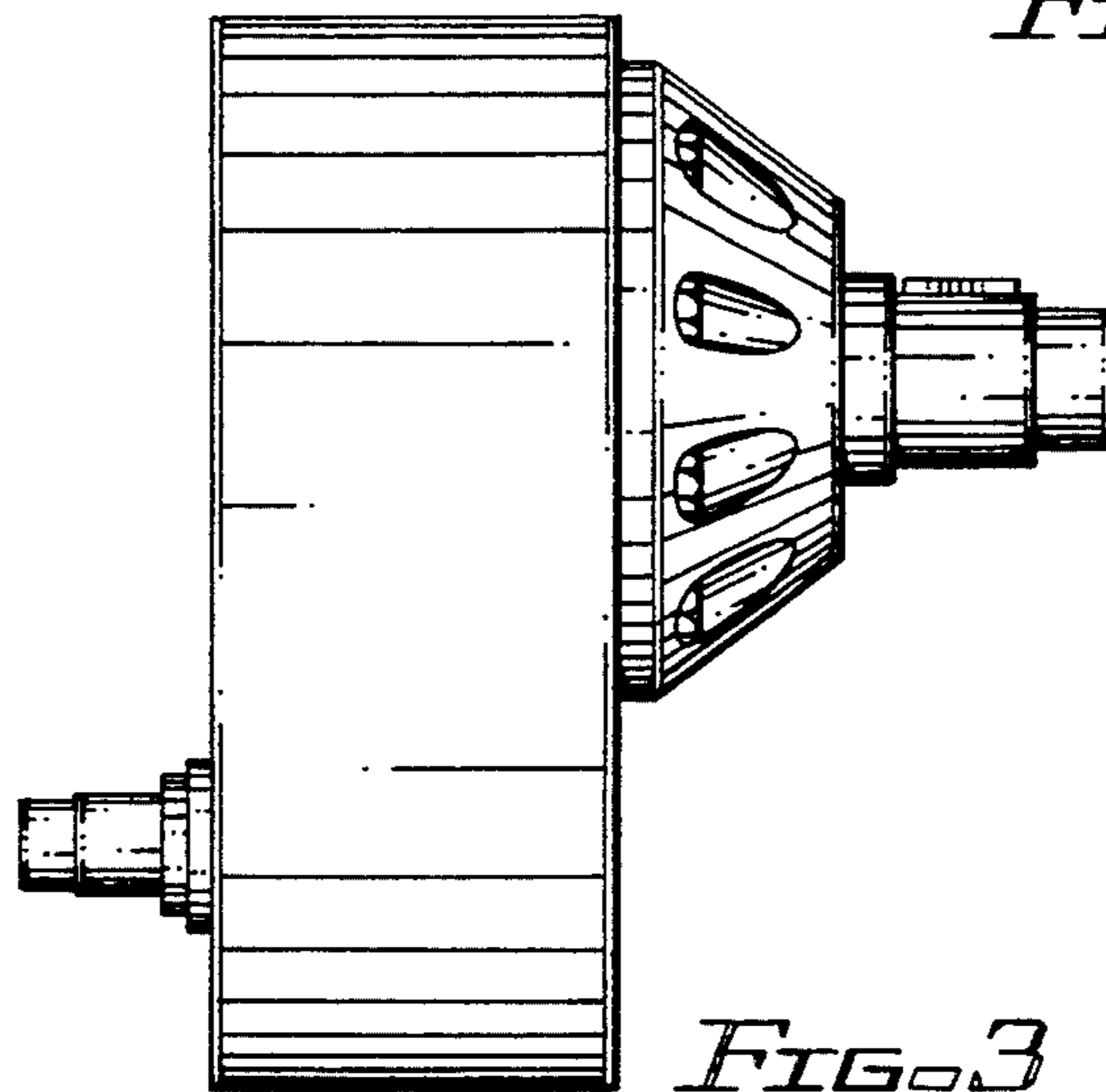

FIG. 3

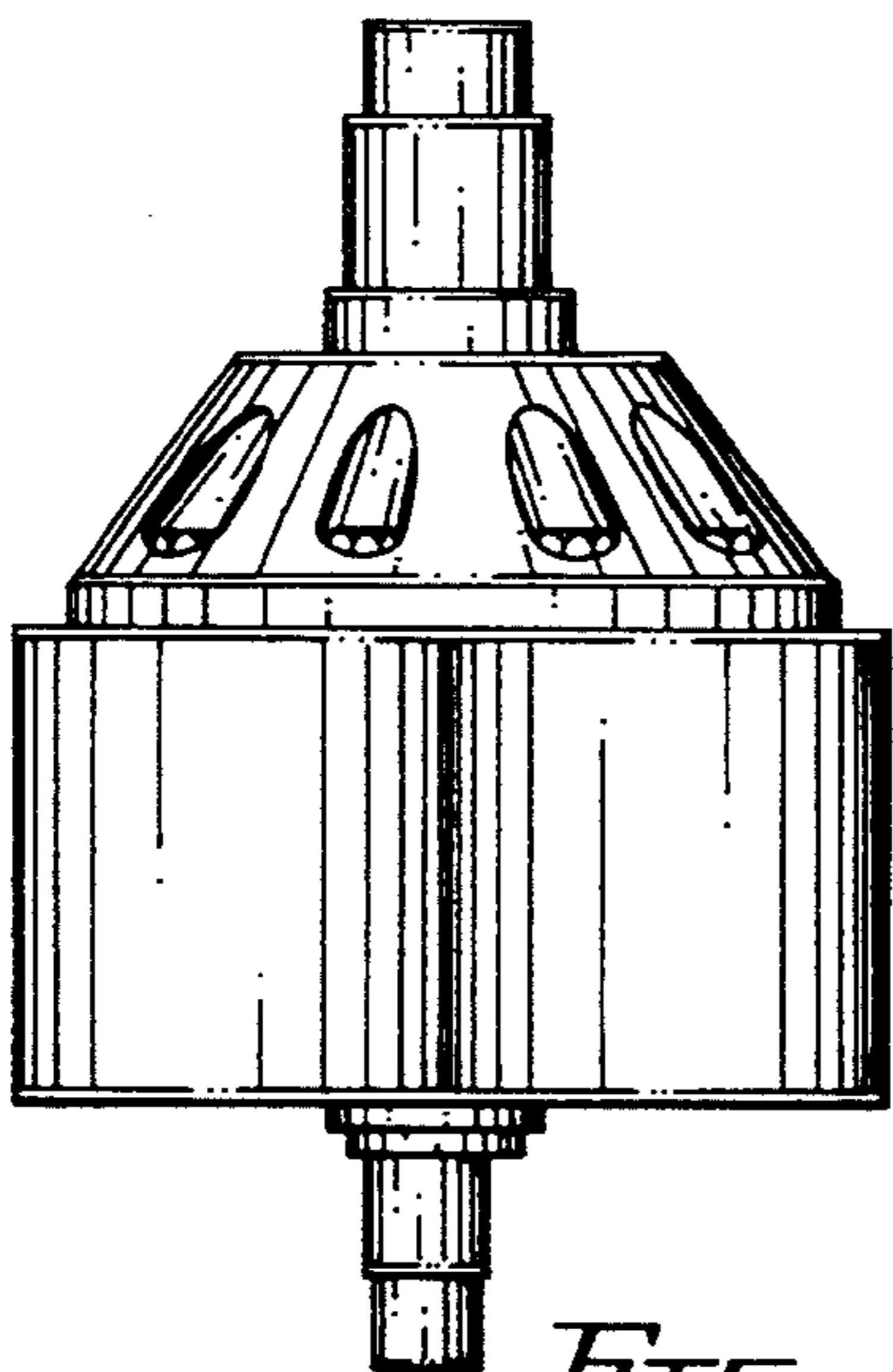

FIG. 4

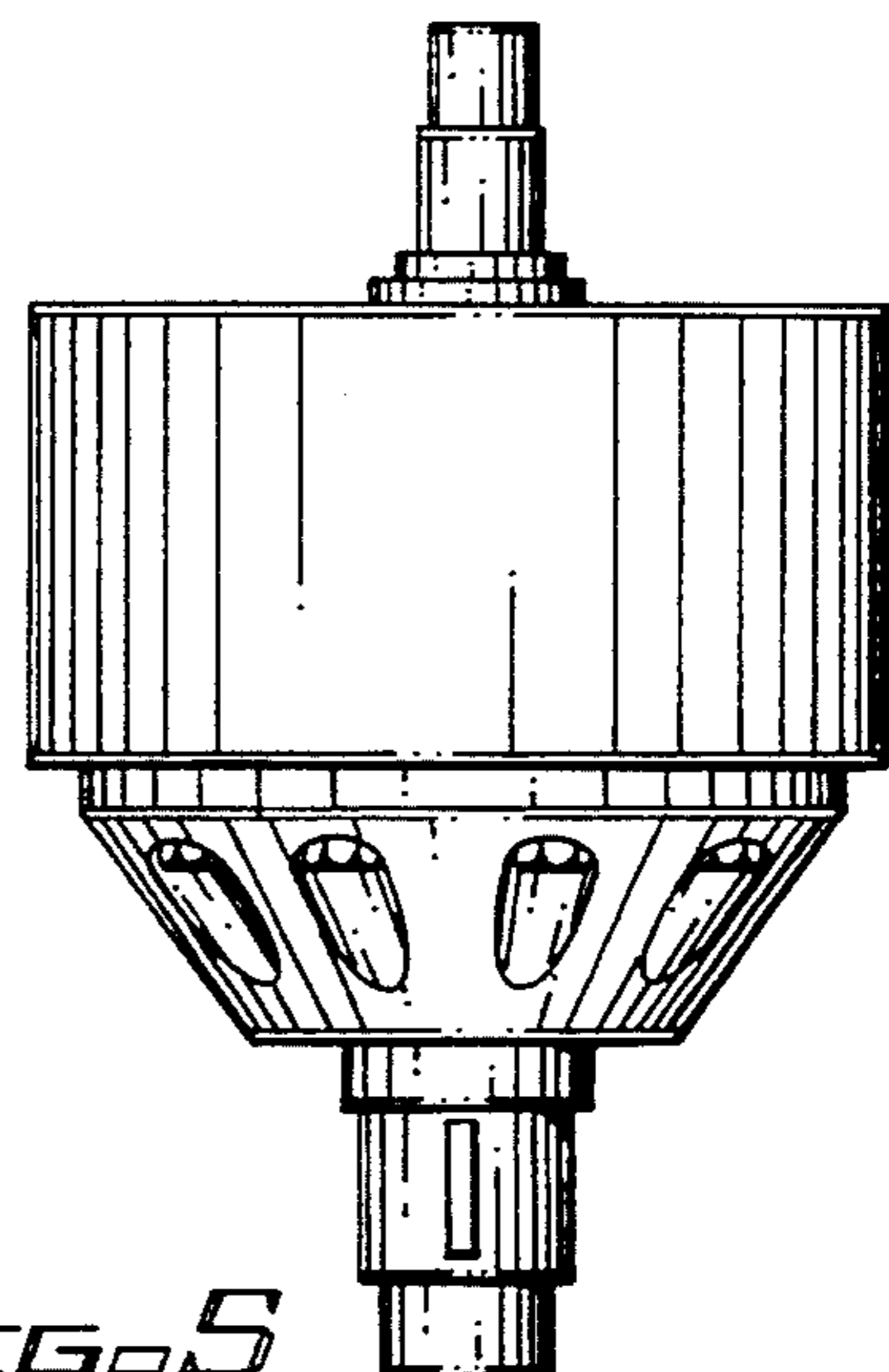

FIG. 5