



US00D350332S

# United States Patent [19] Hoffman

[11] Patent Number: **Des. 350,332**

[45] Date of Patent: **\*\* Sep. 6, 1994**

[54] **DEAD FRONT ELECTRICAL CONNECTOR FOR CHARGING ELECTRIC CARS**

[75] Inventor: **Ernest G. Hoffman**, Middlefield, Conn.

[73] Assignee: **Hubbell Incorporated**, Orange, Conn.

[\*\*] Term: **14 Years**

[21] Appl. No.: **7,891**

[22] Filed: **Apr. 30, 1993**

[52] U.S. Cl. .... **D13/133**

[58] Field of Search ..... 439/131, 136, 261, 266, 439/310, 345, 350, 481, 483, 490, 923; D4/129, 138; D13/133, 146, 147; D32/50, 51

[56] **References Cited**

**U.S. PATENT DOCUMENTS**

D. 240,172	6/1976	Roettgen	.....	D4/138
D. 251,160	2/1979	Kelly, III et al.	.....	D4/129
D. 271,687	12/1983	Griffiths	.....	D13/168
D. 287,173	12/1986	Libman	.....	D32/51
D. 296,022	5/1988	Restivo	.....	D32/51
D. 307,517	5/1990	Mallory et al.	.....	D32/50 X
3,950,059	4/1976	Anhalt et al.	.....	339/75
3,952,239	4/1976	Owings et al.	.....	320/2
4,158,802	6/1979	Rose, II	.....	302/2
4,217,019	8/1980	Cameron	.....	439/138
4,431,241	2/1984	Hazelhurt	.....	339/43
4,624,472	11/1986	Stuart et al.	.....	280/420
4,718,862	1/1988	Beeman	.....	439/482
4,843,477	6/1989	Mizutani et al.	.....	358/248
5,104,331	4/1992	Goble	.....	439/490
5,157,319	10/1992	Klontz et al.	.....	320/2

**FOREIGN PATENT DOCUMENTS**

0049625	4/1982	European Pat. Off.	.....	439/345
1926582	11/1970	Fed. Rep. of Germany	.....	439/345
208053	5/1966	U.S.S.R.	.....	439/350

**OTHER PUBLICATIONS**

"Infrastructure-EV Charging Meter", Green Car Journal, Nov. 1992, p. 124.

*Primary Examiner*—Wallace R. Burke

*Assistant Examiner*—Joel Sincavage

*Attorney, Agent, or Firm*—Jerry M. Presson; David L. Tarnoff

[57] **CLAIM**

The ornamental design for a dead front electrical connector for charging electric cars, as shown and described.

**DESCRIPTION**

FIG. 1 is a rear perspective view of a dead front electrical connector for charging electric cars showing the first embodiment of my new design. The broken line showing the electrical cable throughout the drawing figures is included for the purpose of illustrating environmental structure only and forms no part of the claimed design;

FIG. 2 is a front perspective view of a dead front electrical connector for charging electric cars shown in FIG. 1;

FIG. 3 is a right side elevational view of the dead front electrical connector for charging electric cars shown in FIGS. 1-2;

FIG. 4 is a front elevational view of the dead front electrical connector for charging electric cars shown in FIGS. 1-3;

FIG. 5 is a rear elevational view of the dead front electrical connector for charging electric cars shown in FIGS. 1-4;

FIG. 6 is a top plan view of the dead front electrical connector for charging electric cars shown in FIGS. 1-5;

FIG. 7 is a bottom plan view of the dead front electrical connector for charging electric cars shown in FIGS. 1-6;

FIG. 8 is a rear perspective view of a dead front electrical connector for charging electric cars showing a second embodiment of my new design;

FIG. 9 is a front perspective view of a dead front electrical connector for charging electric cars shown in FIG. 8;

FIG. 10 is a right side elevational view of the dead front electrical connector for charging electric cars shown in FIGS. 8 and 9;

FIG. 11 is a front elevational view of the dead front electrical connector for charging electric cars shown in FIGS. 8-10;

(Continued on next page.)

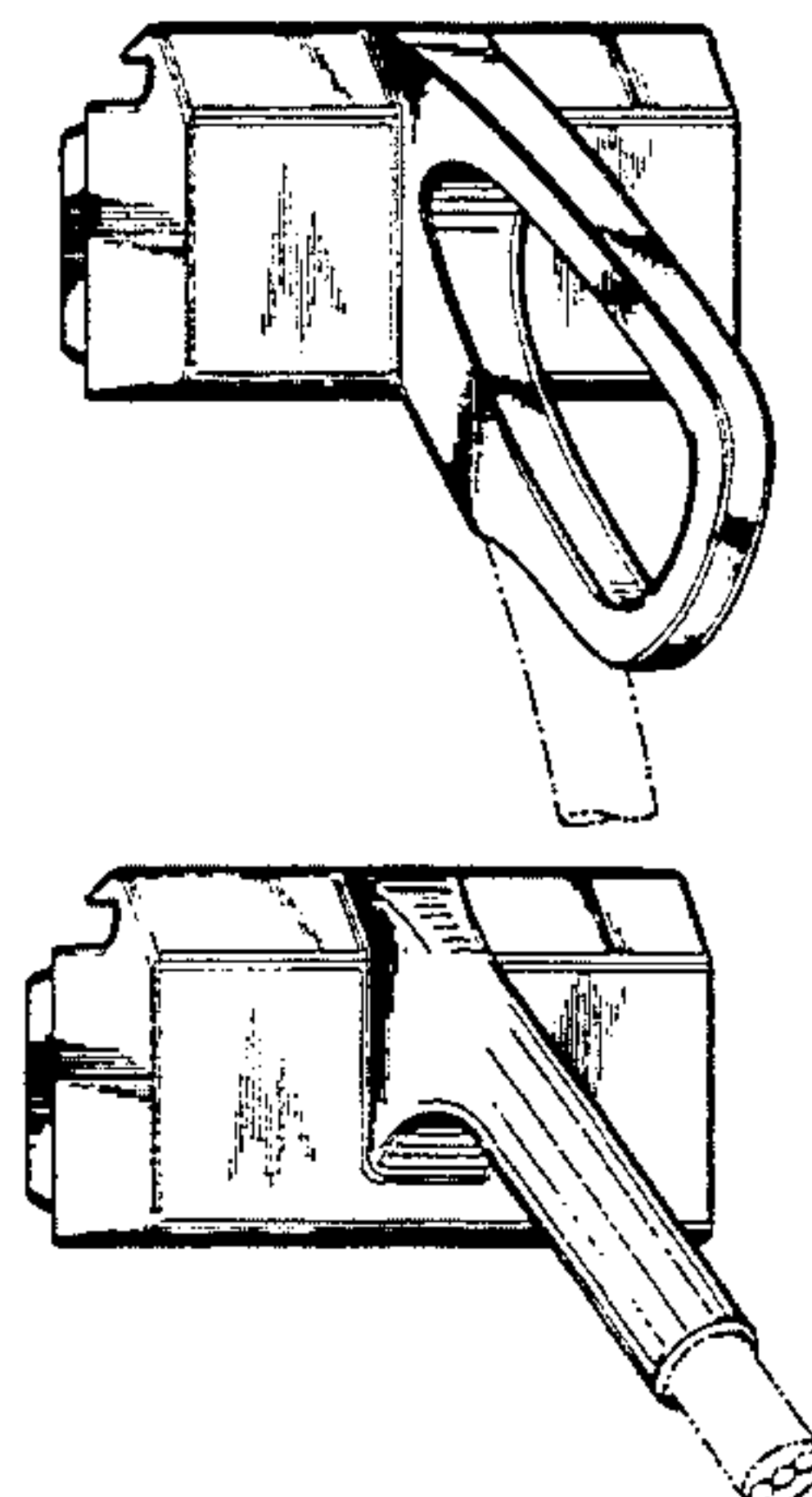

**DESCRIPTION**

FIG. 12 is a rear elevational view of the dead front electrical connector for charging electric cars shown in FIGS. 8-11;

FIG. 13 is a top plan view of the dead front electrical connector for charging electric cars shown in FIGS. 8-12;

FIG. 14 is a bottom plan view of the dead front electrical connector for charging electric cars shown in FIGS. 8-13;

FIG. 15 is a rear perspective view of a dead front electrical connector for charging electric cars showing a third embodiment of my new design which is substantially identical to the first embodiment except for a modified handle;

FIG. 16 is a rear perspective view of a dead front electrical connector for charging electric cars shown in FIG. 15 viewed along line 16-16;

FIG. 17 is a rear perspective view of a dead front electrical connector for charging electric cars showing a fourth embodiment of my new design which is substantially identical to the second embodiment except for a modified handle;

FIG. 18 is a rear perspective view of a dead front electrical connector for charging electric cars shown in FIG. 17 viewed along line 18-18; and,

FIG. 19 is a front perspective view of a dead front electrical connector for charging electric cars showing a fifth embodiment of my new design which is substantially identical to the first embodiment except for the appearance of the top edge.



FIG. 2

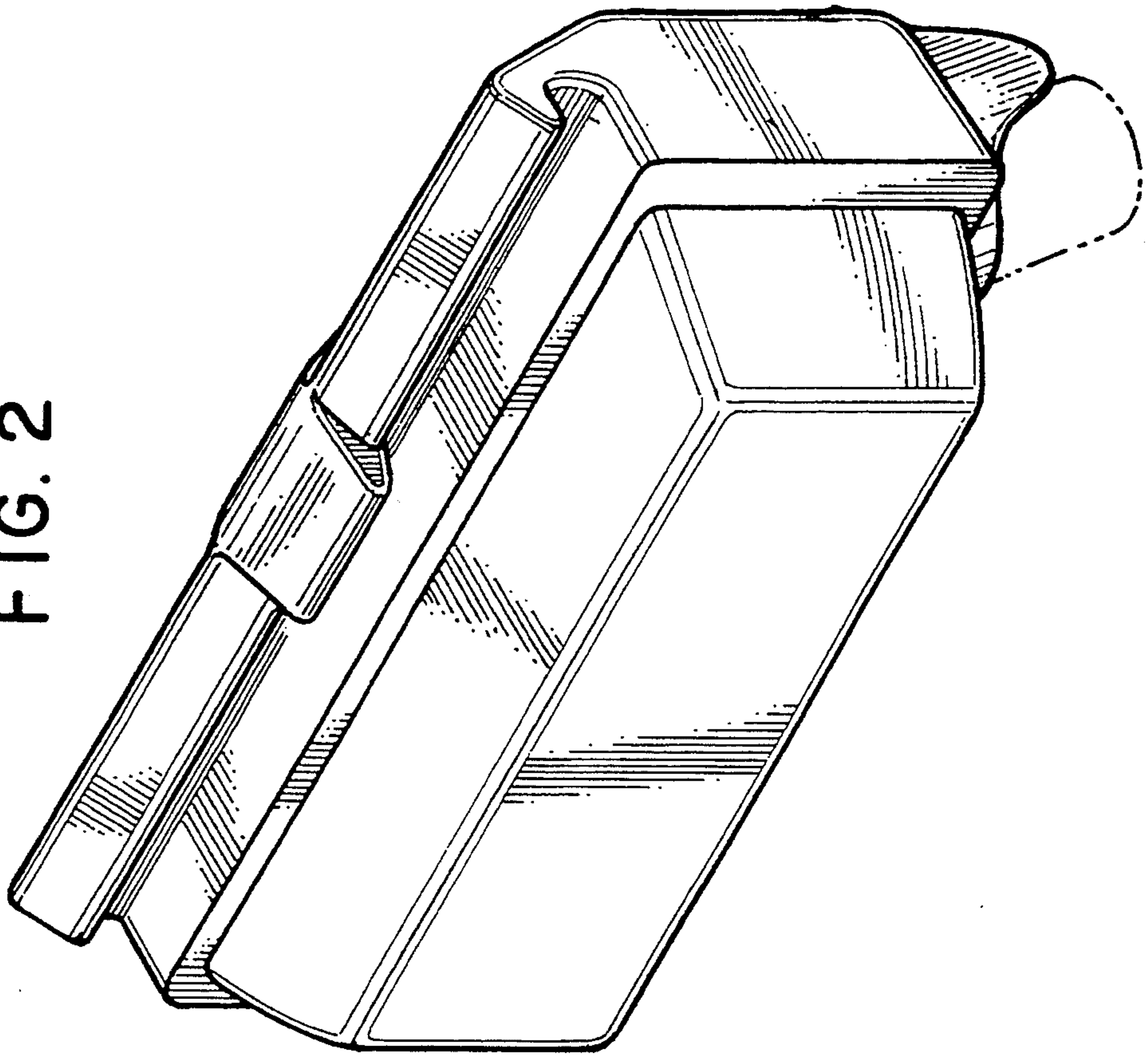

FIG. 1

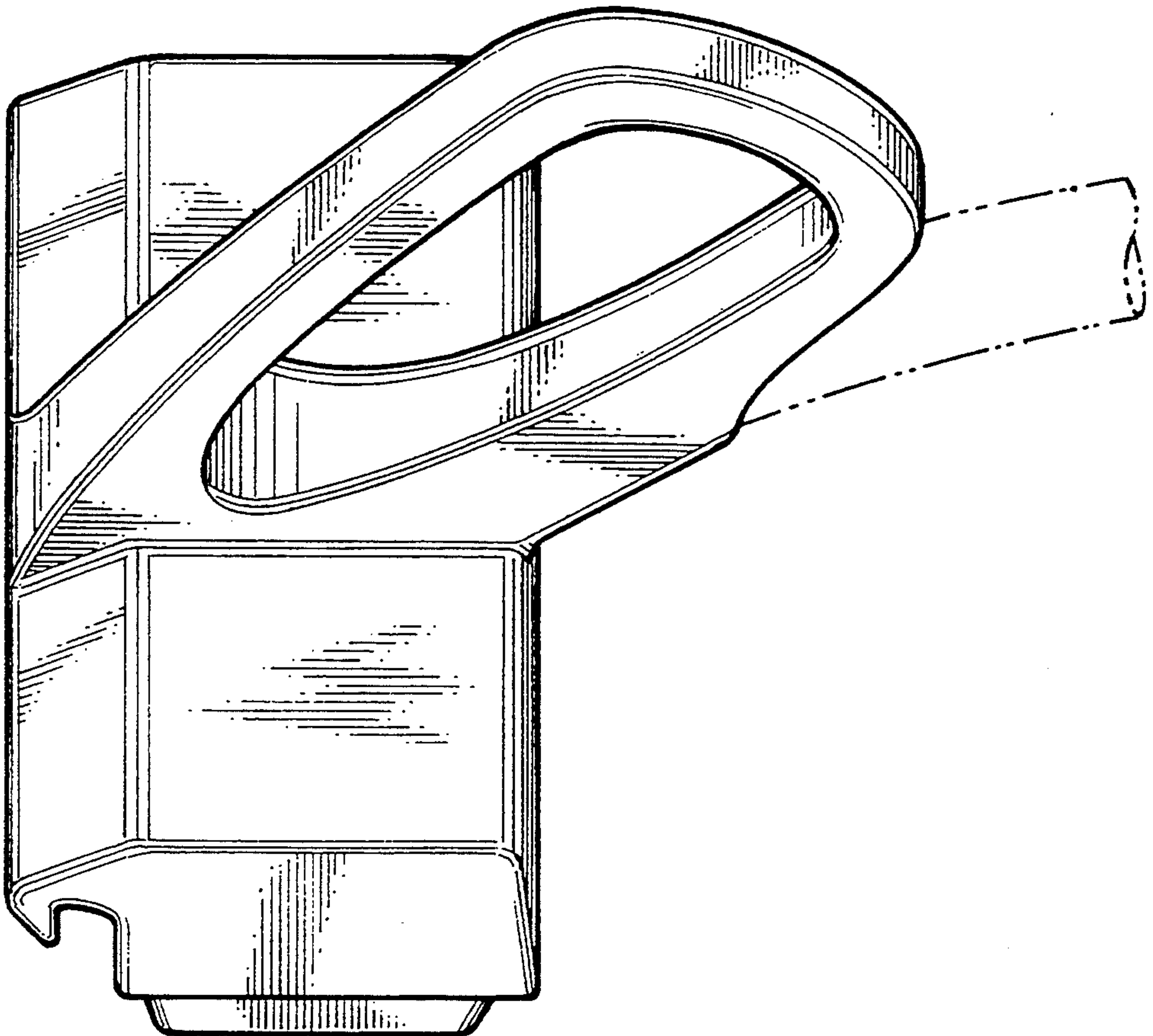

FIG. 3

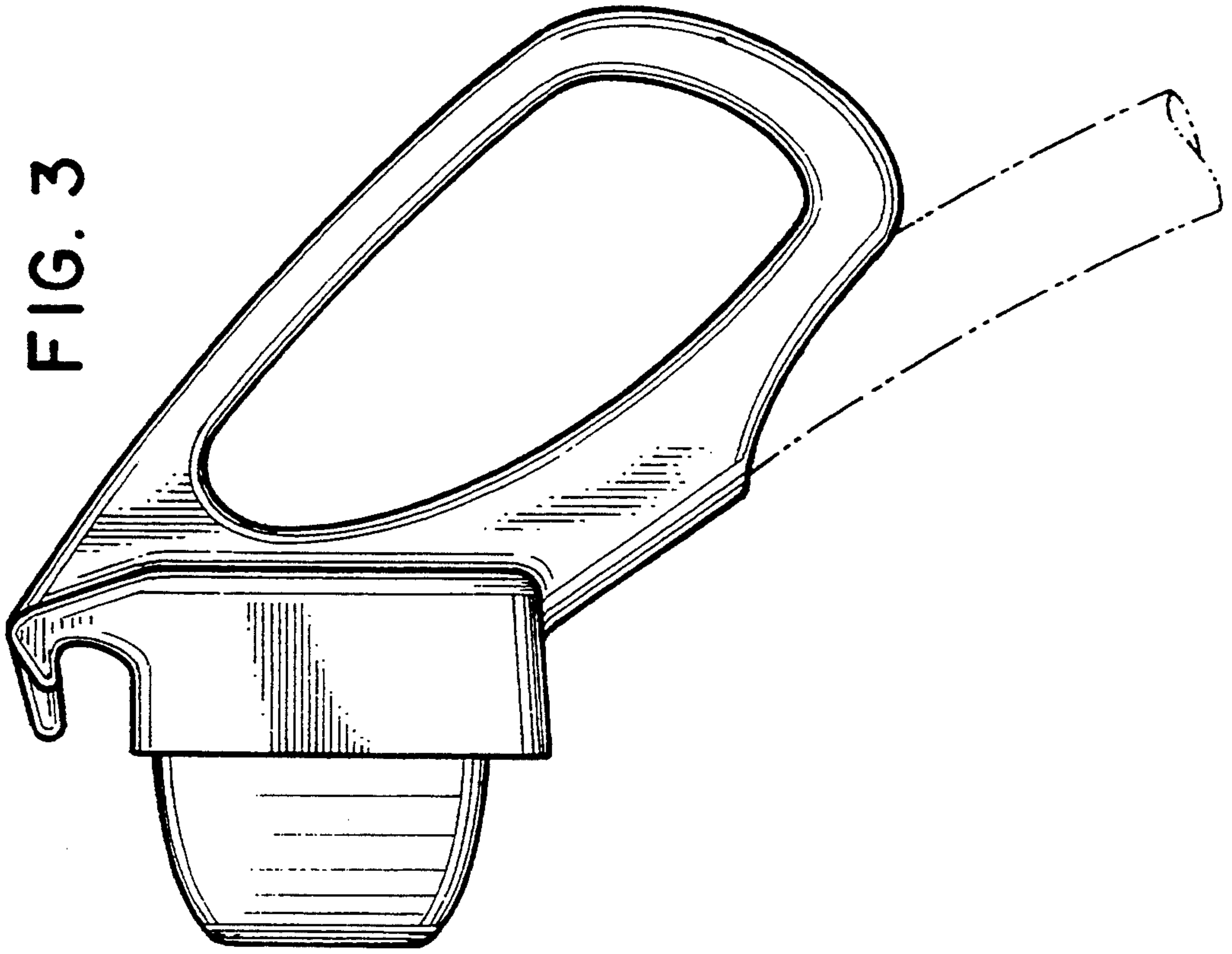

FIG. 4

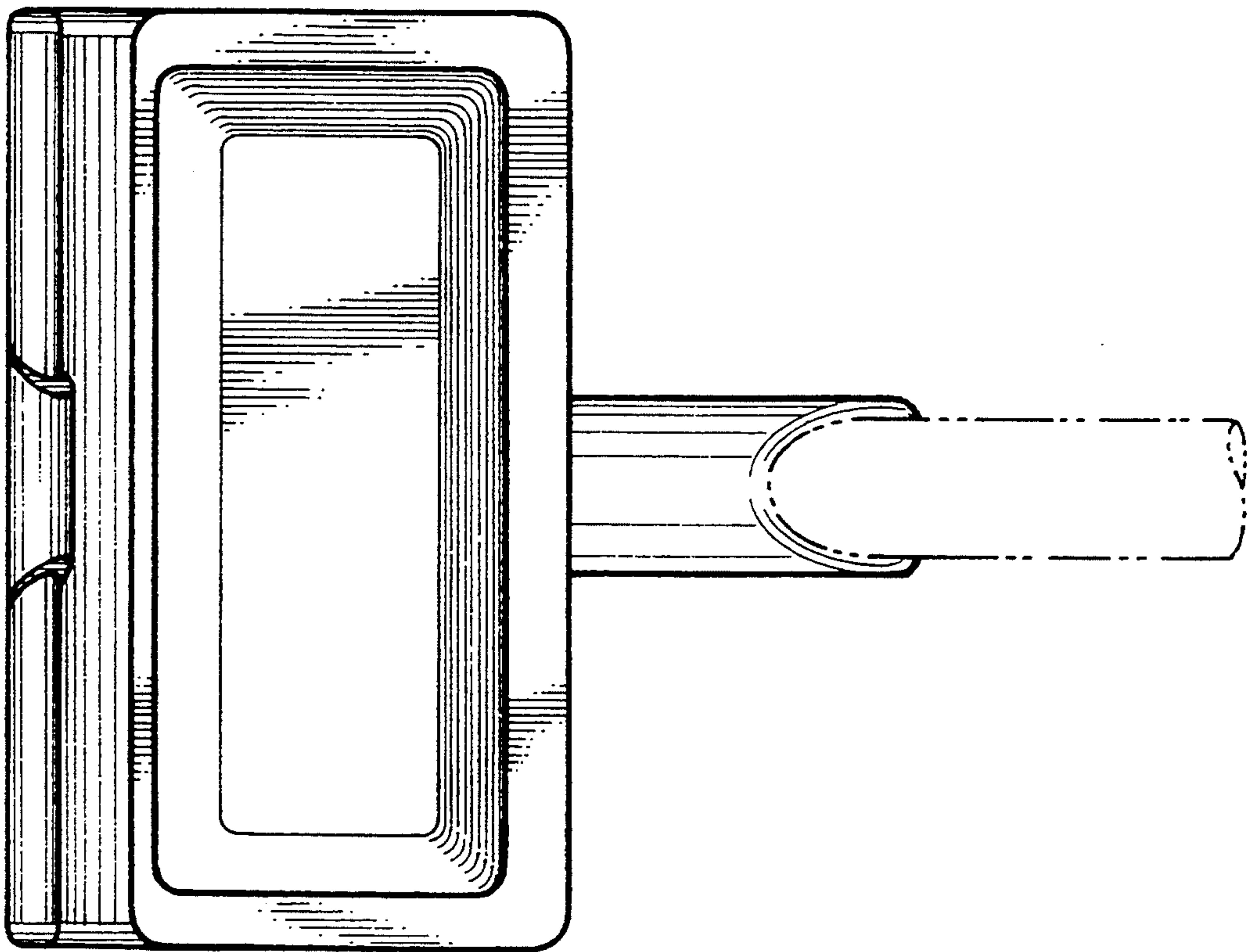

FIG. 5

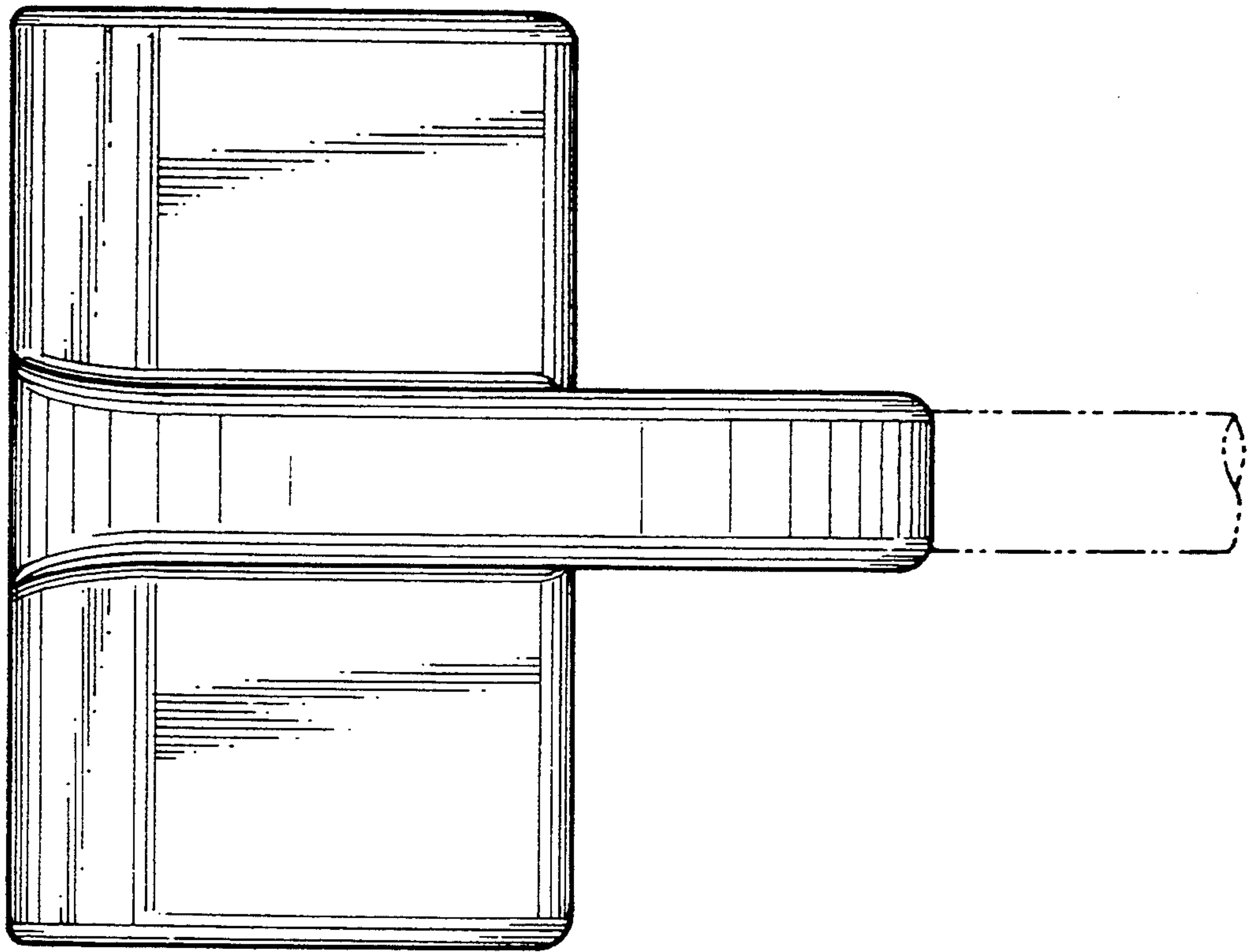

FIG. 7

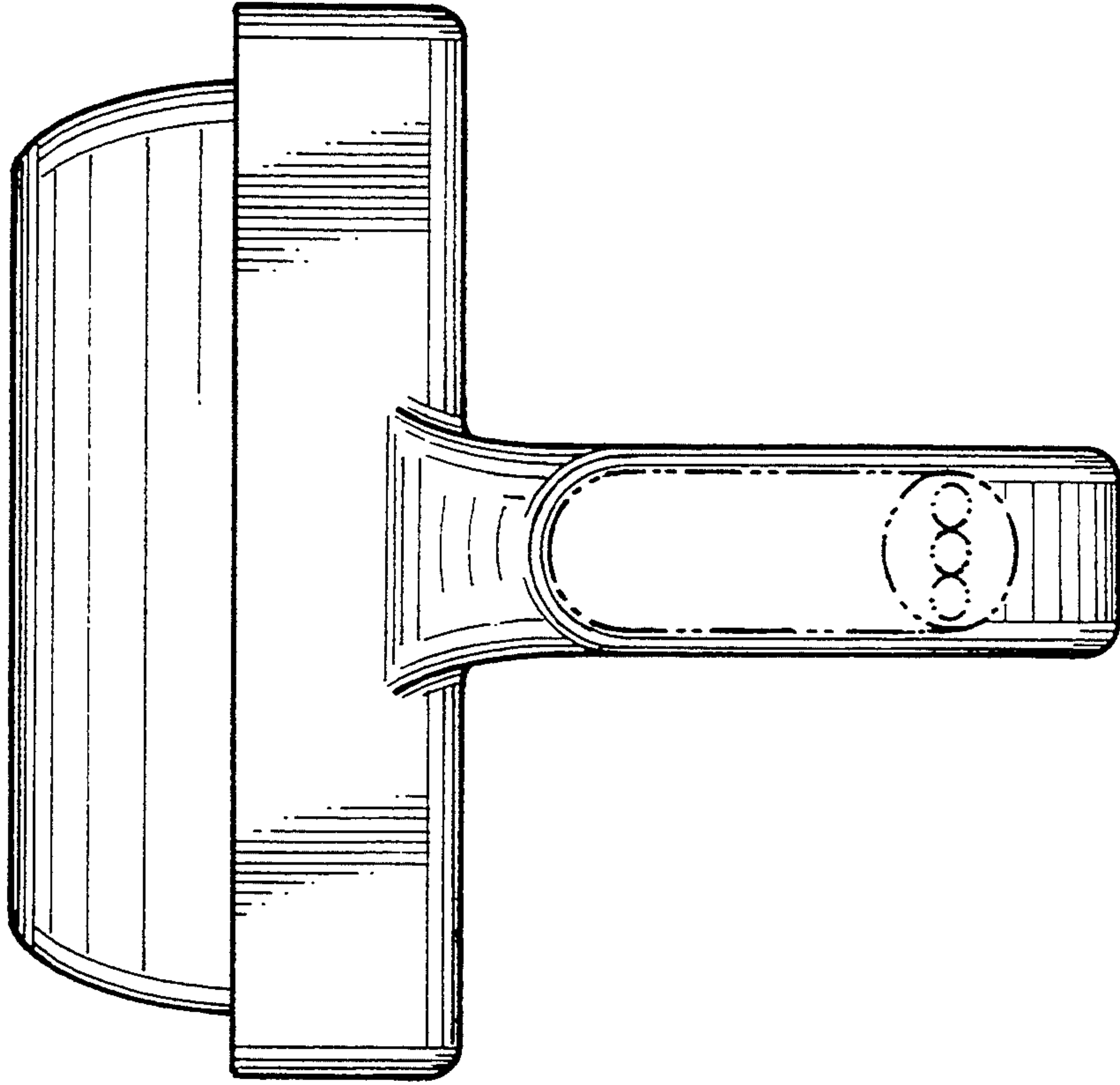

FIG. 6

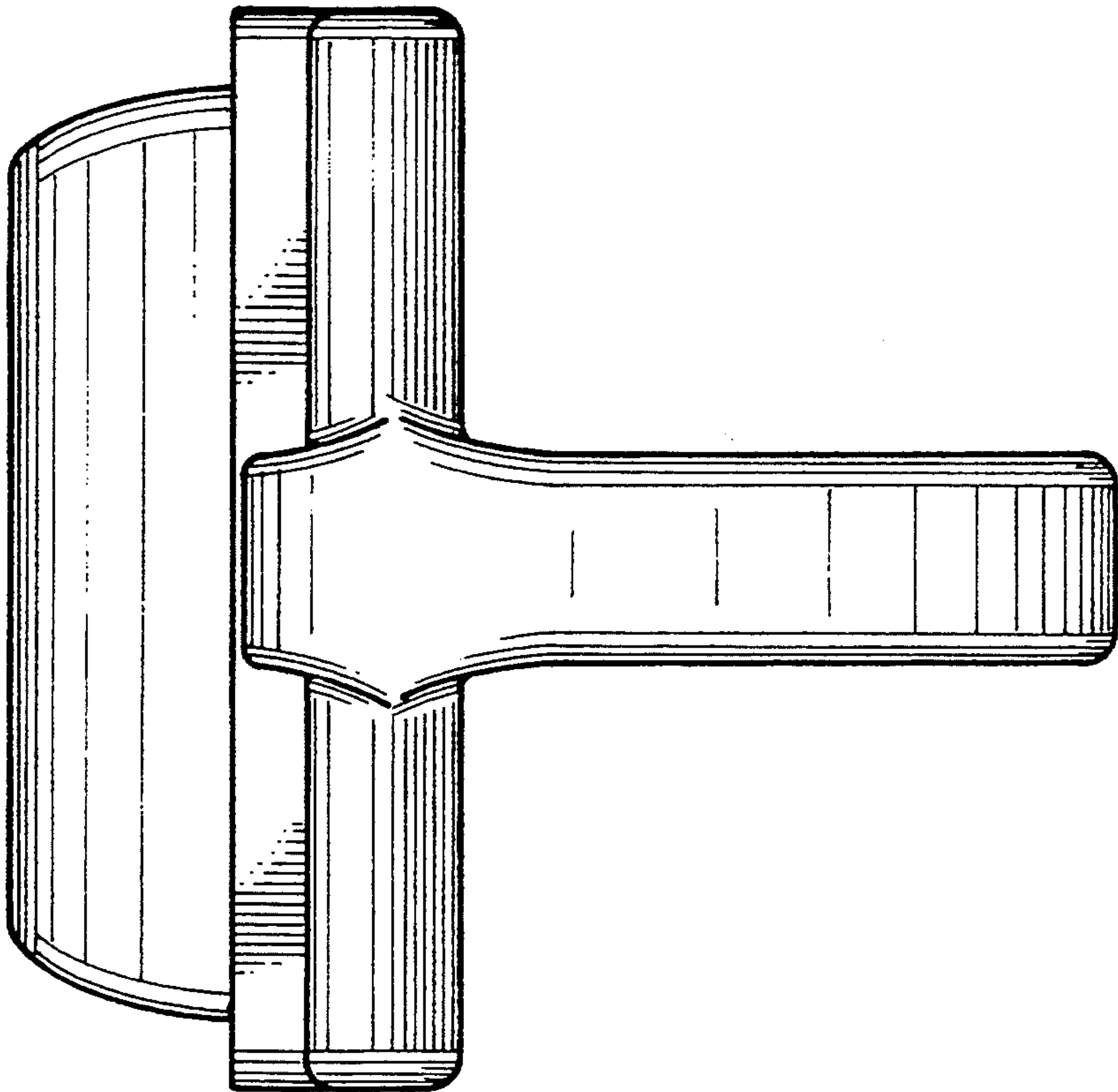



FIG. 9

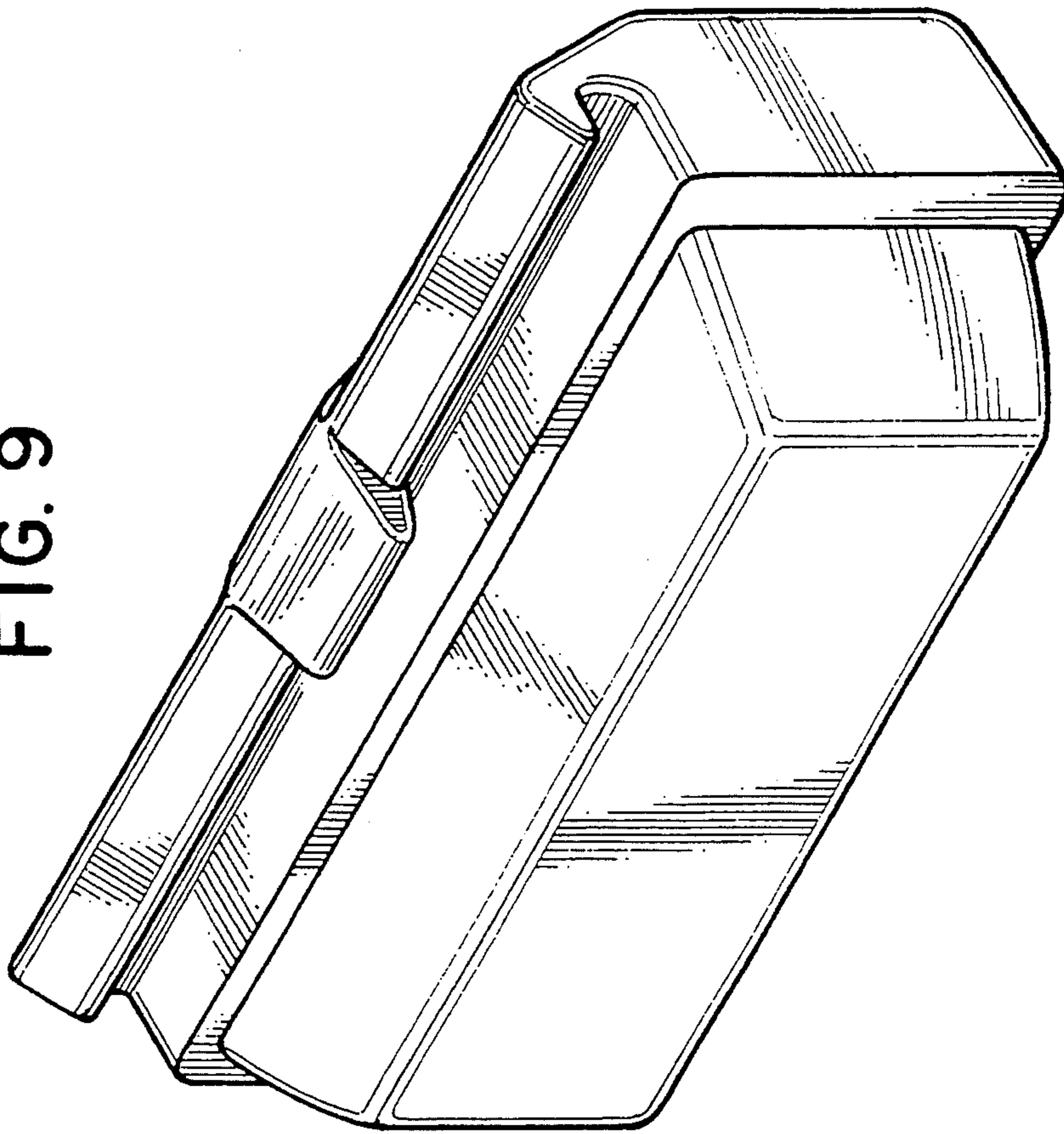

FIG. 8

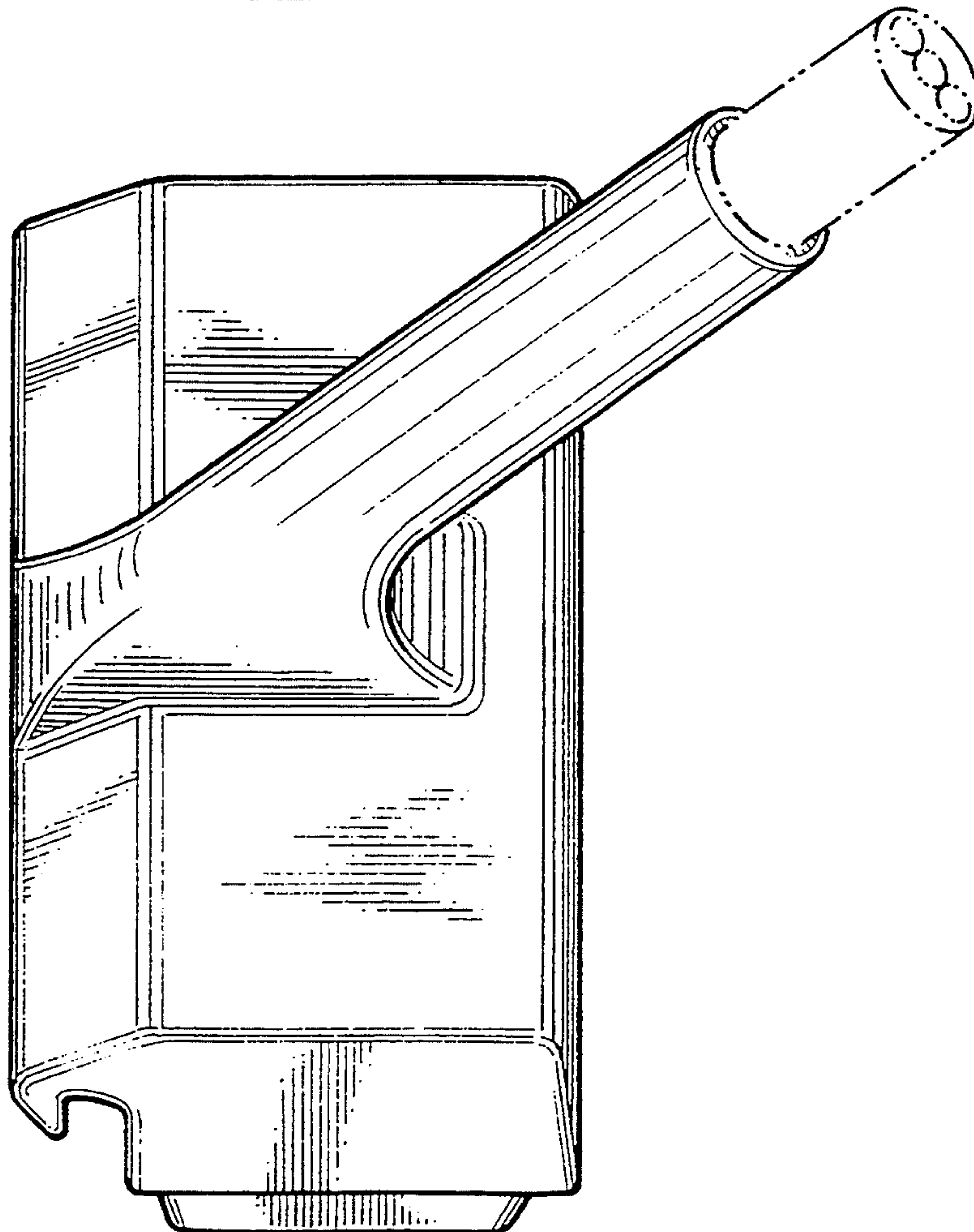

FIG. 10

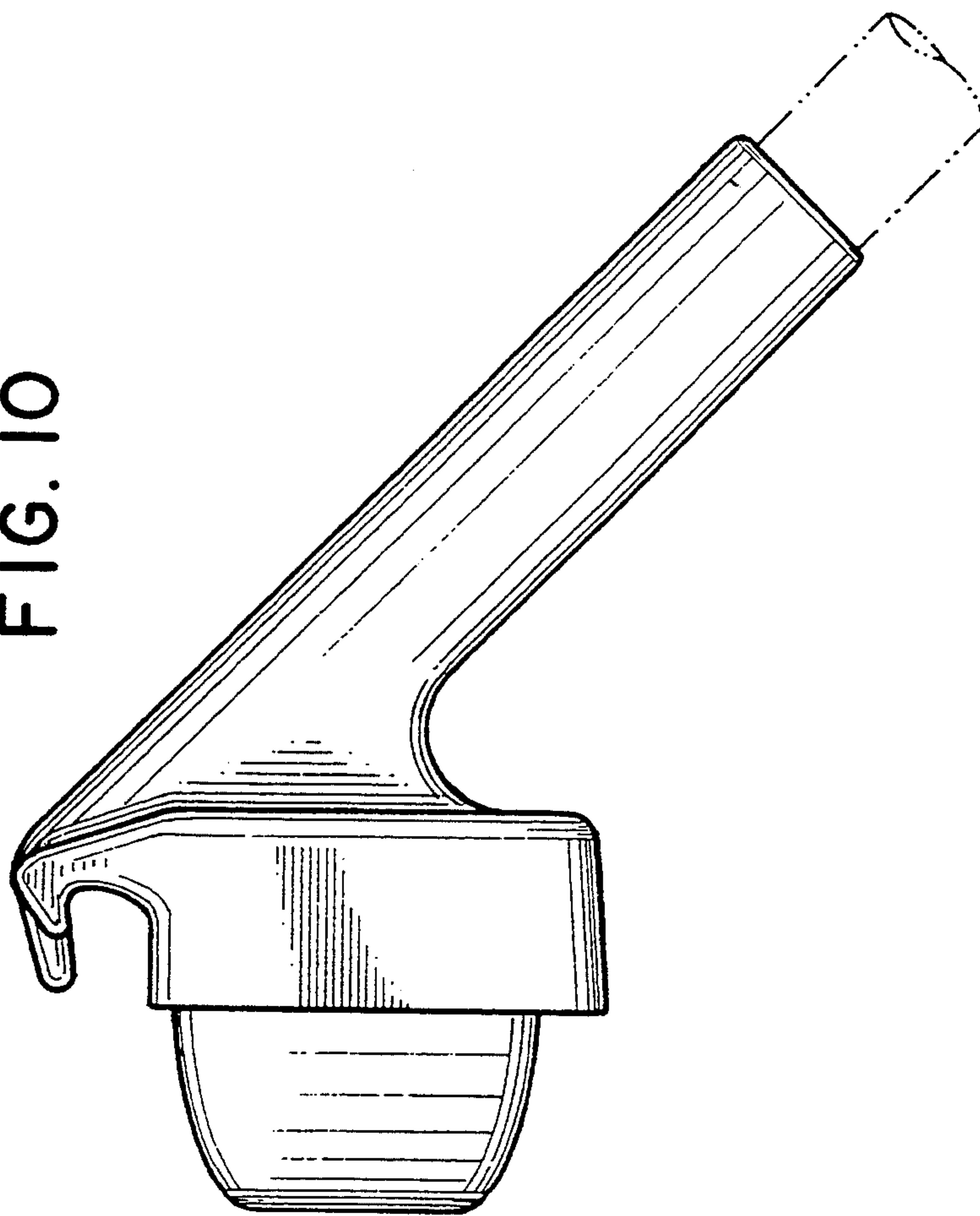

FIG. 11

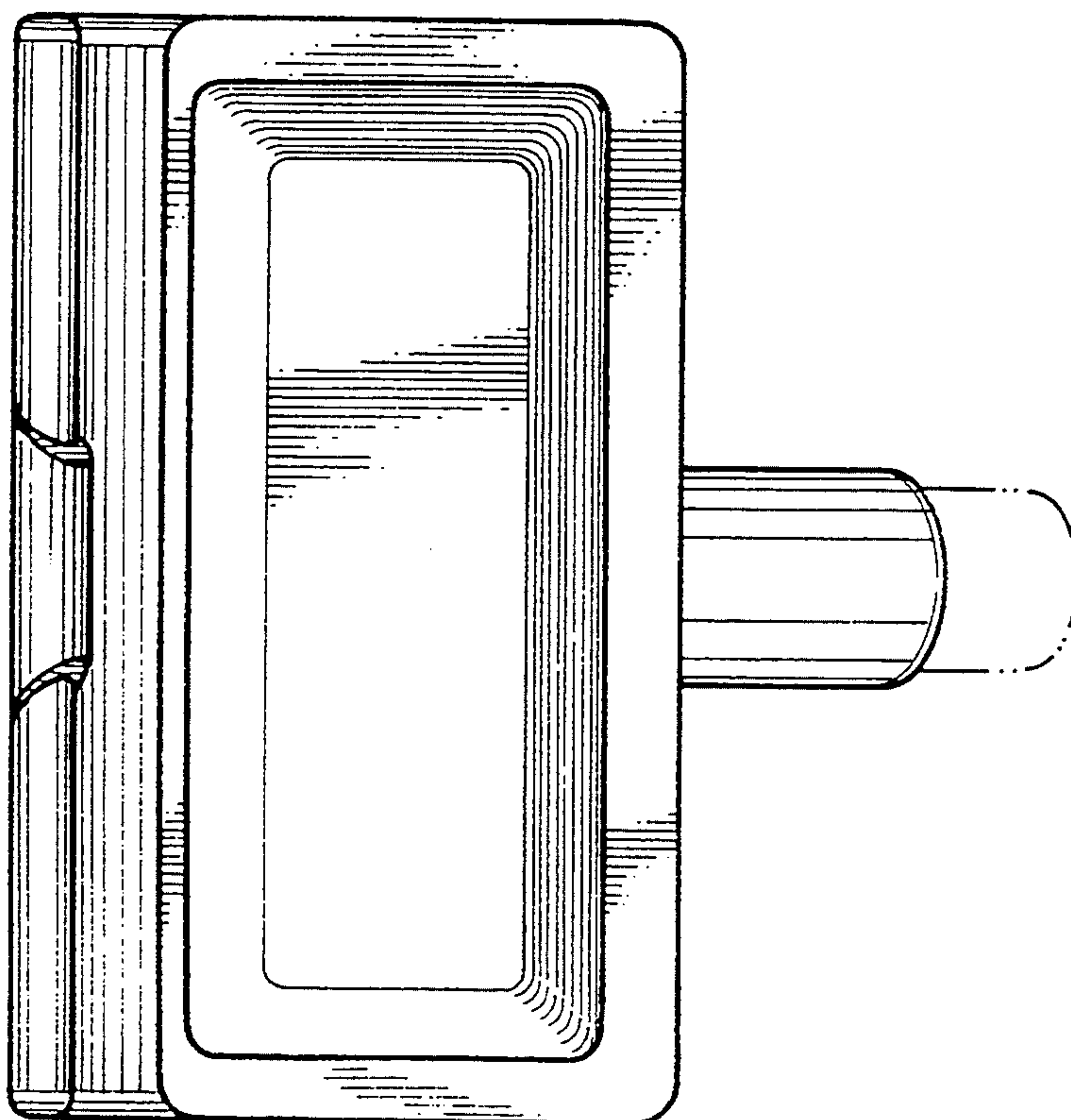



FIG. 12

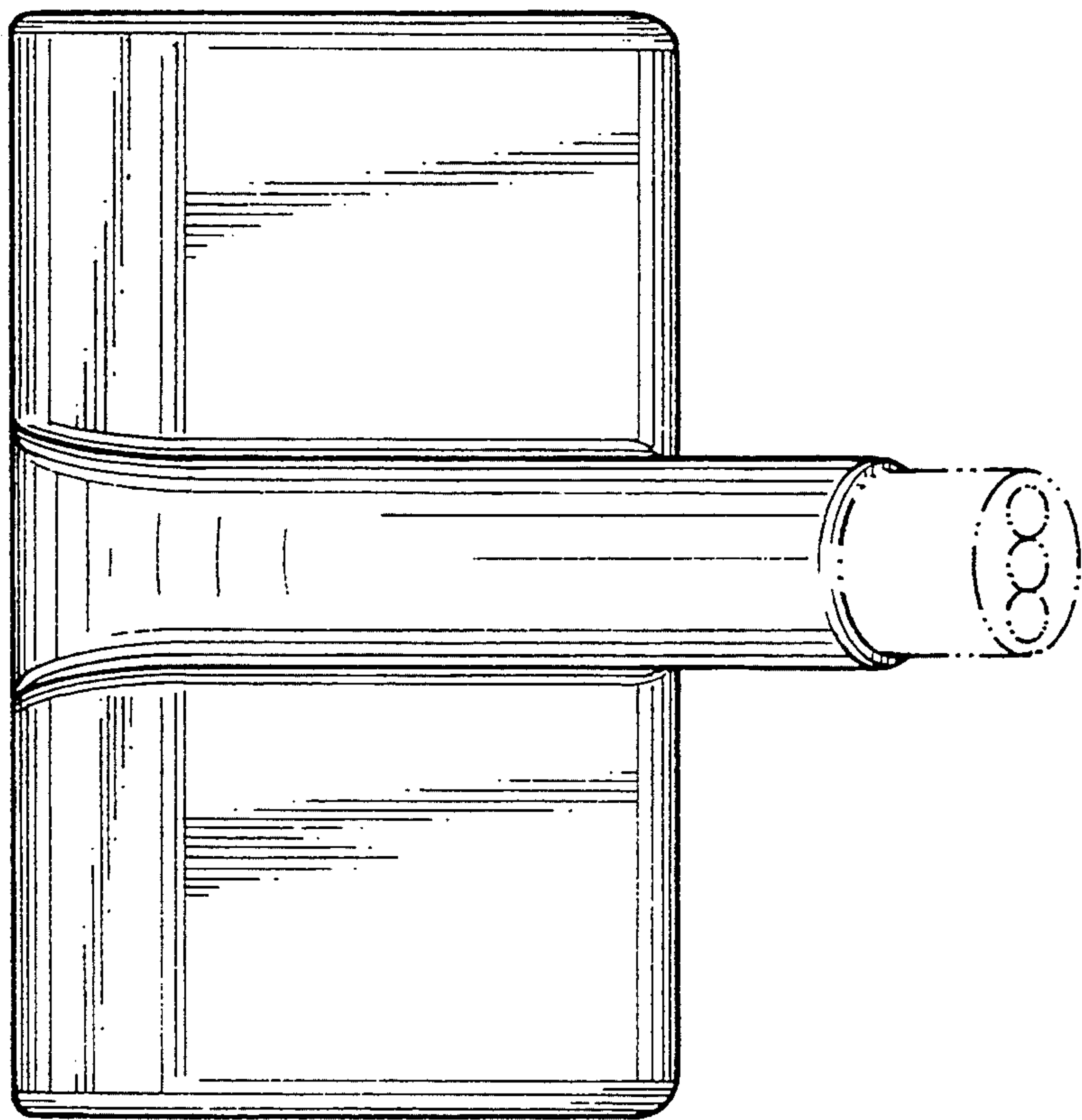

FIG. 14

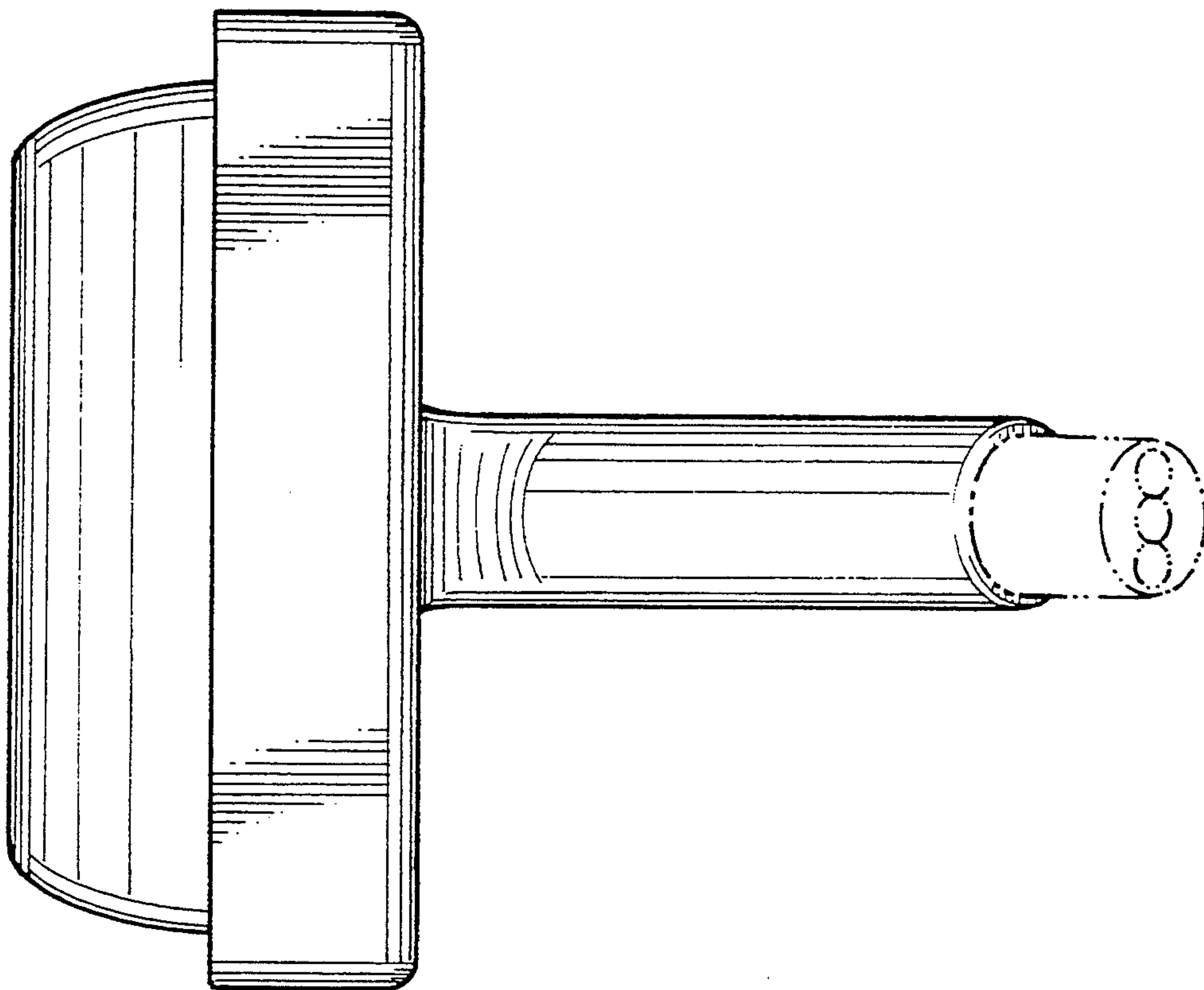

FIG. 13

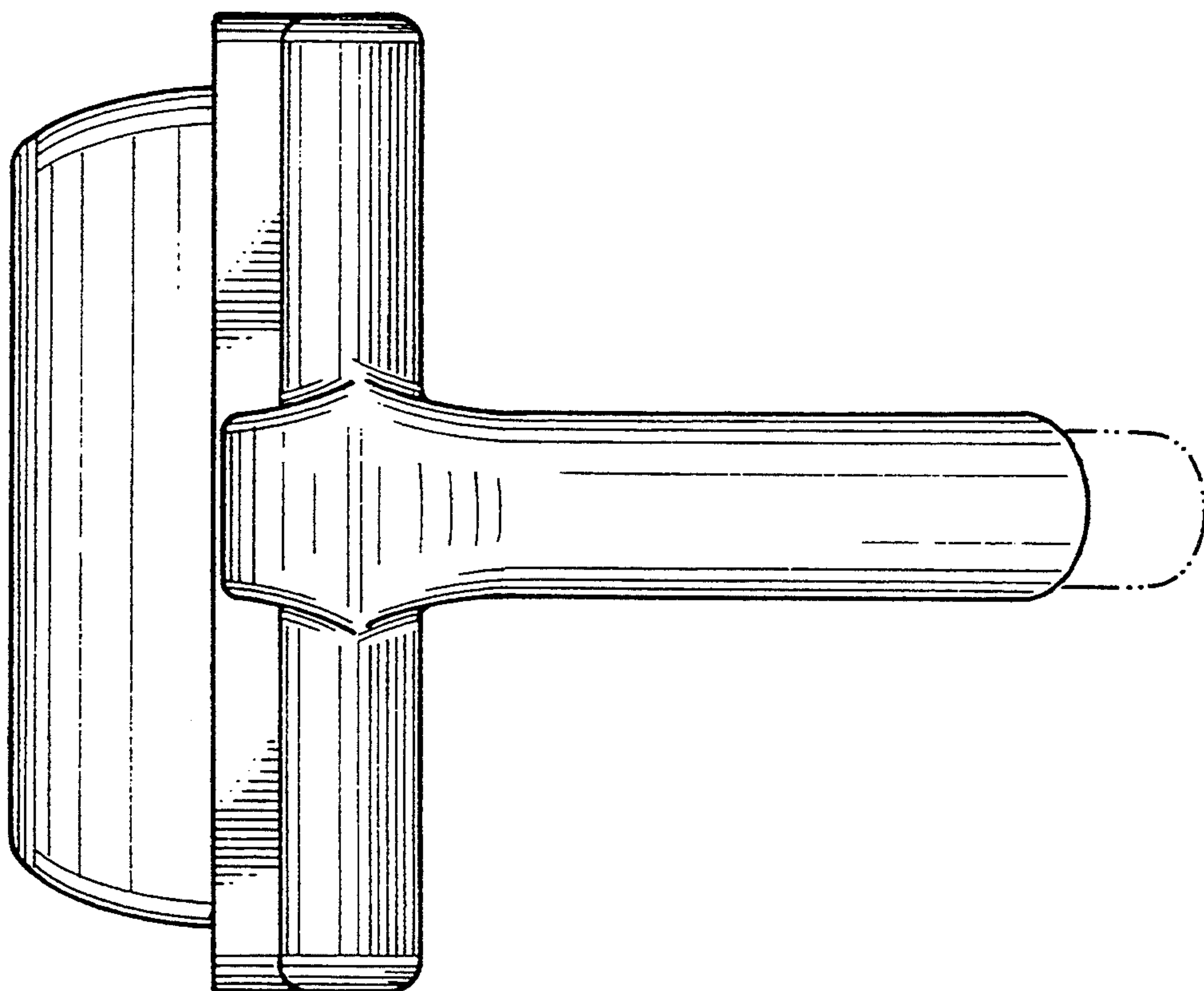

FIG. 16

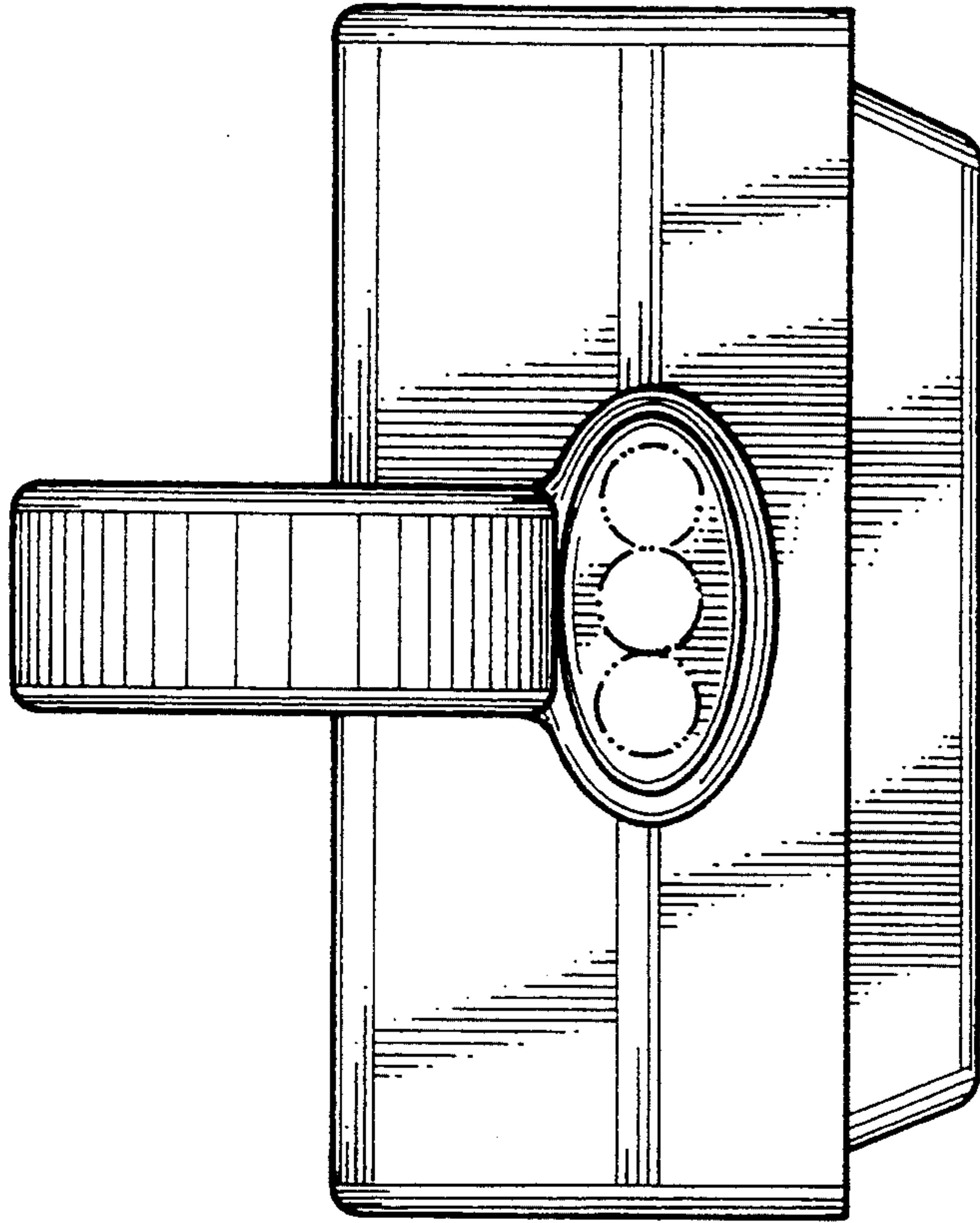

FIG. 15

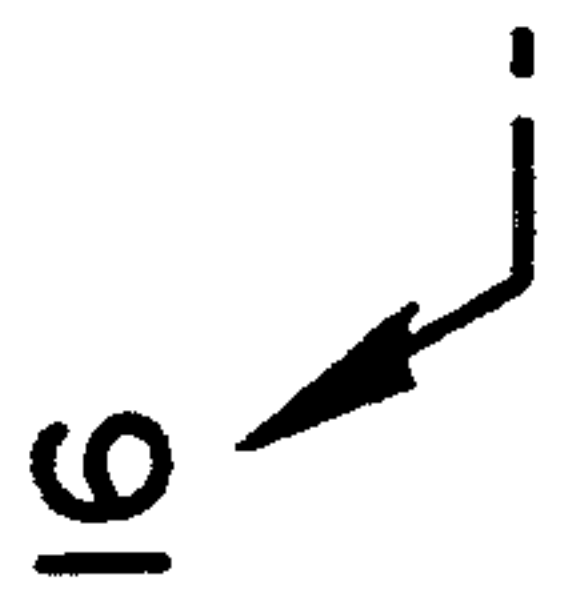
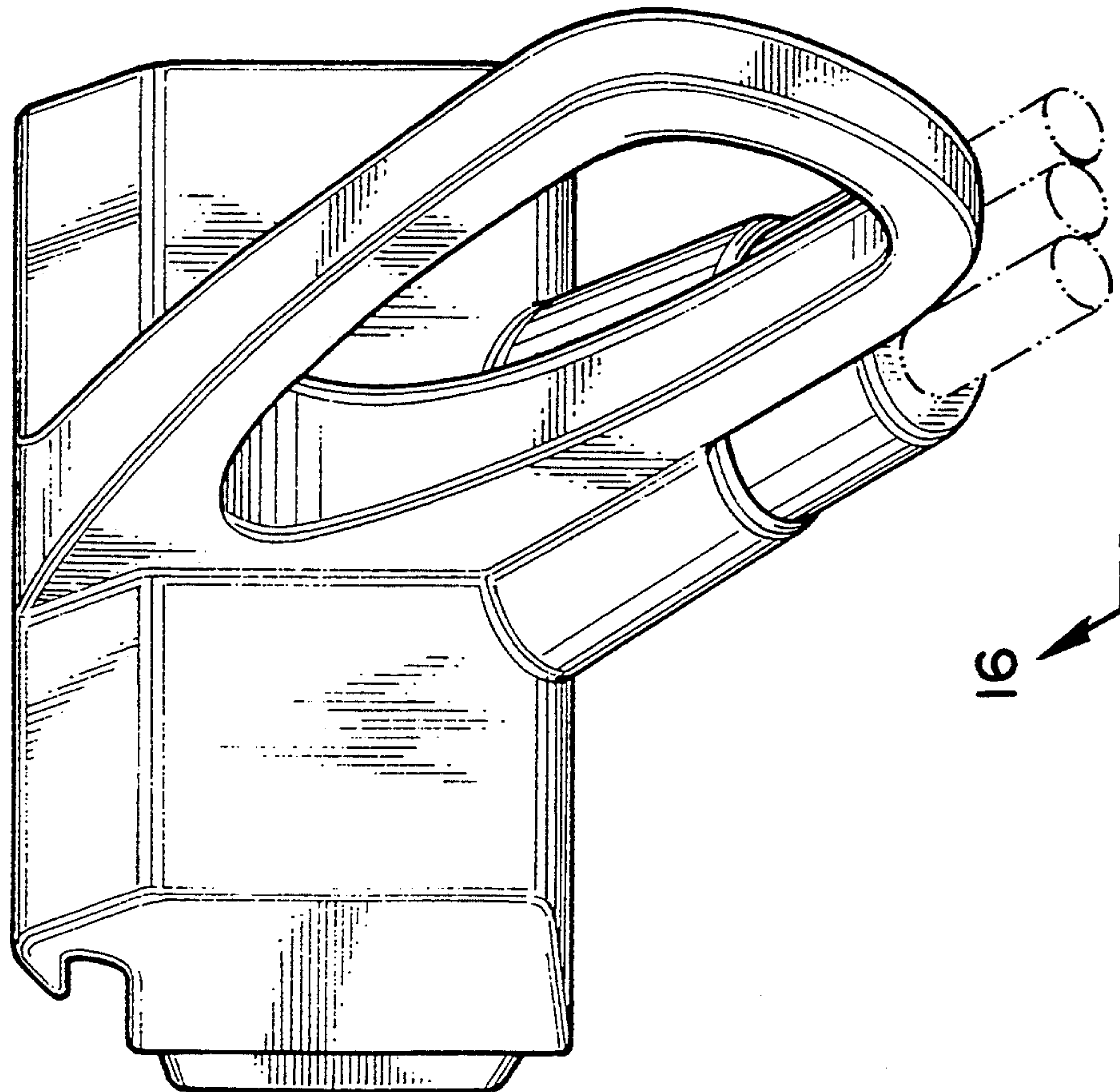



FIG. 18

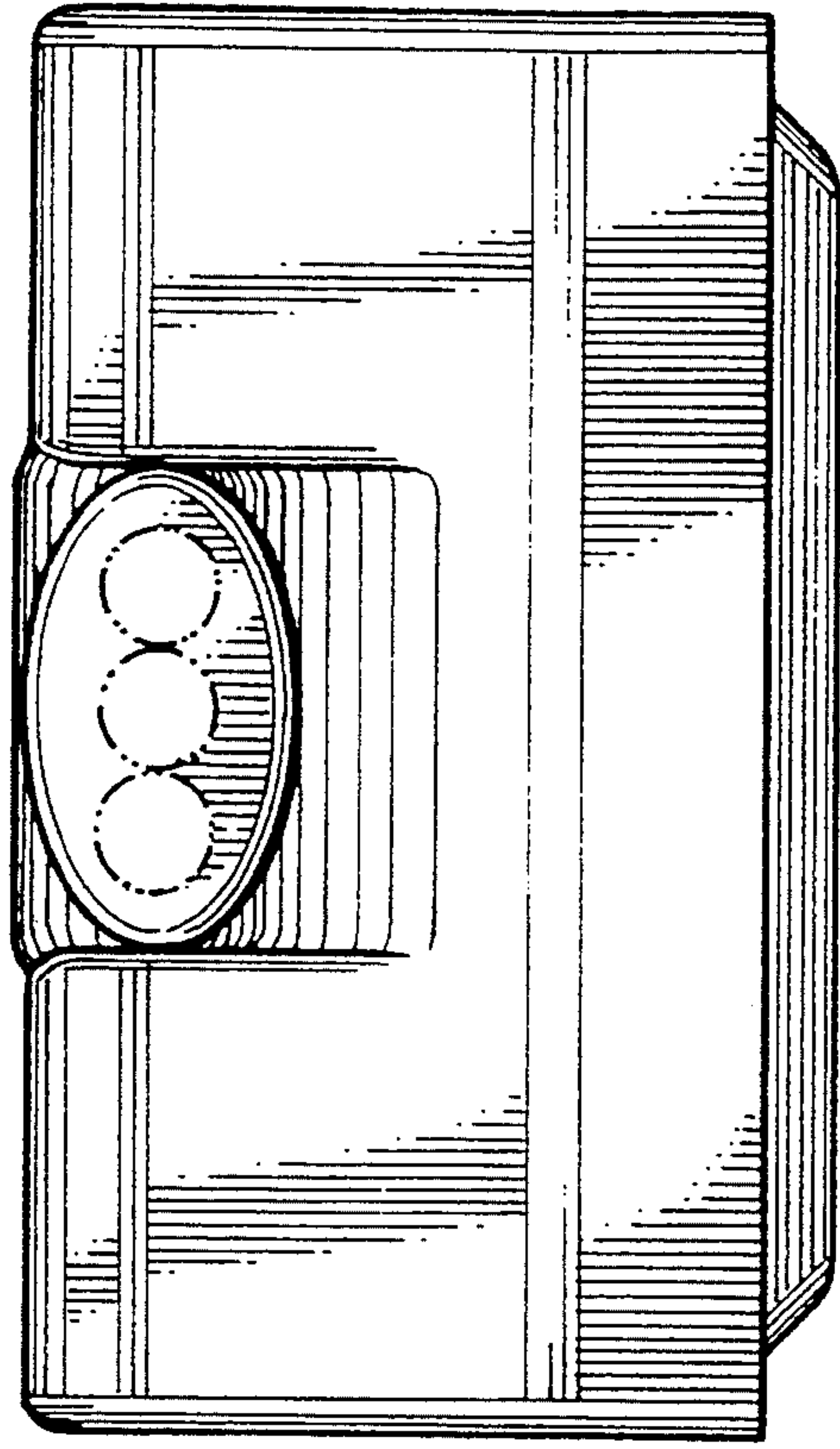
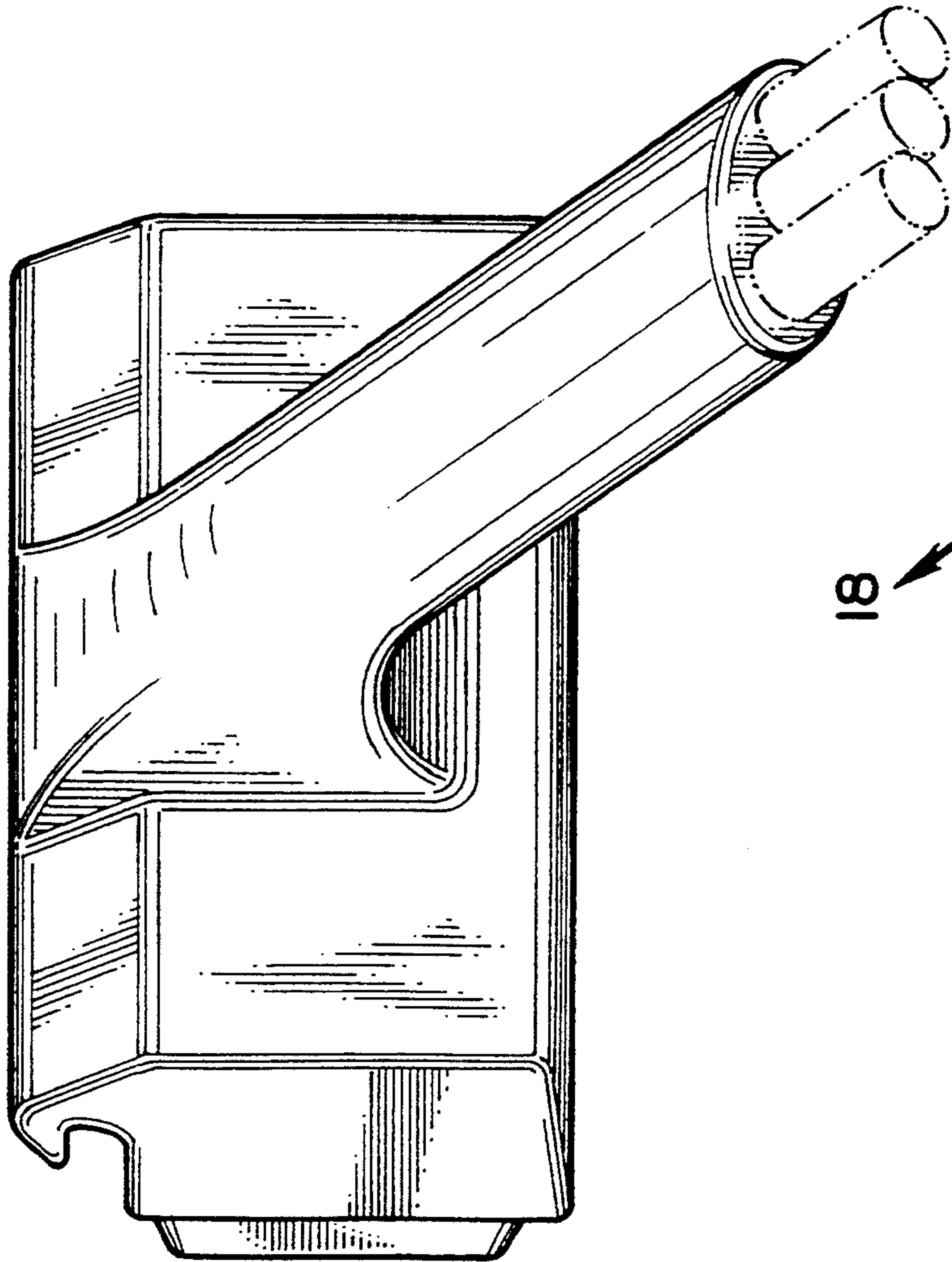

FIG. 17



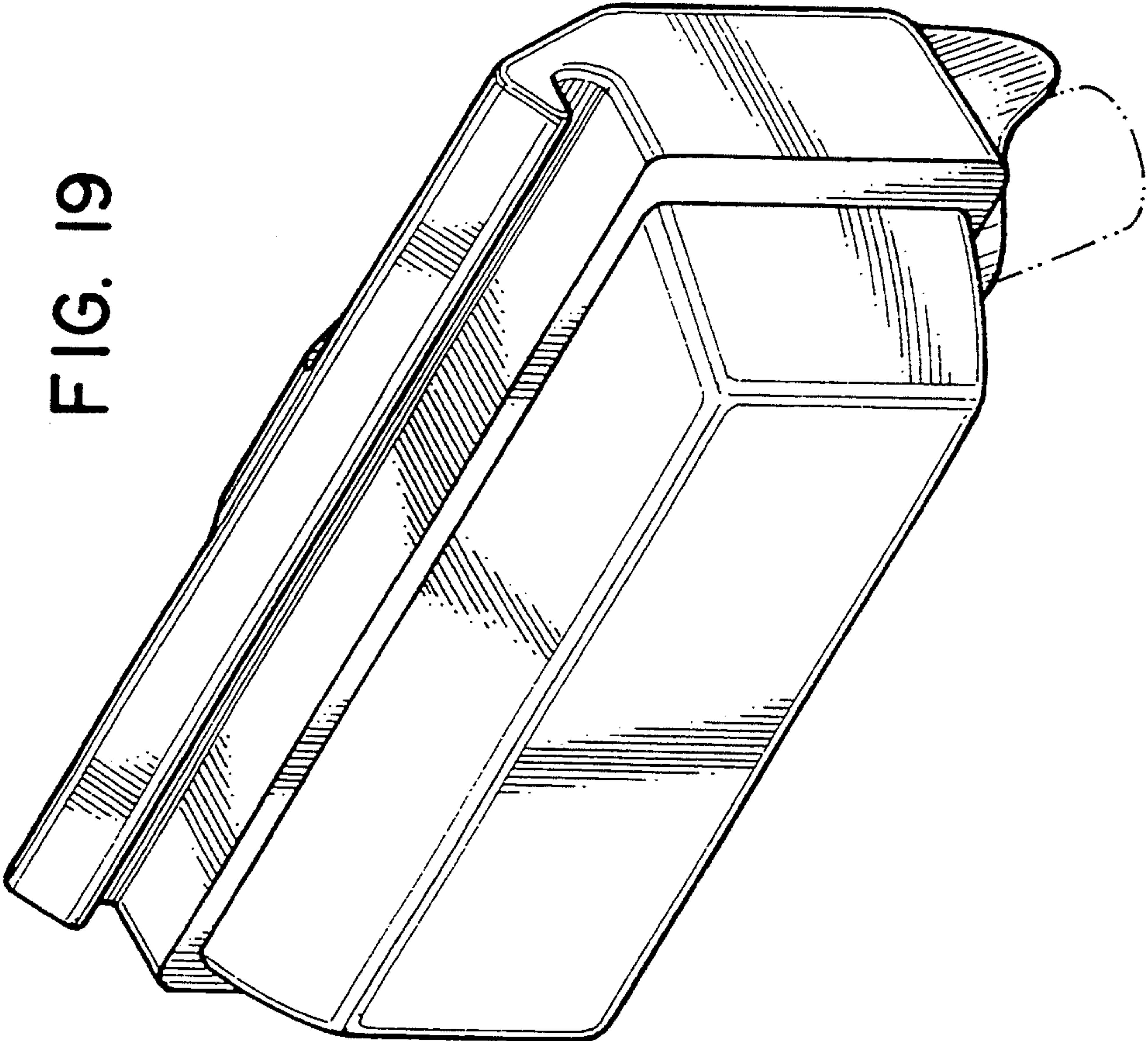

FIG. 19