



US00D350274S

United States Patent [19]

[11] Patent Number: **Des. 350,274**

Baker

[45] Date of Patent: **** Sep. 6, 1994**

[54] ANTI-THEFT STEERING-WHEEL RESTRICTOR

FOREIGN PATENT DOCUMENTS

[76] Inventor: **Franklin W. Baker**, 1502½ N. LaBrea, Inglewood, Calif. 90302

2134057A 8/1984 United Kingdom .

Primary Examiner—Brian N. Vinson
Attorney, Agent, or Firm—Albert O. Cota

[**] Term: **14 Years**

[57] CLAIM

[21] Appl. No.: **9,685**

The ornamental design for an anti-theft steering-wheel restrictor, as shown and described.

[22] Filed: **Jun. 21, 1993**

DESCRIPTION

[52] U.S. Cl. **D8/331**

[58] Field of Search **D8/330-331, D8/333, 339, 341; 70/14, 233, 237-238, 245, 247, 252**

FIG. 1 is a front elevational view of an anti-theft steering-wheel restrictor showing my new design as would be attached to a vehicle steering wheel;

FIG. 2 is a top plan view thereof;

FIG. 3 is a bottom plan view thereof;

FIG. 4 is a front elevational view thereof;

FIG. 5 is a back elevational view thereof;

FIG. 6 is a right side elevational view thereof; and,

FIG. 7 is a left side elevational view thereof.

The wheel depicted by means of broken lines in FIG. 1, is shown for illustrative purposes only and forms no part of the claimed design.

[56] References Cited

U.S. PATENT DOCUMENTS

D. 316,026	4/1991	Fuller	D8/331
D. 317,708	6/1991	Fuller	D8/331
D. 330,844	11/1992	Chang	D8/331
D. 331,870	12/1992	Fuller	D8/331
5,095,723	3/1992	Lin	70/238 X

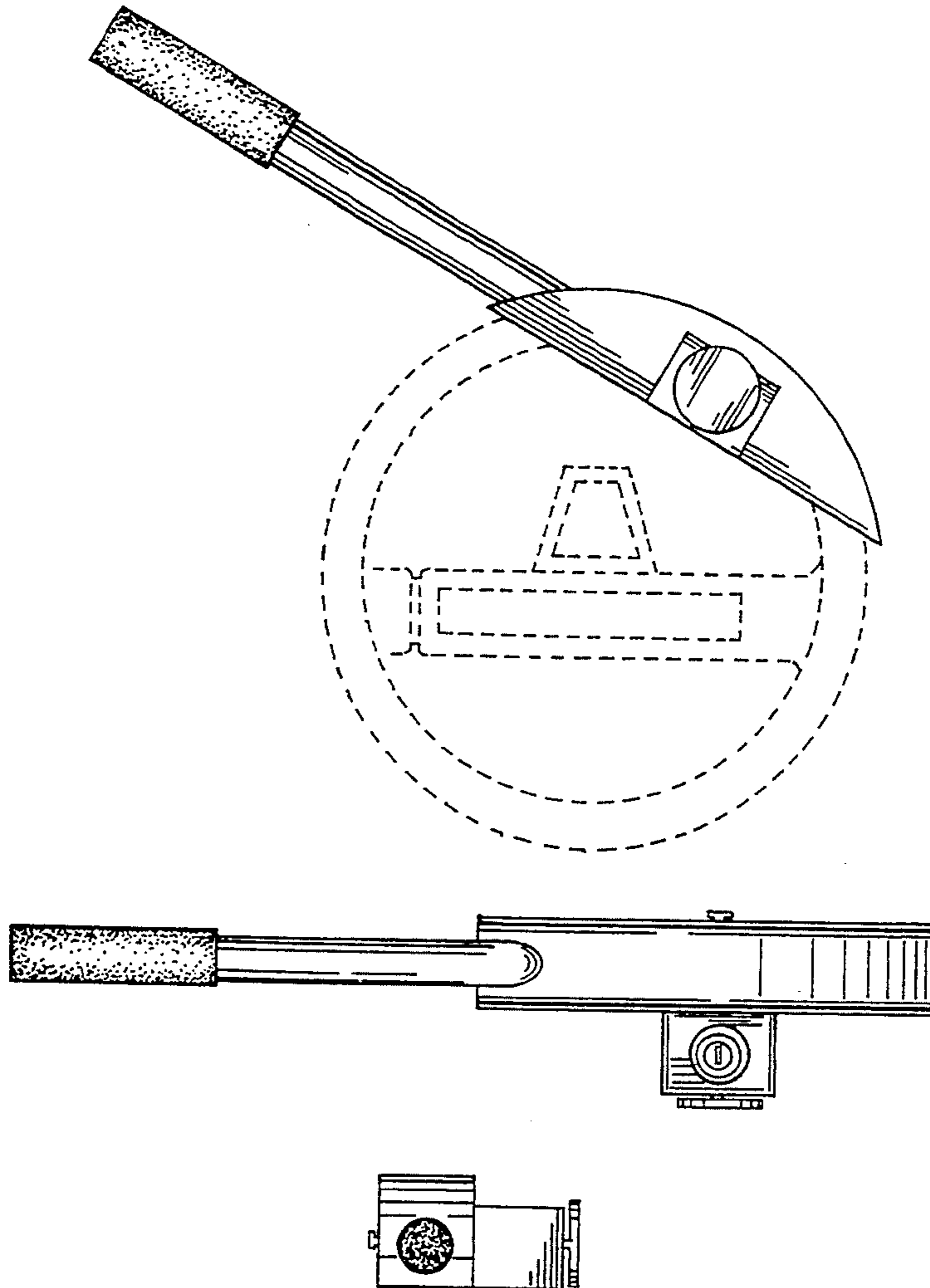

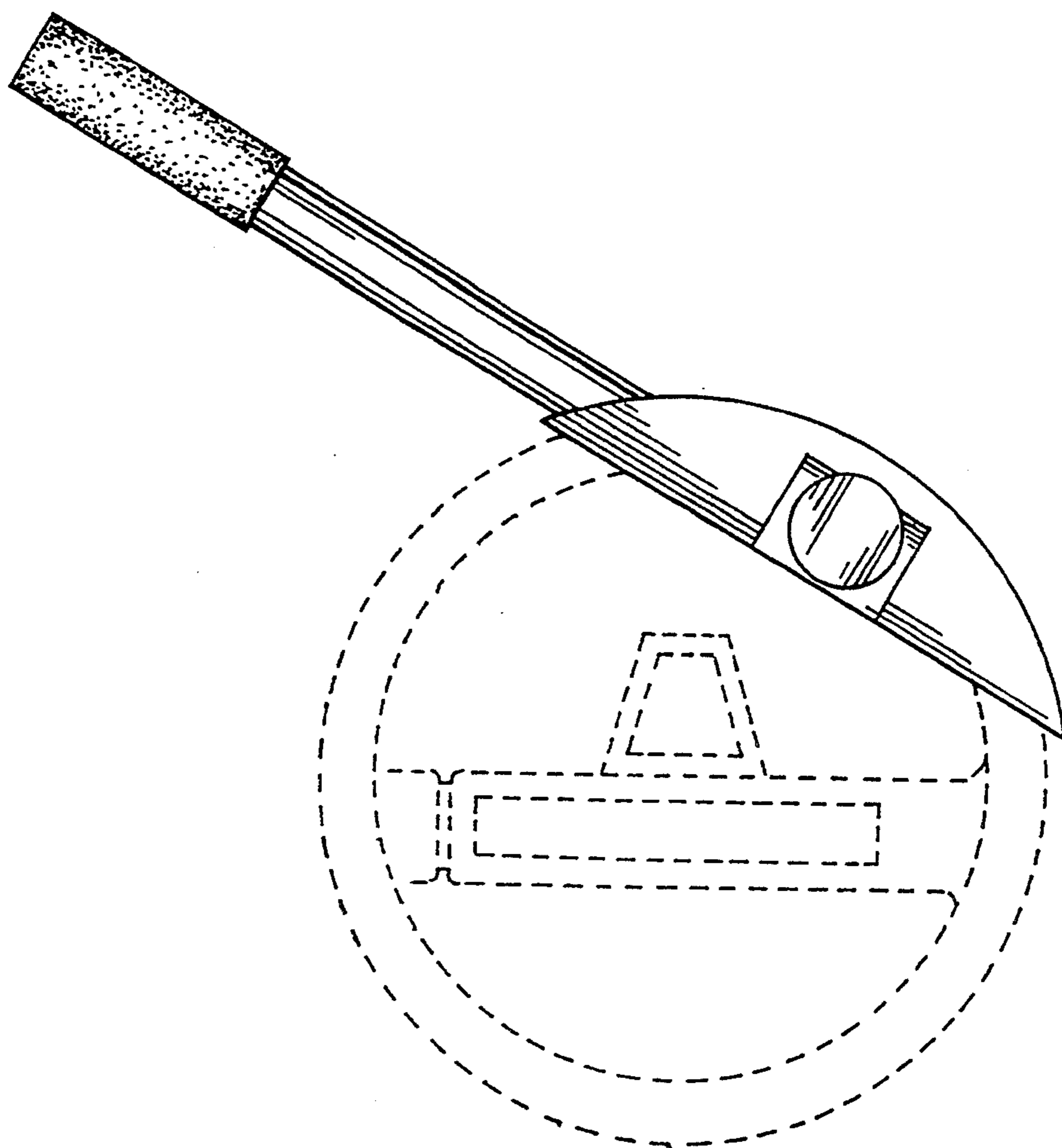

Fig. 1.

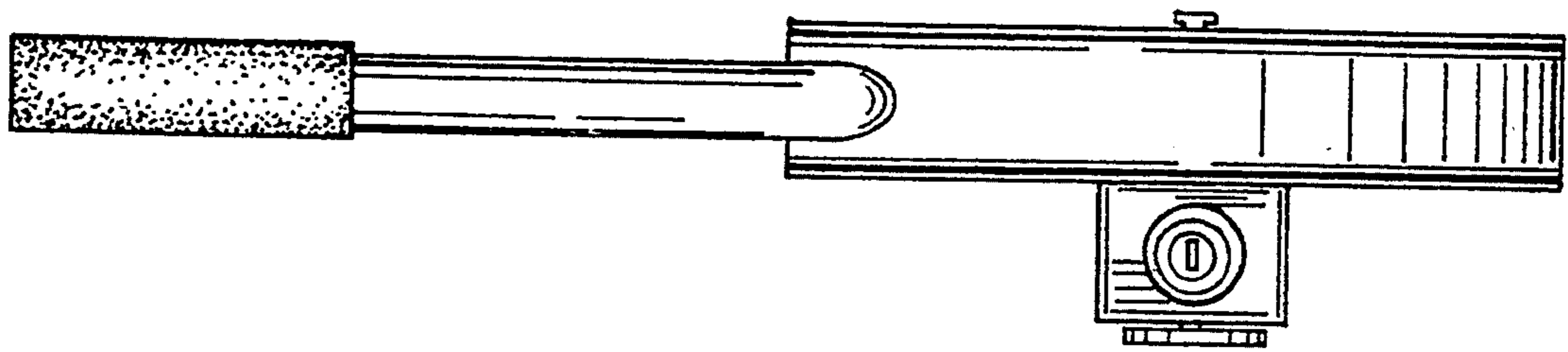

Fig. 2.

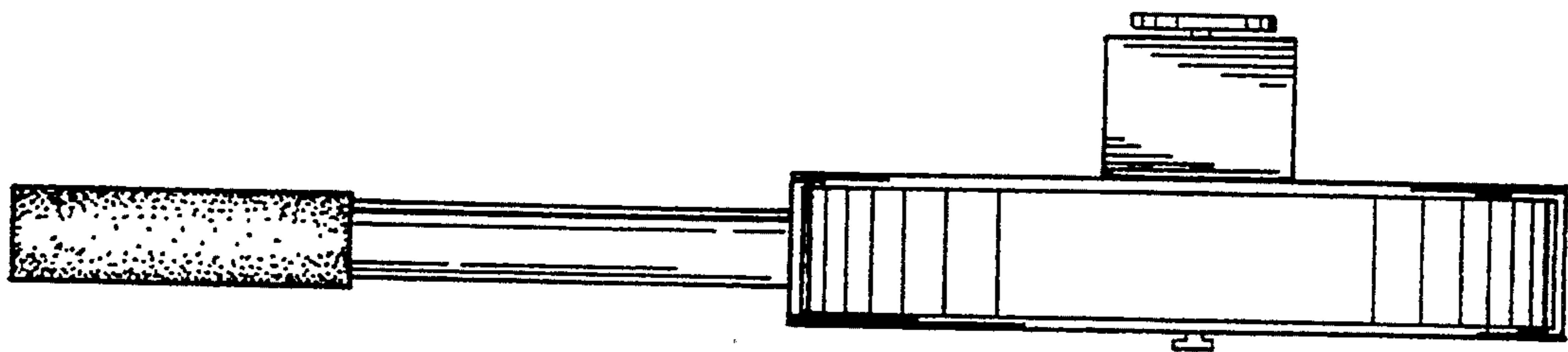

Fig. 3.

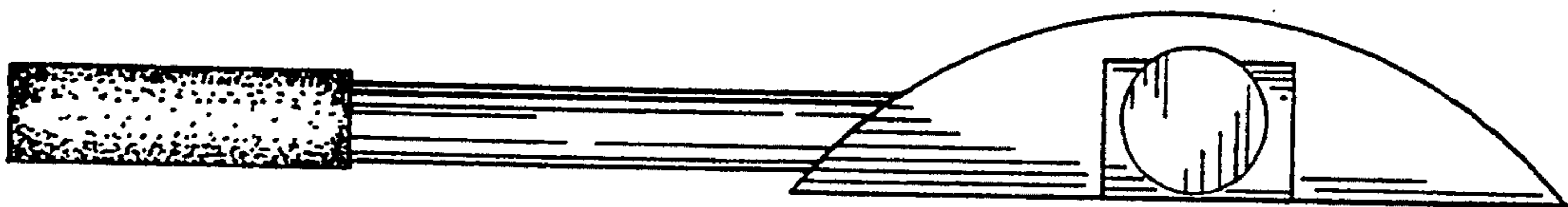

Fig. 4.

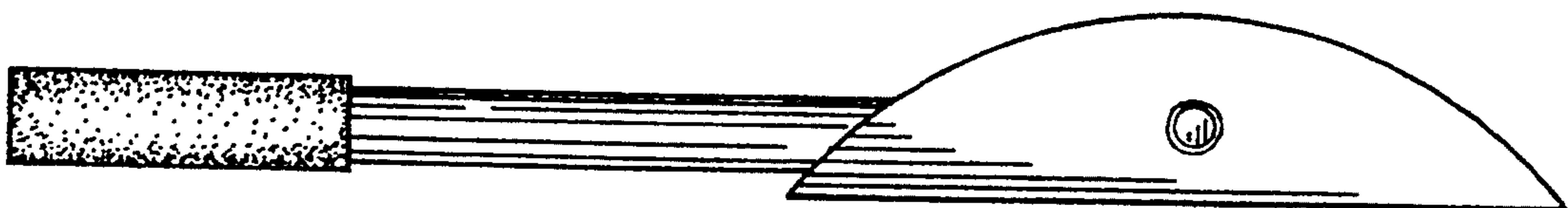

Fig. 5.



Fig. 6.

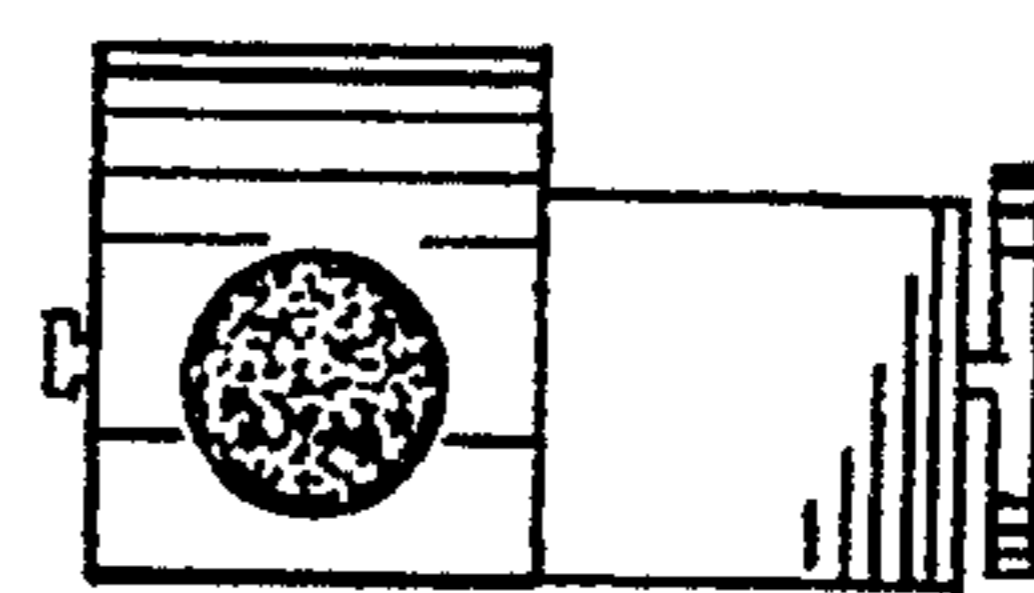

Fig. 7.