



US00D350127S

United States Patent [19]

[11] Patent Number: **Des. 350,127**

Gummeson et al.

[45] Date of Patent: **** Aug. 30, 1994**

[54] **STAND FOR A HANDHELD LASER SCANNER**

[75] Inventors: **Phillip C. Gummeson, Eugene; Jose Bravo, Tigard, both of Oreg.**

[73] Assignee: **Spectra-Physics Scanning Systems, Inc., Eugene, Oreg.**

[**] Term: **14 Years**

[21] Appl. No.: **2,832**

[22] Filed: **Dec. 21, 1992**

[52] U.S. Cl. **D14/116**

[58] Field of Search 248/122, 125, 127, 133, 248/149, 161, 178, 371, 183, 671, 676, 917-924; D6/396, 418, 429, 457; D14/114, 116; D21/48

[56] **References Cited**

U.S. PATENT DOCUMENTS

D. 275,431	9/1984	Usab	248/921 X
D. 281,657	12/1985	Rolzey	248/918 X
295,415	4/1988	Thies et al.	D14/114
D. 308,968	7/1990	Morun et al.	D14/114
D. 312,631	12/1990	Schorr et al.	D14/114
D. 320,980	10/1991	Howard et al.	D14/114
5,088,676	2/1992	Orchard et al.	248/922 X
5,181,681	1/1993	Edwards	248/125
5,240,341	8/1993	Peng	248/921 X
5,242,140	9/1993	Ritland	248/122

OTHER PUBLICATIONS

Brochure: Accessories Sheet for the PSC 5300 and 5400 Series Laser Scanners, PSC, Inc., Webser, N.Y. (12 pages).

Brochure: FlexStand Accessory Sheet for the SP300 Handheld Laser Scanner, Spectra-Physics Scanning System, Inc., Eugene, OR (1991) (2 pages).

Brochure: Accessories Sheet for the Symbolstand™ Series stands for Handheld Laser Scanners, Symbol Technologies, Inc., Bohemia, N.Y. (1991) (2 pages) and copies of photographs (2) of same.

Primary Examiner—Wallace R. Burke

Assistant Examiner—M. H. Tung

Attorney, Agent, or Firm—Lyon & Lyon

[57] **CLAIM**

The ornamental design for a stand for a handheld laser scanner, as shown and described.

DESCRIPTION

FIG. 1 is a front, right side perspective view of a stand for a handheld laser scanner showing my new design; FIG. 2 is a top plan view thereof; FIG. 3 is a front side elevational view thereof; FIG. 4 is a right side elevational view thereof; FIG. 5 is a rear side elevational view thereof; FIG. 6 is a bottom plan view thereof; and, FIG. 7 is front, right side perspective view thereof with the stand in the extended position.

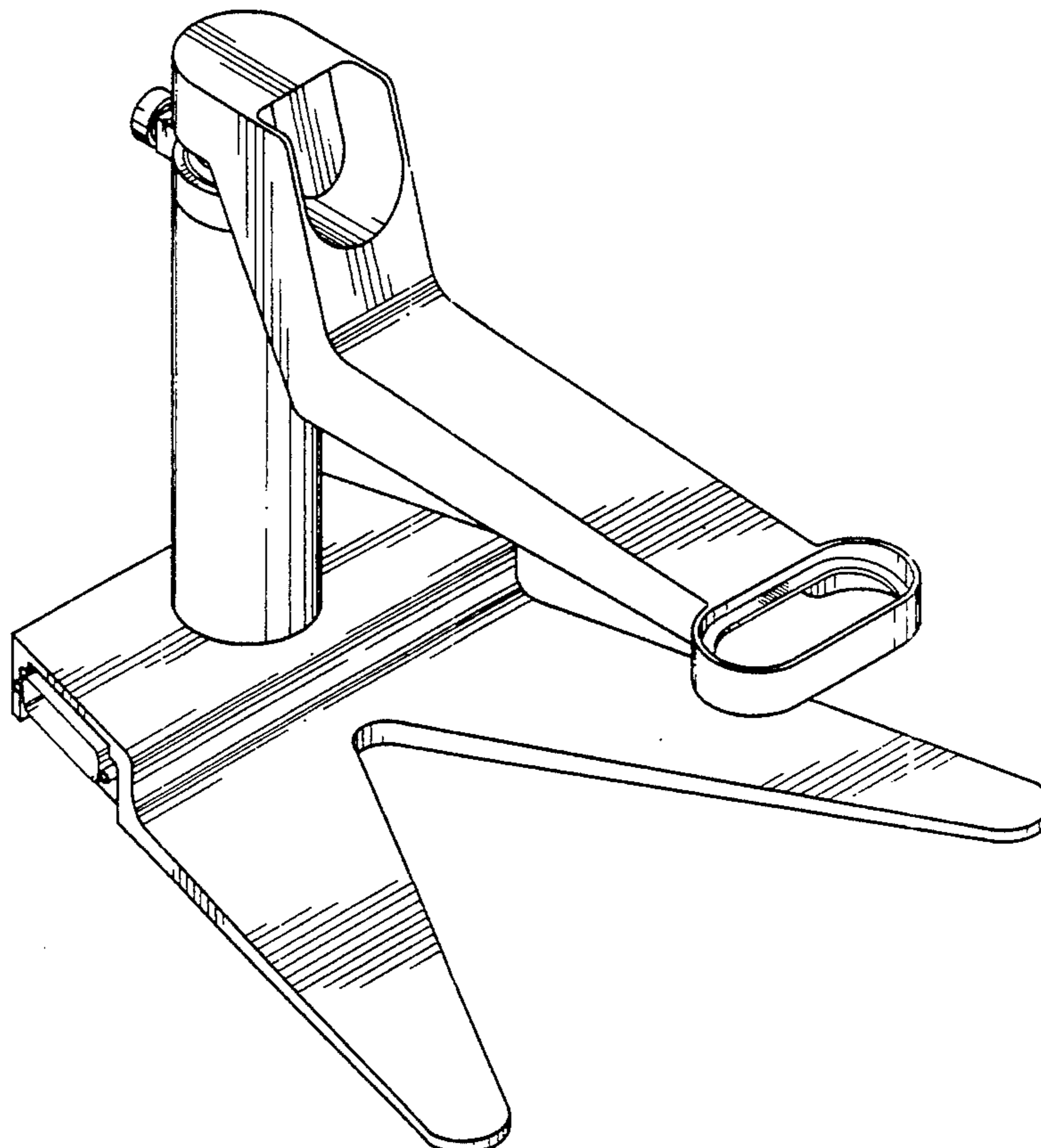

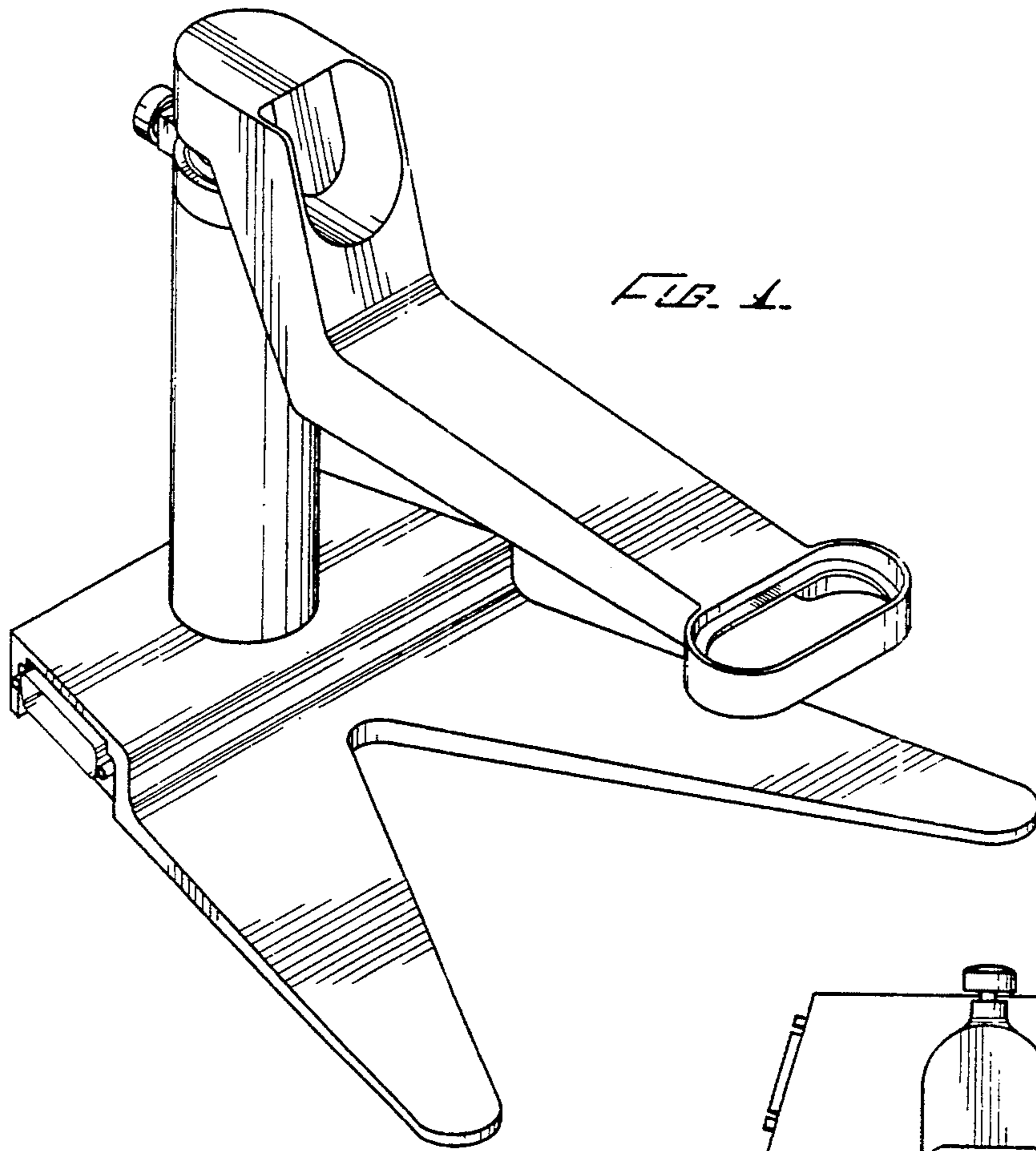

FIG. 1.

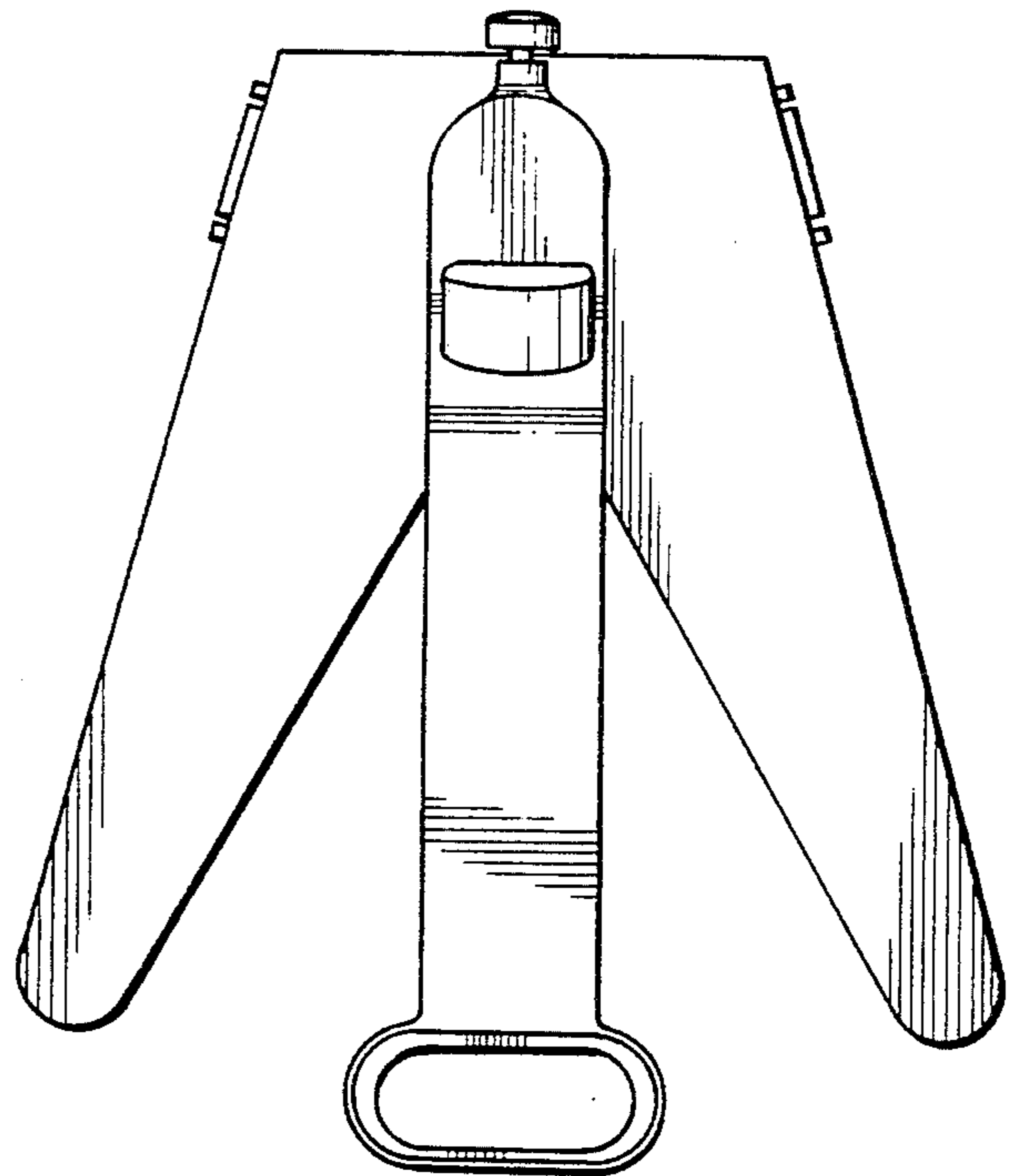

FIG. 2.

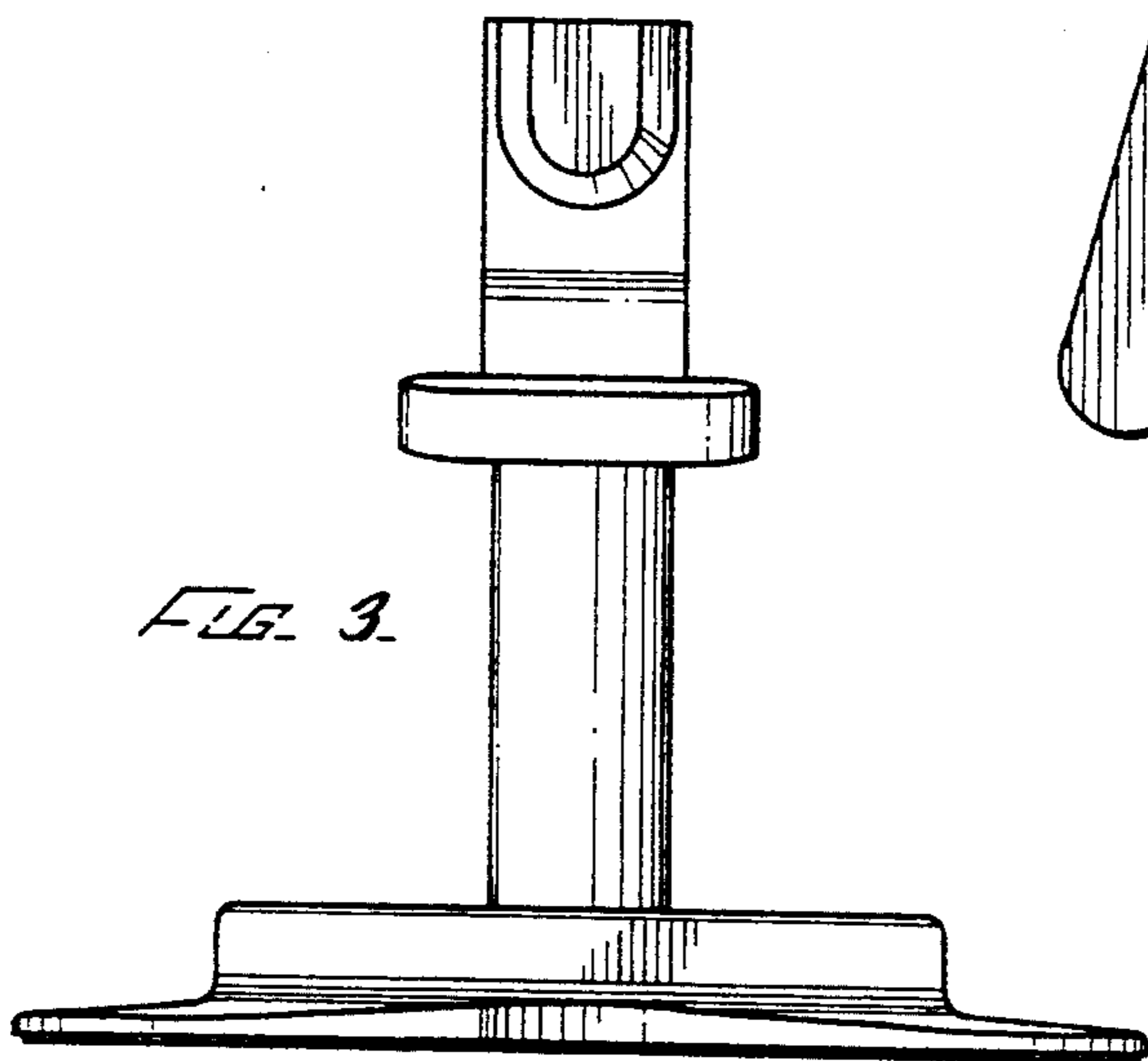

FIG. 3.

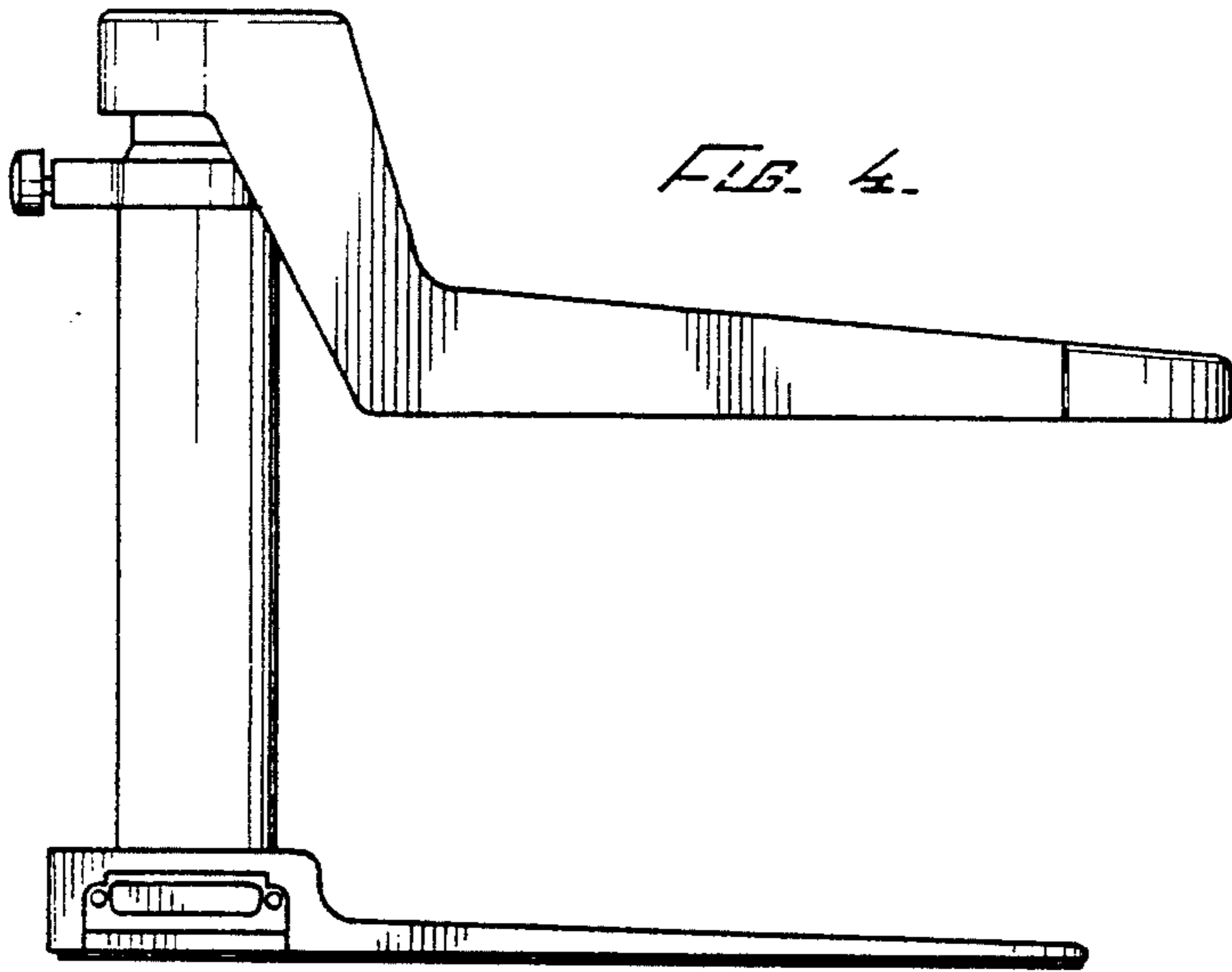

FIG. 4.

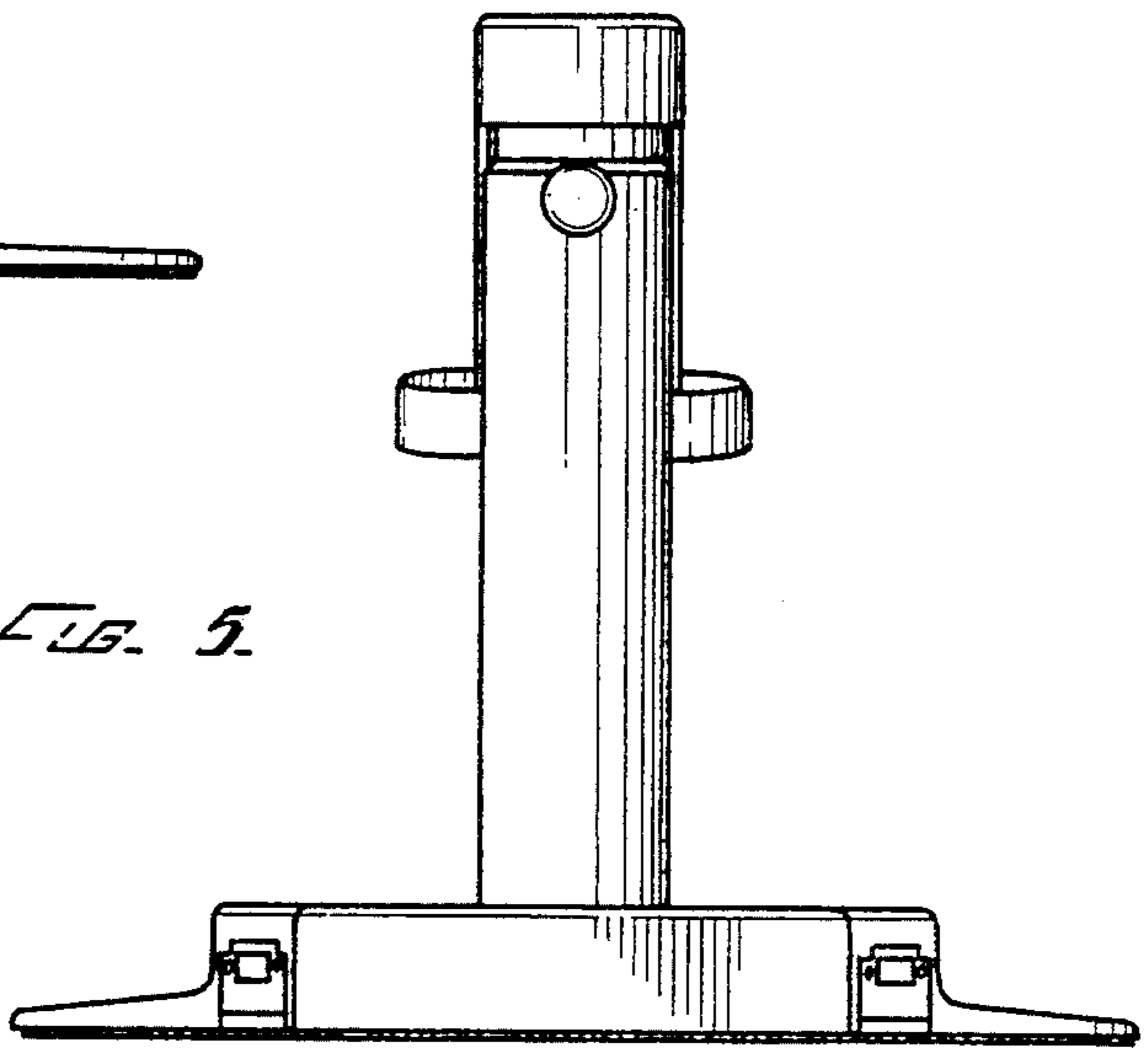

FIG. 5.

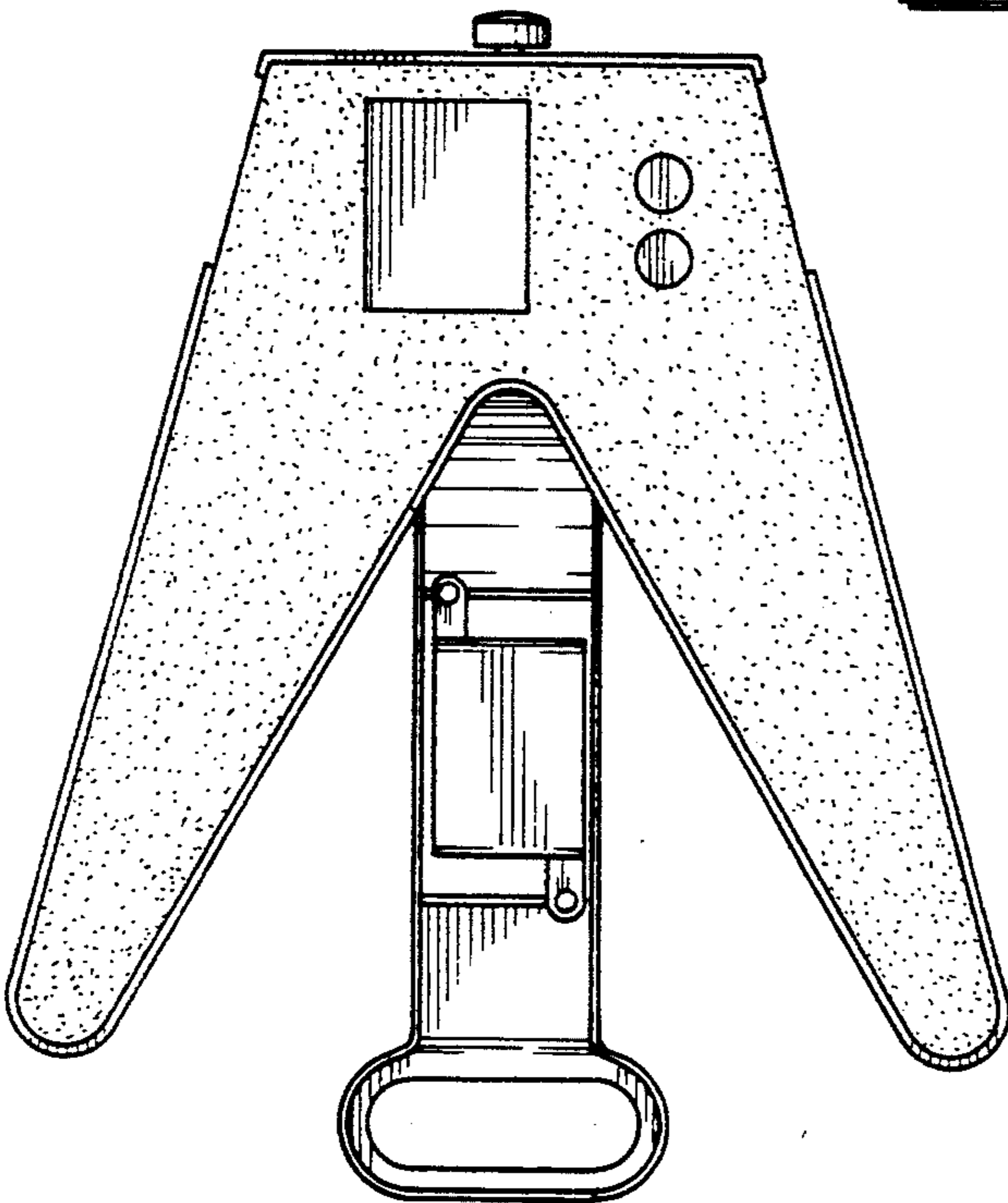

FIG. 6.

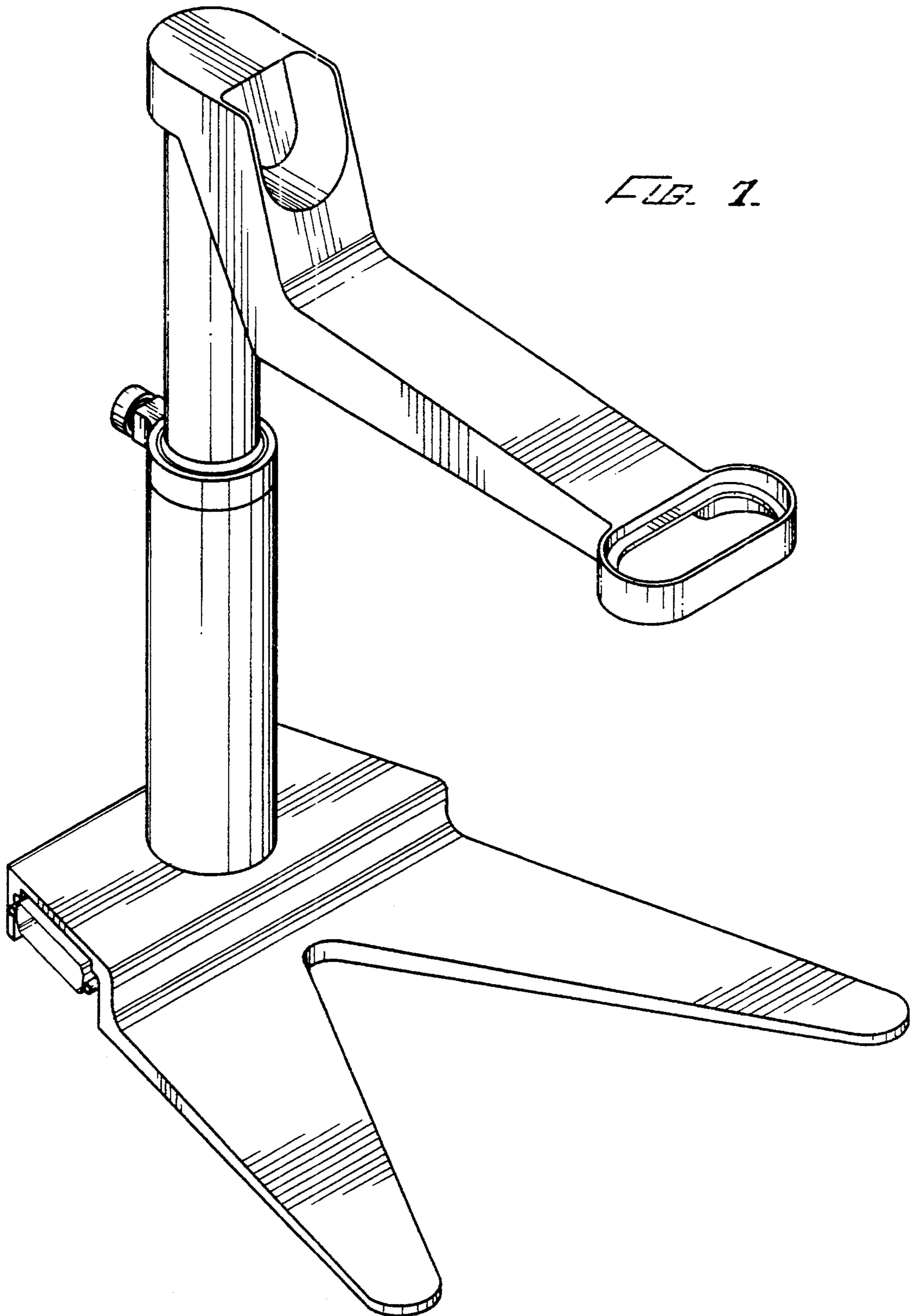

FIG. 1.