



US00D350086S

United States Patent [19]

[11] Patent Number: Des. 350,086

Kong et al.

[45] Date of Patent: ** Aug. 30, 1994

[54] AUTOMOBILE BODY

[75] Inventors: **Richard C. Kong**, LaCosta, Calif.; **Dennis Myles**, W. Bloomfield, Mich.; **Erich O. Kugler**, Royal Oak, Mich.; **Robert J. Janosko**, Bloomfield Hills, Mich.; **Timothy W. Anness**, San Diego, Calif.; **Daniel J. Sims**, Lake Forrest, Calif.

[73] Assignee: **Chrysler Corporation**, Highland Park, Mich.

[*] Notice: The portion of the term of this patent subsequent to May 24, 2008 has been disclaimed.

[**] Term: **14 Years**

[21] Appl. No.: **870,709**

[22] Filed: **Apr. 17, 1992**

[52] U.S. Cl. **D12/92**

[58] Field of Search 296/185; D12/91, 92

[56] References Cited

U.S. PATENT DOCUMENTS

- D. 301,436 6/1989 Mizuno et al. D12/92
- D. 334,357 3/1993 Hirata et al. D12/92

OTHER PUBLICATIONS

- Road & Track, Oct. 1991, p. 38, Toyota Corolla ET-A-PEX Automobile, top of page.
- Road & Track, Dec. 1991, p. 37, 1995 Ford Taurus, bottom of page.
- Motor Trend, Mar. 1990, p. 14, Ford Thunderbird, bottom of page.
- 1992 Chrysler Plymouth Brochure, printed Sep. 1991, pp. 8 & 9, Chrysler LeBaron Convertible & Coupe, top of page.

Primary Examiner—James M. Gandy
Attorney, Agent, or Firm—Mark P. Calcaterra

[57] CLAIM

The ornamental design for an automobile body, as shown and described.

DESCRIPTION

FIG. 1 is a front perspective view of an automobile body illustrating our new design, it being understood that the broken line showing of the tires and wheels and interior portions of the automobile body are for illustrative purposes only and form no part of the claimed design;

FIG. 2 is a rear perspective view of the automobile body shown in FIG. 1;

FIG. 3 is a side view of the automobile body shown in FIG. 1;

FIG. 4 is a front view of the automobile body shown in FIG. 1; and,

FIG. 5 is a rear view of the automobile body shown in FIG. 1.

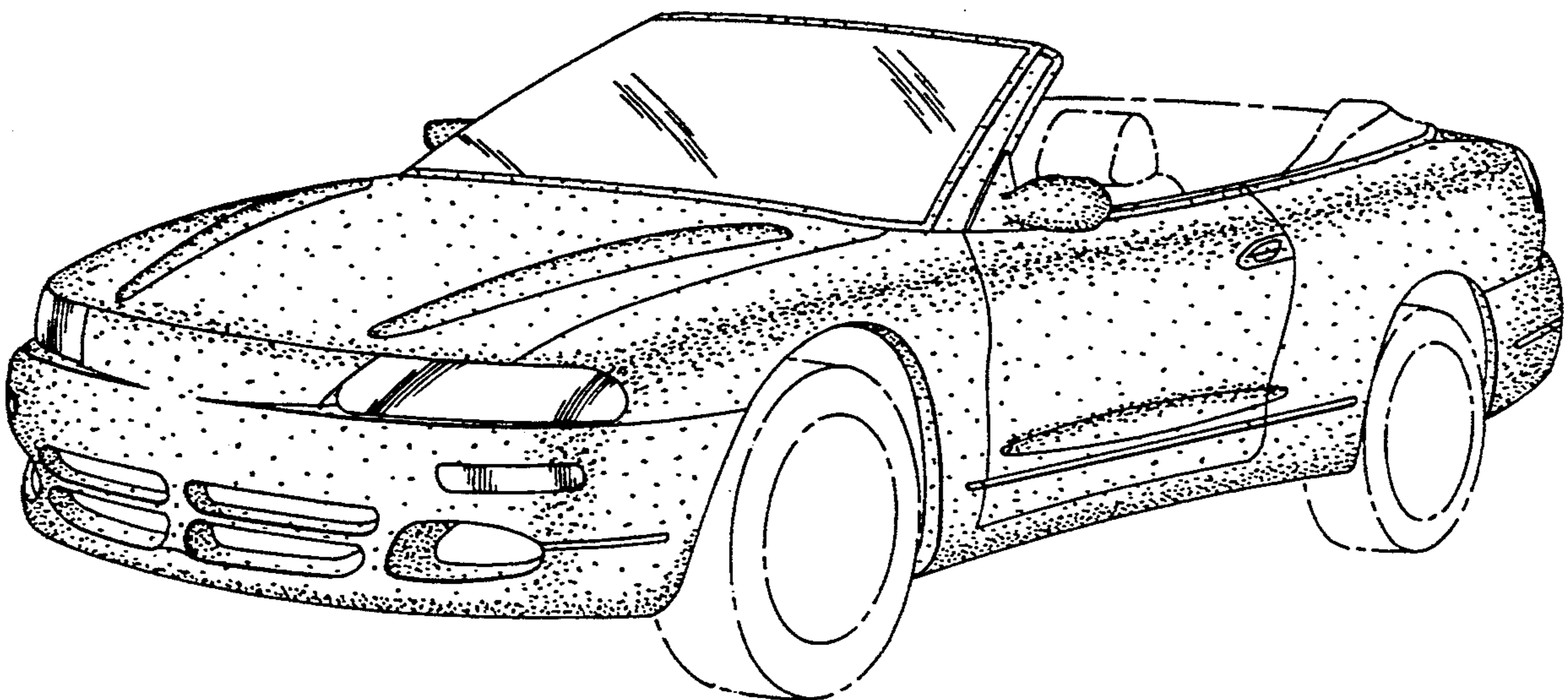

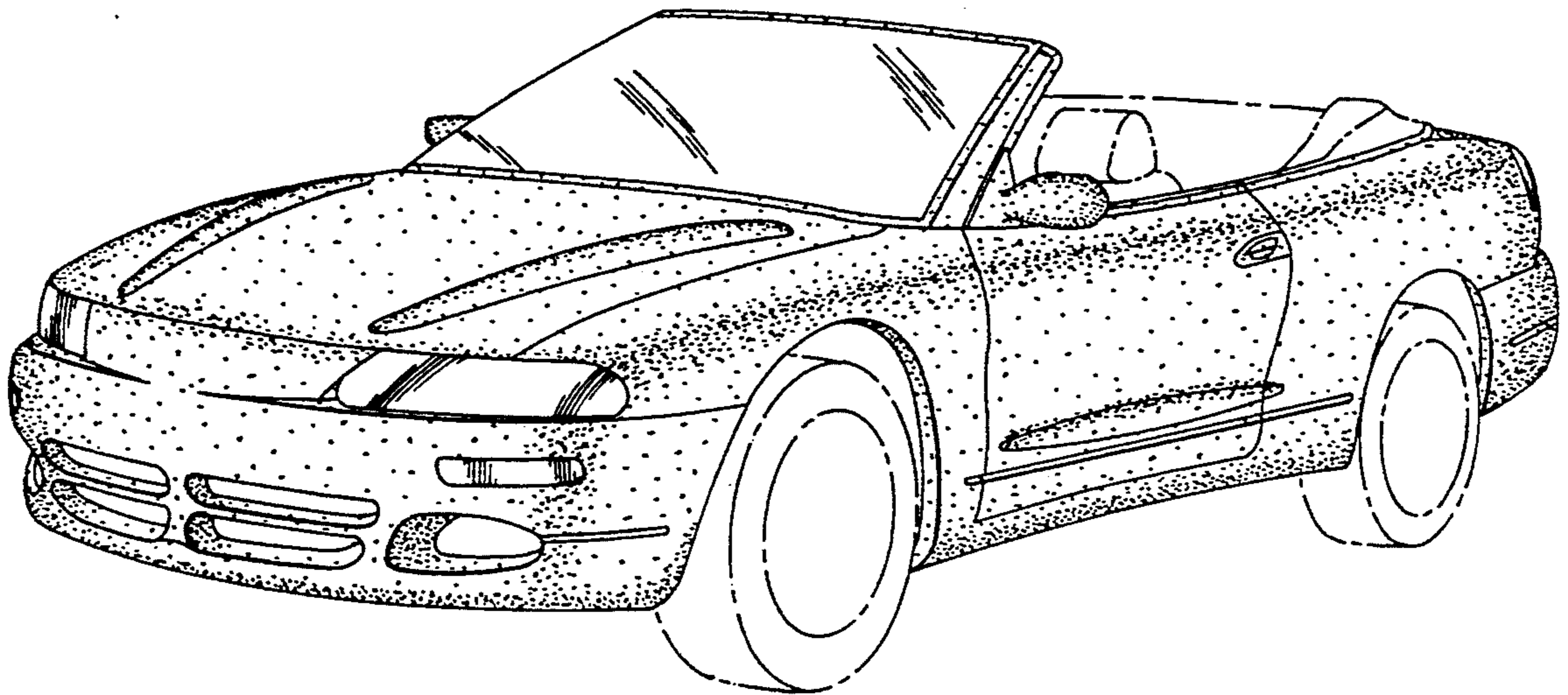

FIG. 1.

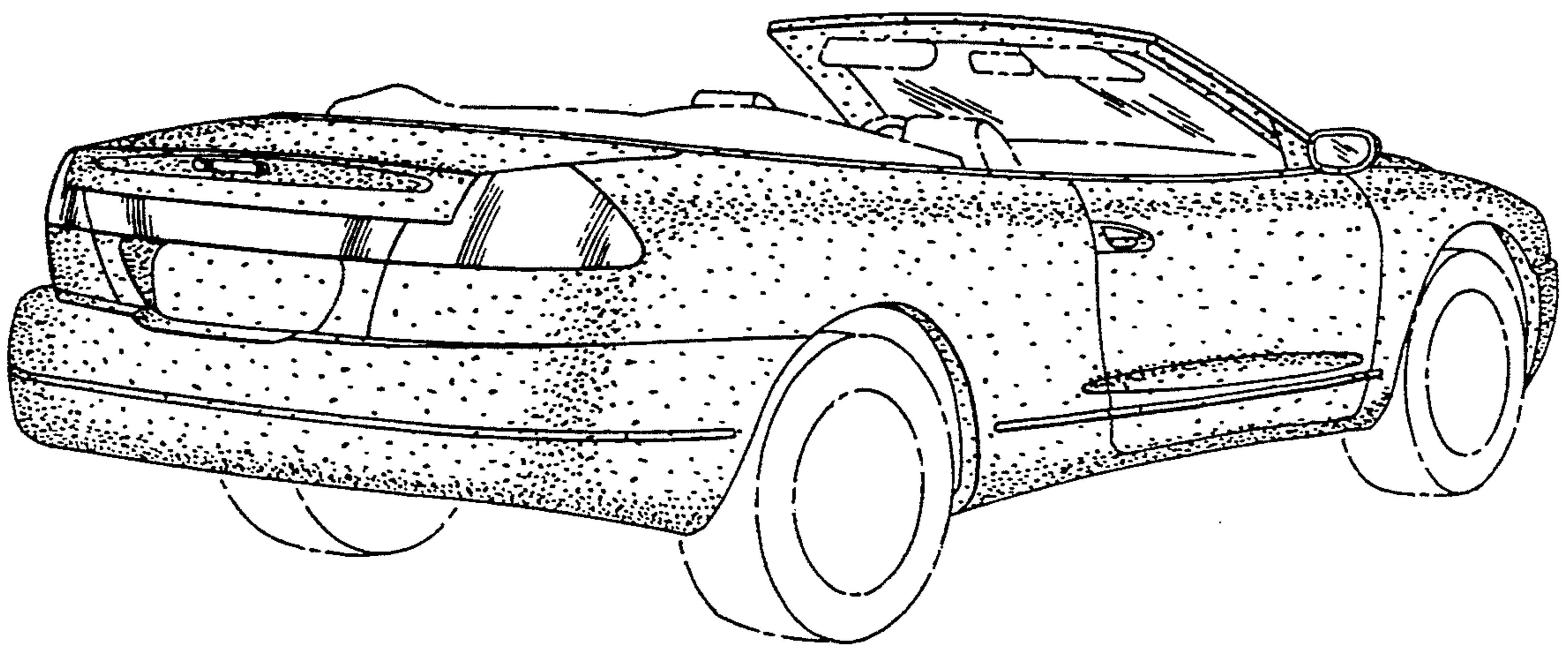

FIG. 2.

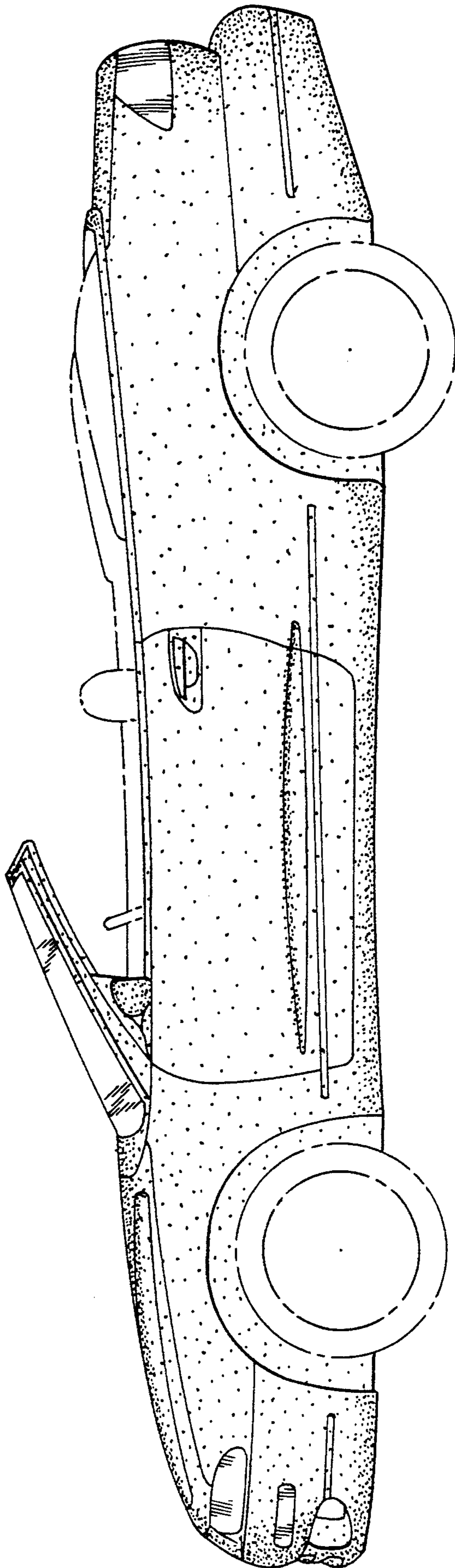

FIG. 2

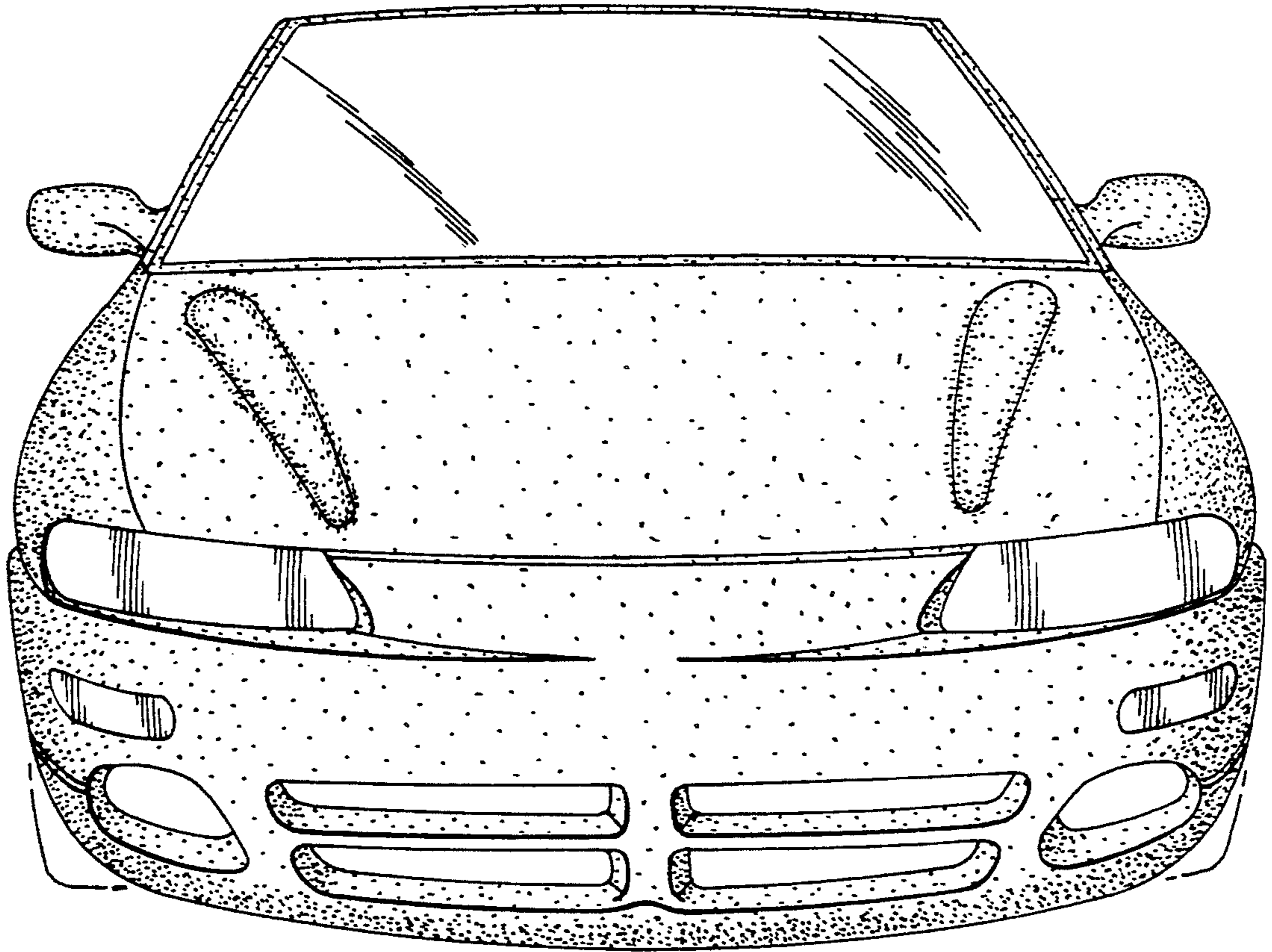
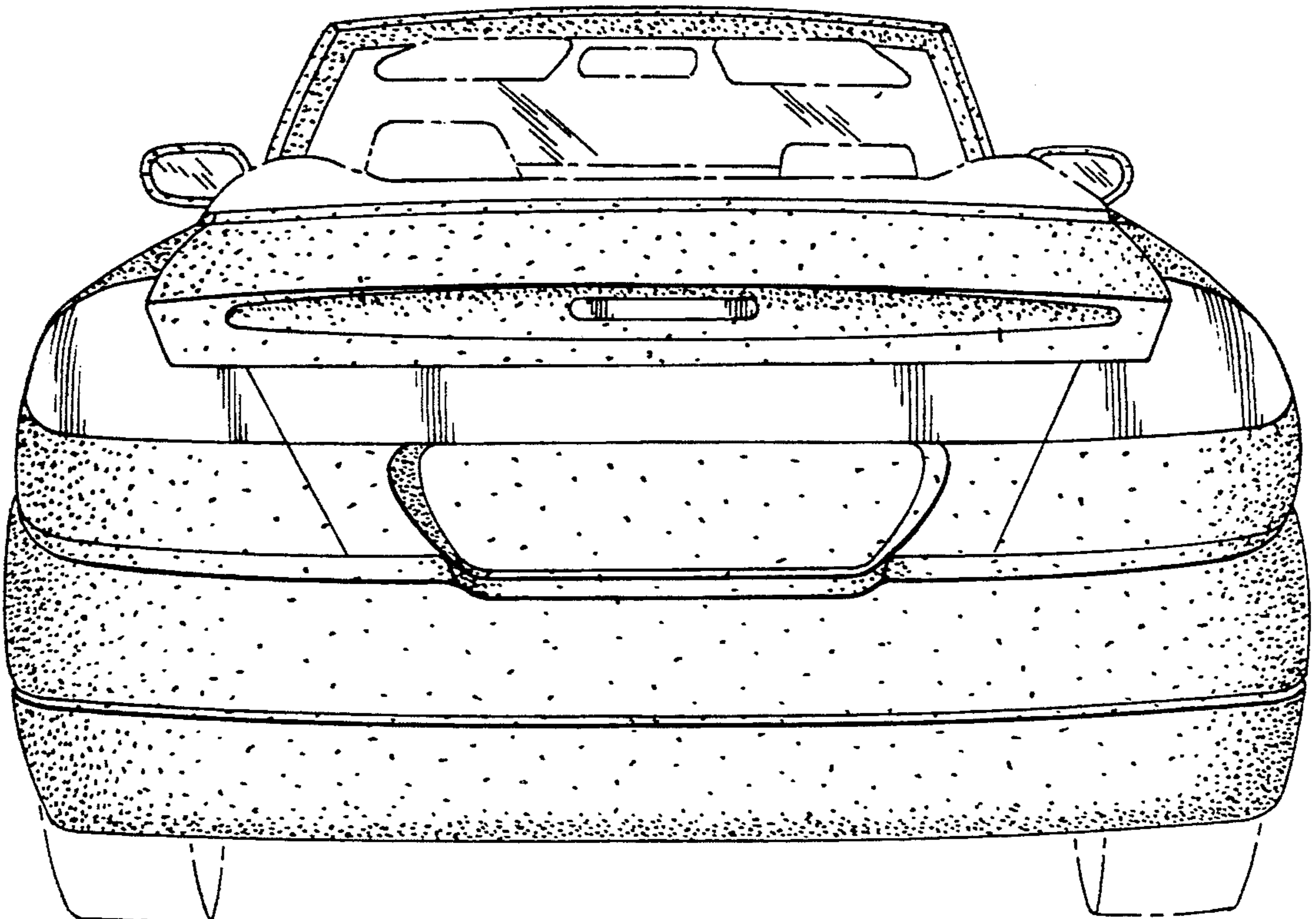

FIG. 4.

FIG. 5.



UNITED STATES PATENT AND TRADEMARK OFFICE
CERTIFICATE OF CORRECTION

PATENT NO. : D350,086
DATED : August 30, 1994
INVENTOR(S) : Kong, et al

It is certified that error appears in the above-identified patent and that said Letters Patent is hereby corrected as shown below:

ON THE TITLE PAGE, in Inventors block #75, "Dennis Myles, W. Bloomfield Maine" should be --Dennis Myles, W. Bloomfield, Michigan--.

Signed and Sealed this
Twenty-seventh Day of December, 1994

Attest:



BRUCE LEHMAN

Attesting Officer

Commissioner of Patents and Trademarks