



US00D349876S

# United States Patent [19]

[11] Patent Number: **Des. 349,876**

**Martin**

[45] Date of Patent: **\*\* Aug. 23, 1994**

[54] **TRUCK TAILGATE**

[76] Inventor: **Andrew J. Martin**, 981 Fassler Ave.,  
Pacifica, Calif. 94044

[\*\*] Term: **14 Years**

[21] Appl. No.: **7,003**

[22] Filed: **Apr. 13, 1993**

[52] U.S. Cl. .... **D12/196**

[58] Field of Search ..... 296/50, 55, 57.1, 60;  
D12/196, 98

[56] **References Cited**

**U.S. PATENT DOCUMENTS**

D. 231,521 4/1974 Rohrer ..... D12/196

D. 271,010 10/1983 Stephenson ..... D12/98

D. 295,278 4/1988 Smith ..... D12/196

**OTHER PUBLICATIONS**

Modern Plastics, Jun. 1974, p. 56, Rear End for '75  
Corvette, bottom left side of page.

*Primary Examiner*—James M. Gandy  
*Attorney, Agent, or Firm*—Burns, Doane, Swecker &  
Mathis

[57] **CLAIM**

The ornamental design for a truck tailgate, as shown  
and described.

**DESCRIPTION**

FIG. 1 is a front perspective view of a truck tailgate  
showing my new design in position of use on a pickup  
truck which is shown in broken lines for illustrative  
purposes only and forms no part of the claimed design;  
FIG. 2 is an enlarged front perspective view thereof;  
FIG. 3 is an enlarged front elevation view thereof;  
FIG. 4 is a top plan view of FIG. 3;  
FIG. 5 is a rear perspective view of FIG. 2;  
FIG. 6 is a side elevation view of FIG. 3 it being under-  
stood that the opposite side is a mirror image thereof;  
FIG. 7 is a top plan view of a truck tailgate showing a  
second embodiment of my new design;  
FIG. 8 is a slightly enlarged rear perspective view of  
the second embodiment it being understood that the  
front view thereof is the same as the first embodiment  
shown in FIGS. 1, 2 and 3; and,  
FIG. 9 is a side elevation view of the second embodi-  
ment it being understood that the opposite side is a  
mirror image thereof.  
The bottom surface of the two embodiments of the  
truck tailgate is understood to be flat and unorna-  
mented.

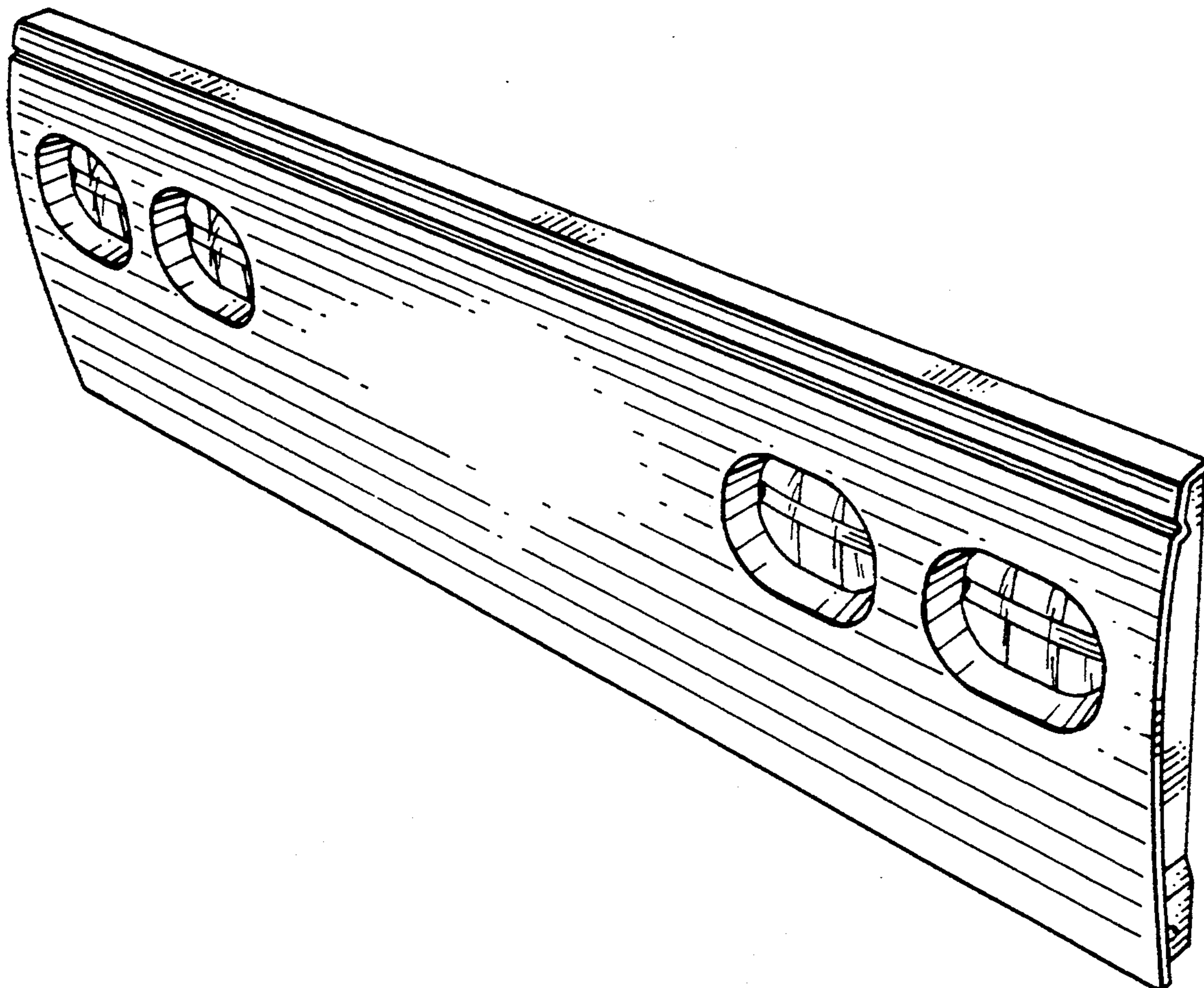

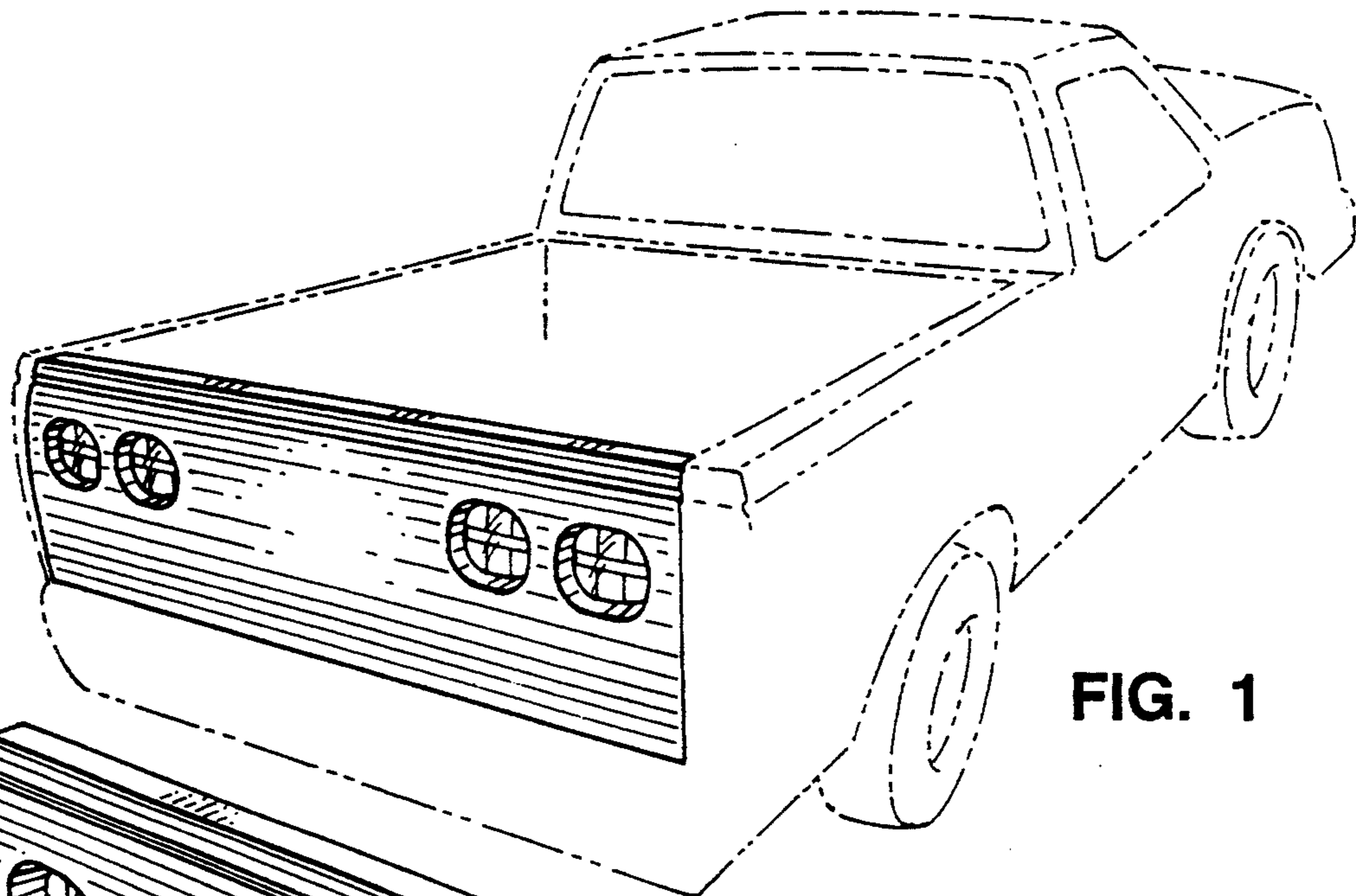

FIG. 1

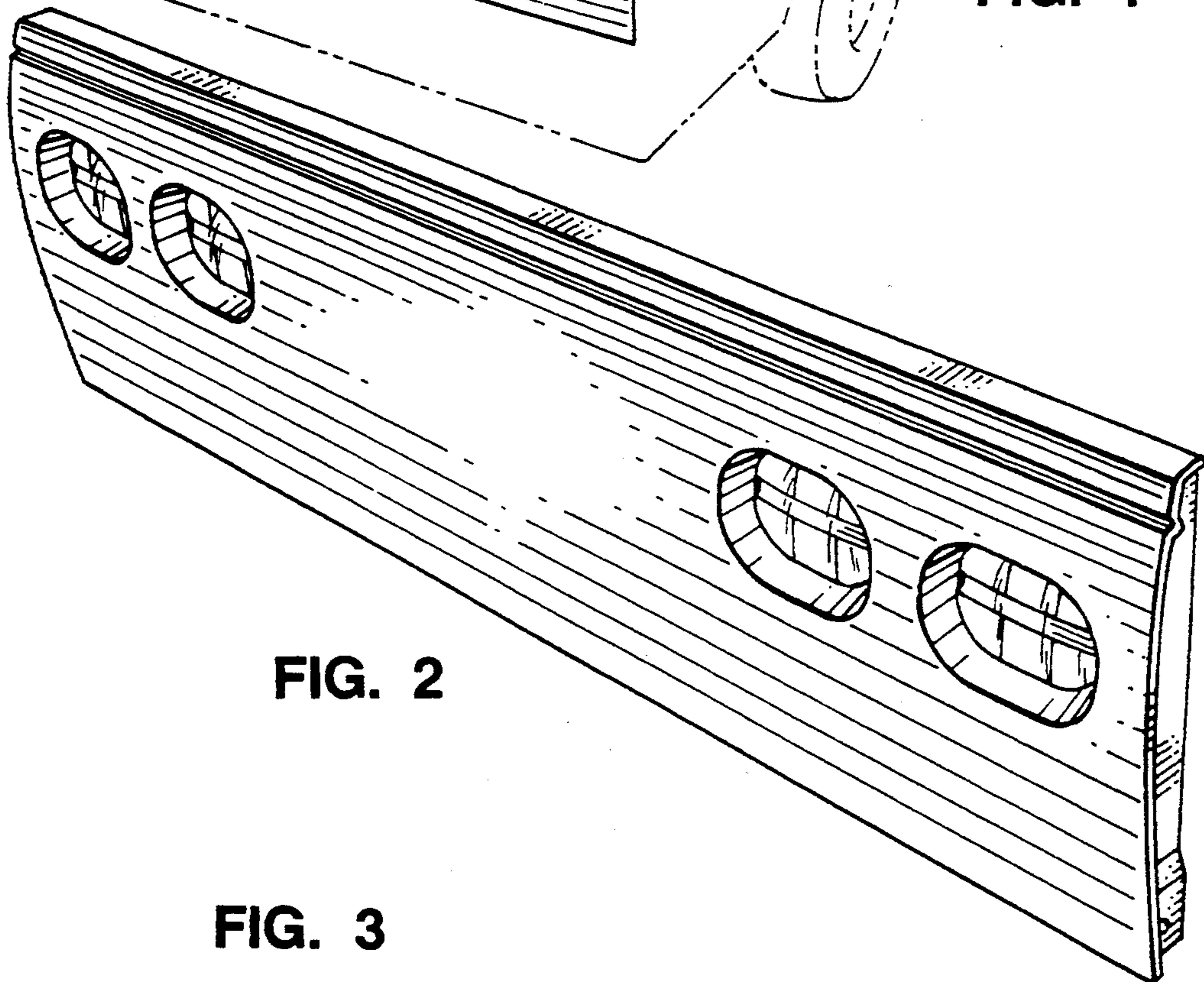

FIG. 2

FIG. 3

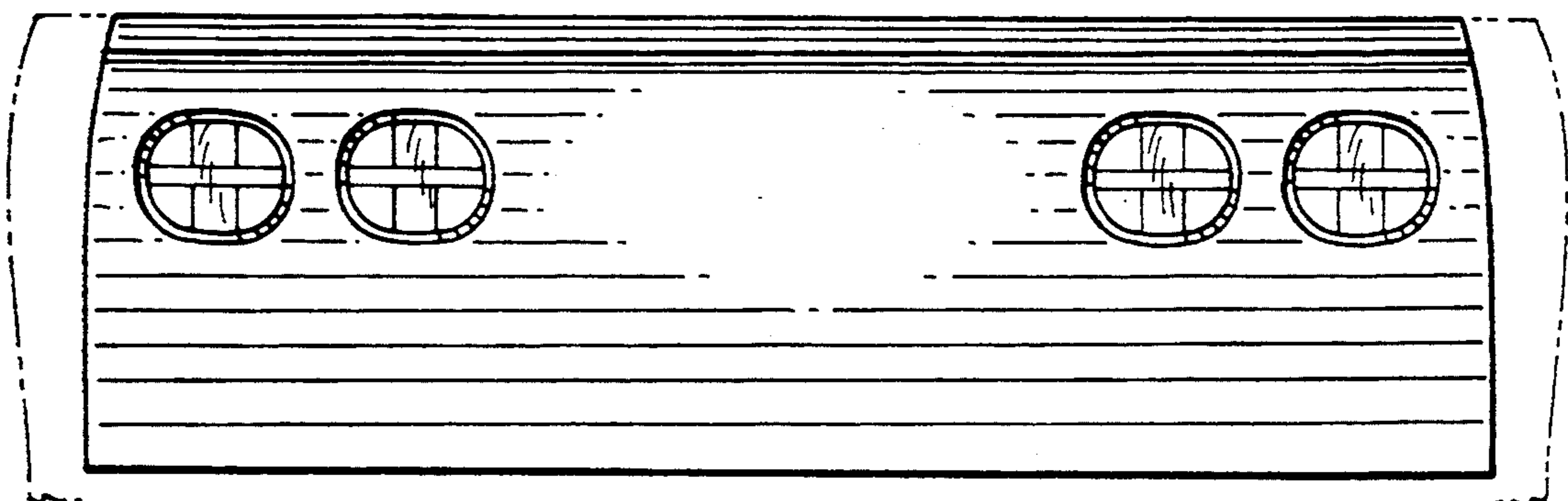





FIG. 4

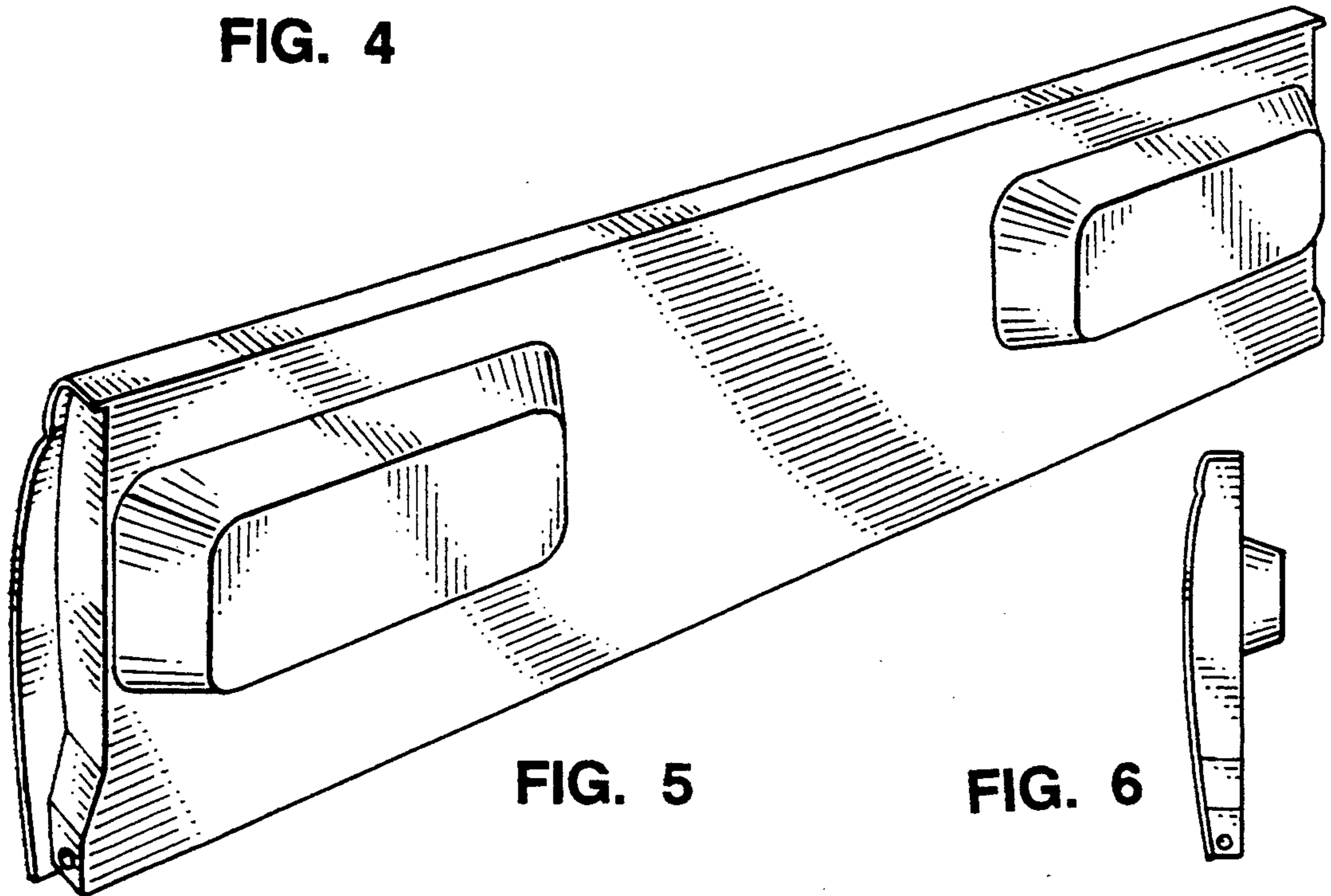

FIG. 5

FIG. 6

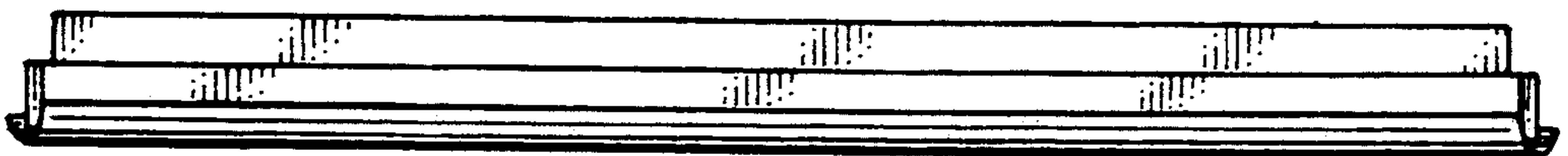

FIG. 7

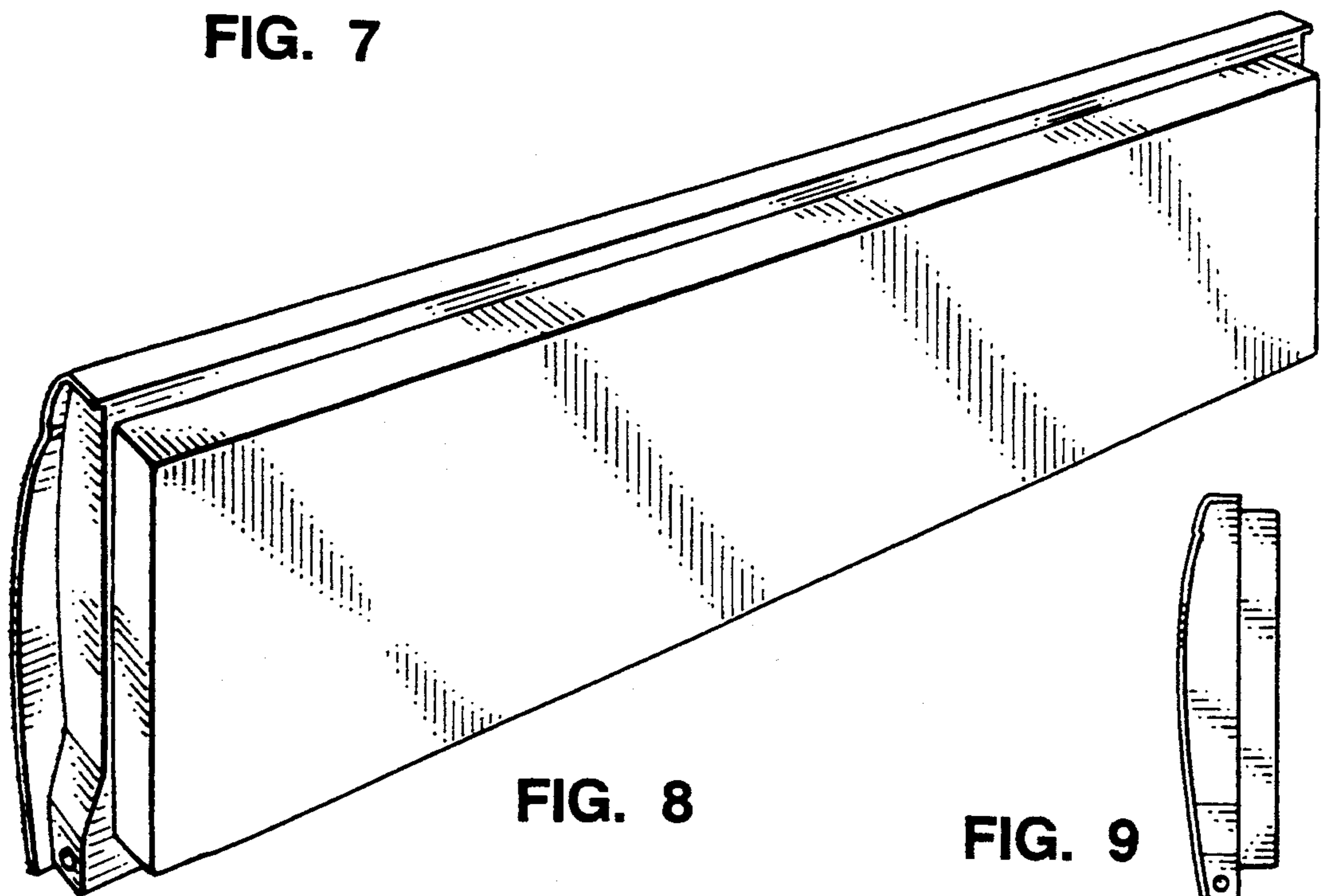

FIG. 8

FIG. 9

