



US00D349839S

United States Patent [19]

[11] Patent Number: **Des. 349,839**

Gilardelli

[45] Date of Patent: **** Aug. 23, 1994**

[54] **ANTI-THEFT STEERING WHEEL LOCK**

[75] Inventor: **Federico Gilardelli, Milan, Italy**
 [73] Assignee: **The Rock Italia Di Alfredo Baldieri, Milan, Italy**
 [**] Term: **14 Years**
 [21] Appl. No.: **12,666**
 [22] Filed: **Sep. 7, 1993**
 [52] U.S. Cl. **D8/331**
 [58] Field of Search **D8/330-331, D8/333, 339, 341; 70/14, 233, 237-238, 245, 247, 252**

[56] **References Cited**

U.S. PATENT DOCUMENTS

D. 323,969	2/1992	Wang	D8/331
D. 328,233	7/1992	Rong	D8/331
D. 330,840	11/1992	Chen	D8/331
D. 342,886	1/1994	Su	D8/331
5,257,518	11/1993	Hsieh	70/238

Primary Examiner—Brian N. Vinson
Attorney, Agent, or Firm—Stephen Donovan

[57] **CLAIM**

The ornamental design for a anti-theft steering wheel lock, as shown and described.

DESCRIPTION

FIG. 1 is a top, front, and left side perspective view of an anti-theft steering wheel lock showing our new design;
 FIG. 2 is an enlarged top plan view thereof;
 FIG. 3 is an enlarged bottom plan view thereof;
 FIG. 4 is an enlarged right side elevational view thereof;
 FIG. 5 is an enlarged left side elevational view thereof;
 FIG. 6 is an enlarged front elevational view thereof;
 FIG. 7 is an enlarged rear elevational view thereof;
 FIG. 8 is an enlarged right side elevational view thereof;
 FIG. 9 is an enlarged top plan view thereof, shown in an engaged position;
 FIG. 10 is a right side elevational view of a second embodiment thereof, the only difference residing in the use of different color, as indicated;
 FIG. 11 is a right side elevational view of a third embodiment thereof, the only difference residing in the use of different color, as indicated;
 FIG. 12 is a right side elevational view of a fourth embodiment thereof, the only difference residing in the use of different color, as indicated; and,
 FIG. 13 is a right side elevational view of a fifth embodiment thereof, the only difference residing in the use of different color, as indicated.

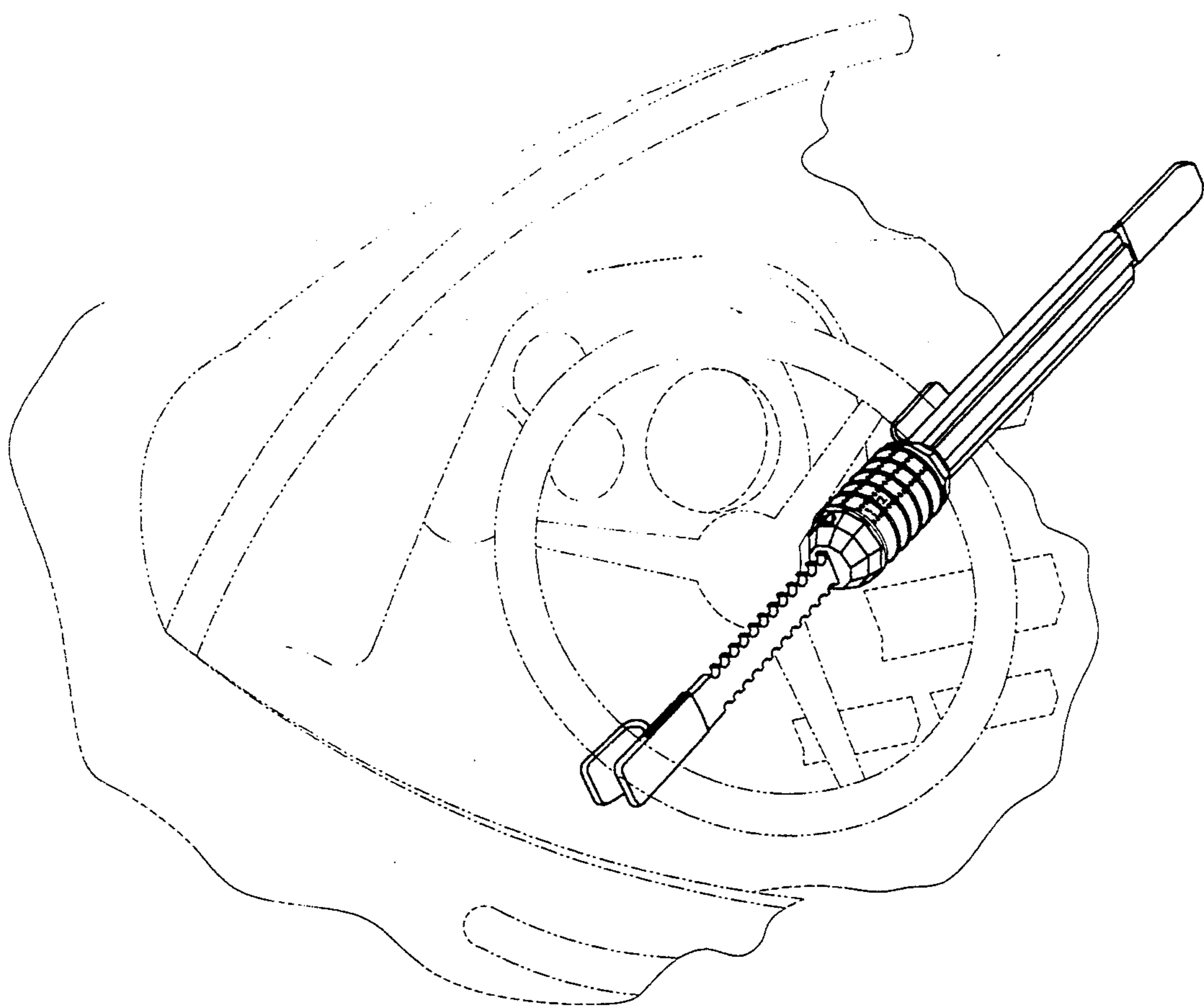

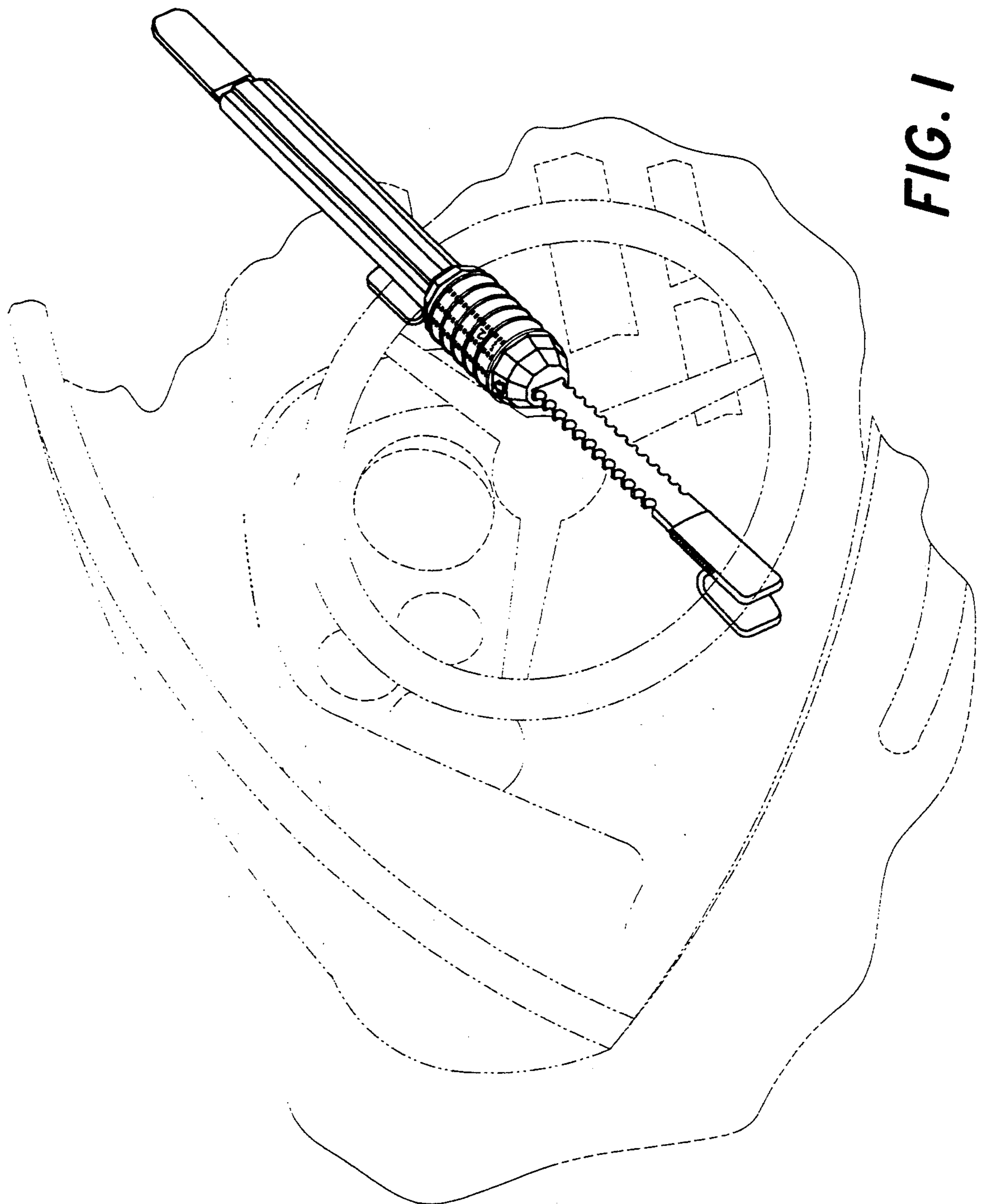

FIG. 1

FIG. 2

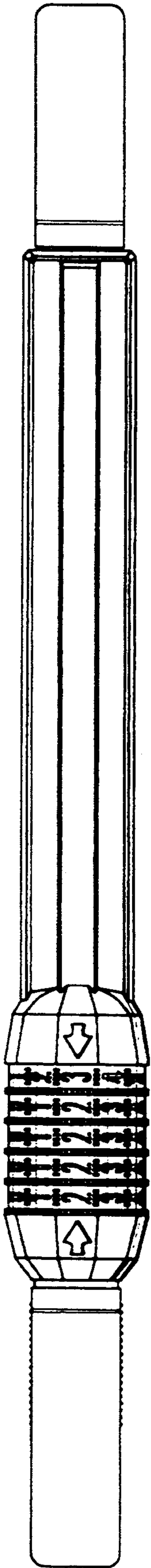

FIG. 3

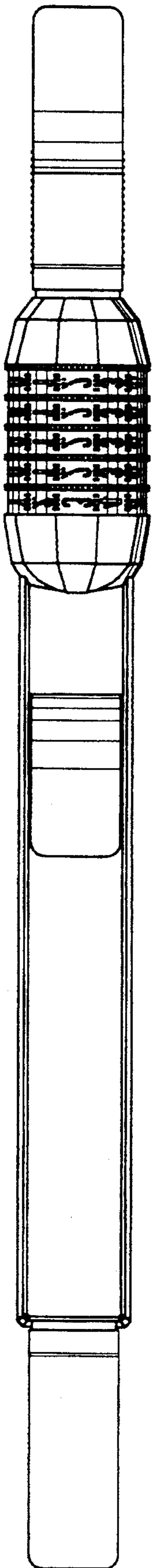

FIG. 4

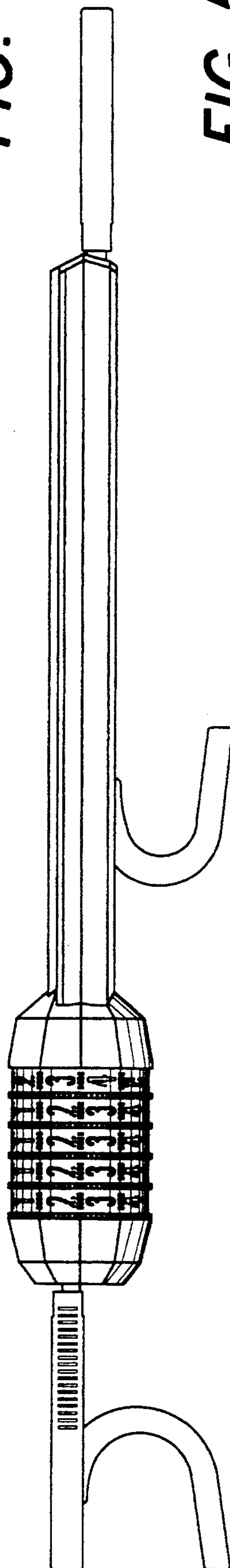

FIG. 5

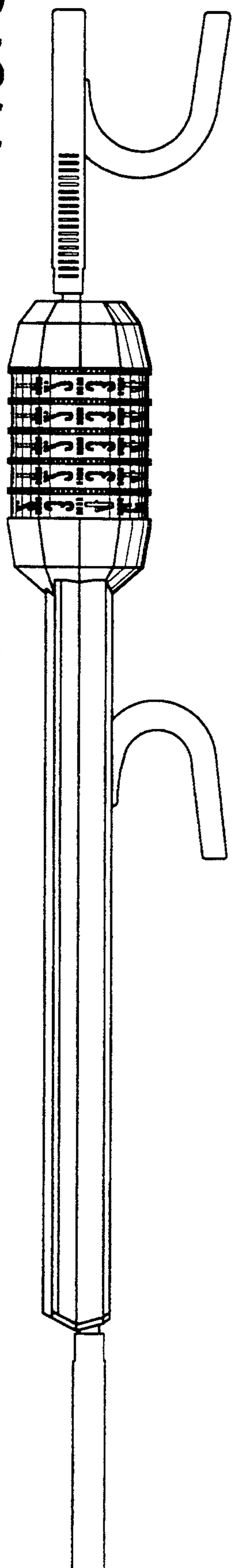

FIG. 6

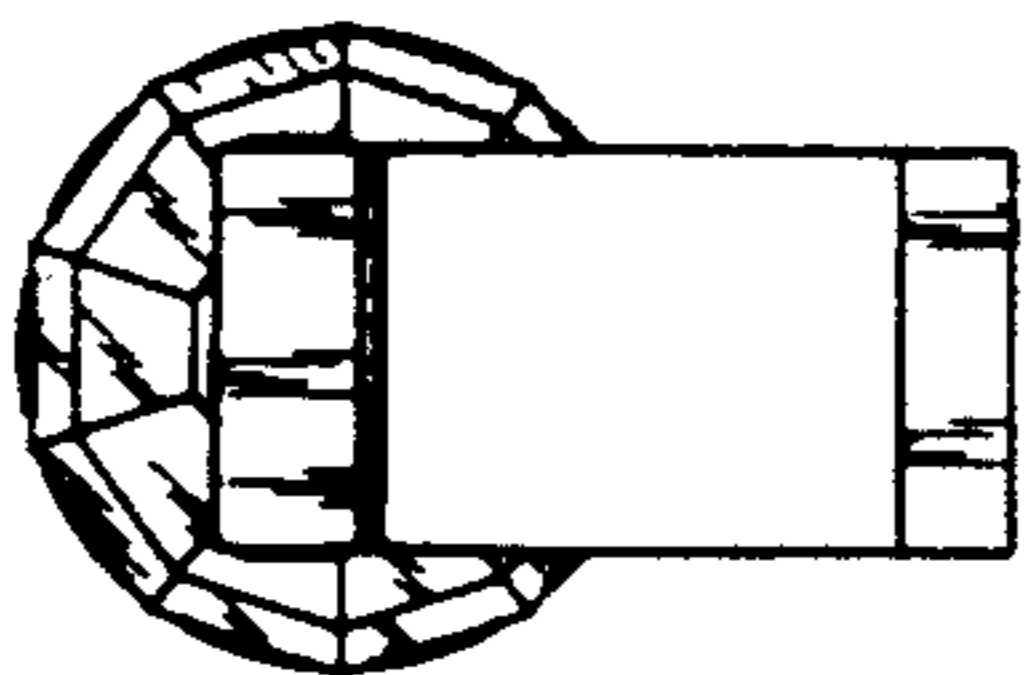

FIG. 8

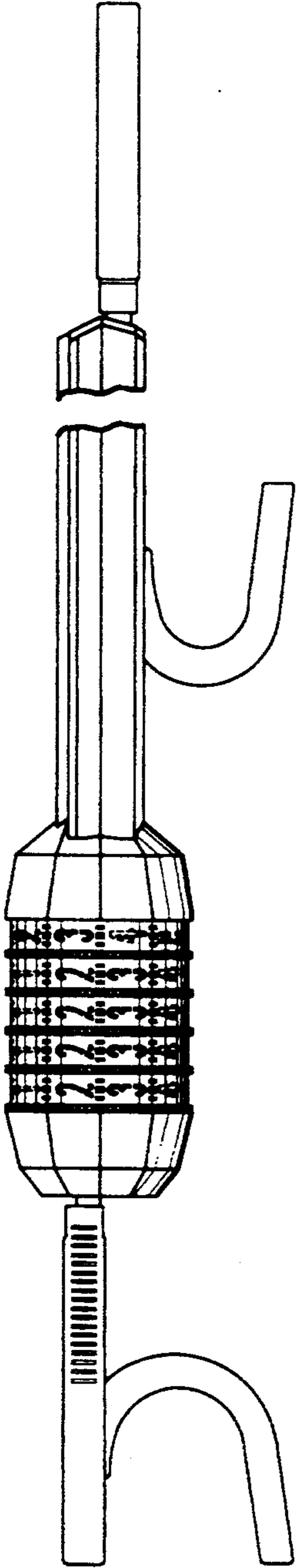

FIG. 7

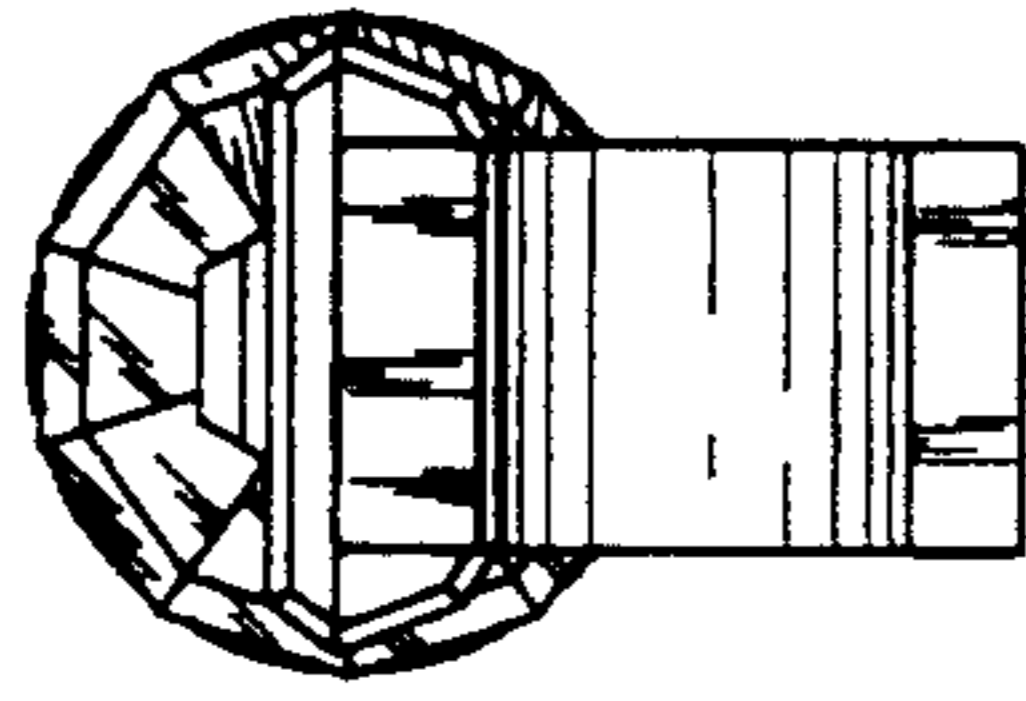

FIG. 9

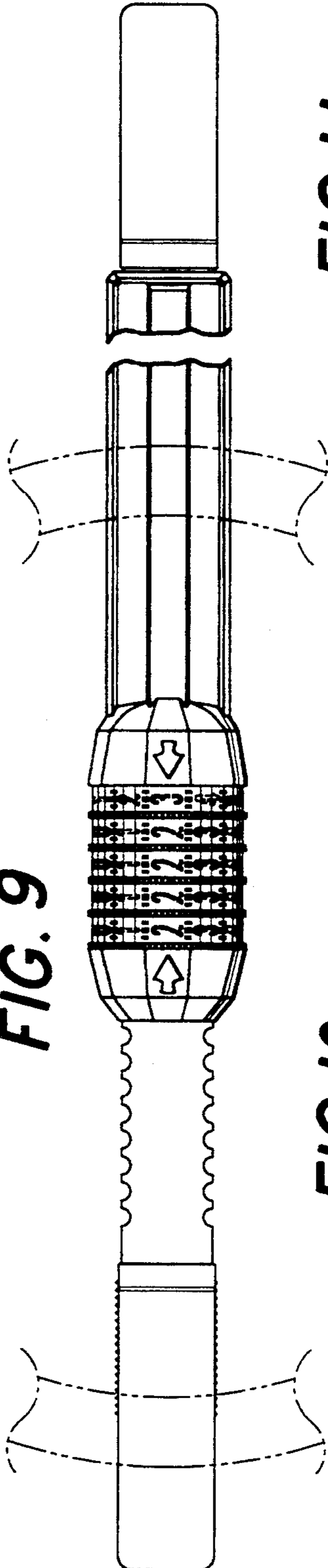

FIG. 10

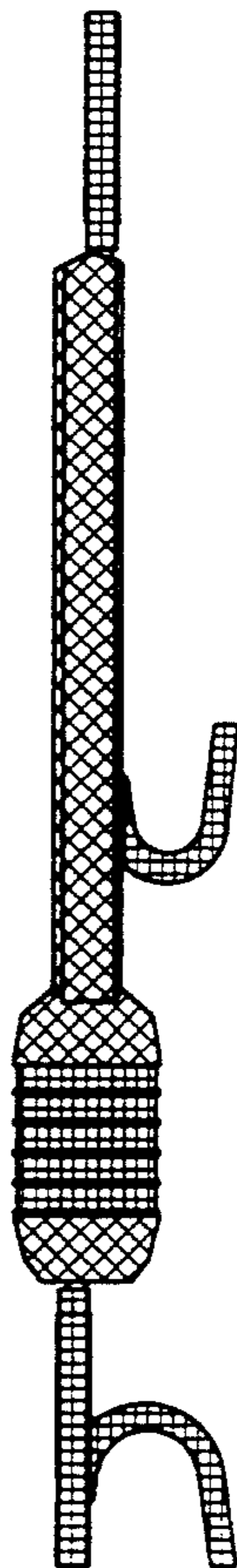

FIG. 11

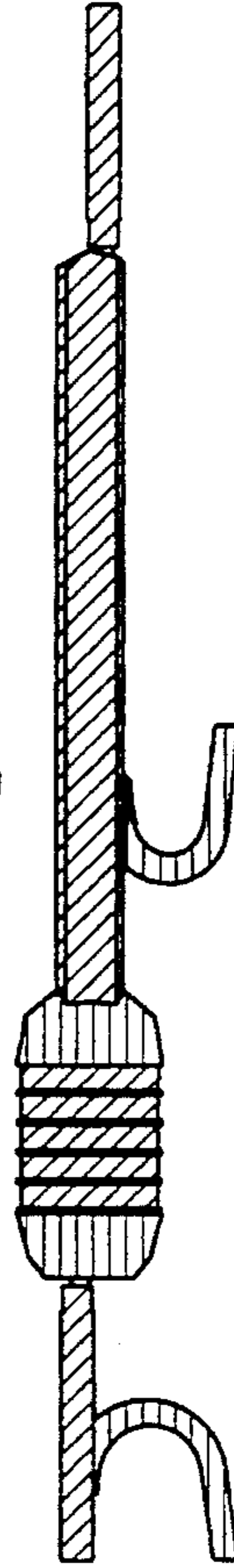

FIG. 12

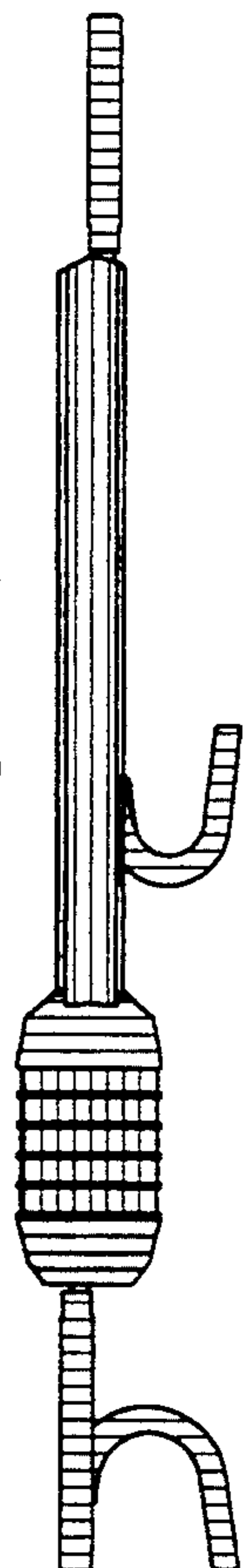

FIG. 13

