



US00D349271S

United States Patent [19]

[11] Patent Number: **Des. 349,271**

Inoue et al.

[45] Date of Patent: **** Aug. 2, 1994**

[54] AIRPLANE

[75] Inventors: **Kazuo Inoue**, Nerima; **Michimasa Fujino**, Komae, both of Japan

[73] Assignee: **Honda Giken Kogyo Kabushiki Kaisha**, Tokyo, Japan

[**] Term: **14 Years**

[21] Appl. No.: **846,417**

[22] Filed: **Mar. 6, 1992**

[52] U.S. Cl. **D12/337; D12/342**

[58] Field of Search **244/45 R, 45 A, 55, 244/46, 15; D12/319, 333, 334, 336, 337, 339, 340, 341, 342, 343, 344**

[56] References Cited

U.S. PATENT DOCUMENTS

D. 280,892 10/1985 Mazzoni D12/337

OTHER PUBLICATIONS

Jane's All the World's Aircraft 1973-74, p. 94 German Aircraft "MBB HFB Hansa Twin-Jet Executive Transport".

Primary Examiner—**Kay H. Chin**

Attorney, Agent, or Firm—**Lyon & Lyon**

[57] CLAIM

The ornamental design for an airplane, as shown and described.

DESCRIPTION

FIG. 1 is a top plan view of an airplane showing our new design;

FIG. 2 is a front elevational view thereof;

FIG. 3 is a left side elevational view thereof;

FIG. 4 is a right side elevational view thereof;

FIG. 5 is a rear elevational view thereof;

FIG. 6 is a bottom plan view thereof;

FIG. 7 is a top plan view of a second embodiment of the airplane;

FIG. 8 is a front elevational view of FIG. 7;

FIG. 9 is a rear elevational view of FIG. 7;

FIG. 10 is a left side elevational view of FIG. 7;

FIG. 11 is a right side elevational view of FIG. 7;

FIG. 12 is a bottom plan view of FIG. 7;

FIG. 13 is a top plan view of a third embodiment of the airplane;

FIG. 14 is a front elevational view of FIG. 13;

FIG. 15 is a left side elevational view of FIG. 13;

FIG. 16 is a right side elevational view of FIG. 13;

FIG. 17 is a rear elevational view of FIG. 13; and,

FIG. 18 is a bottom plan view of FIG. 13.

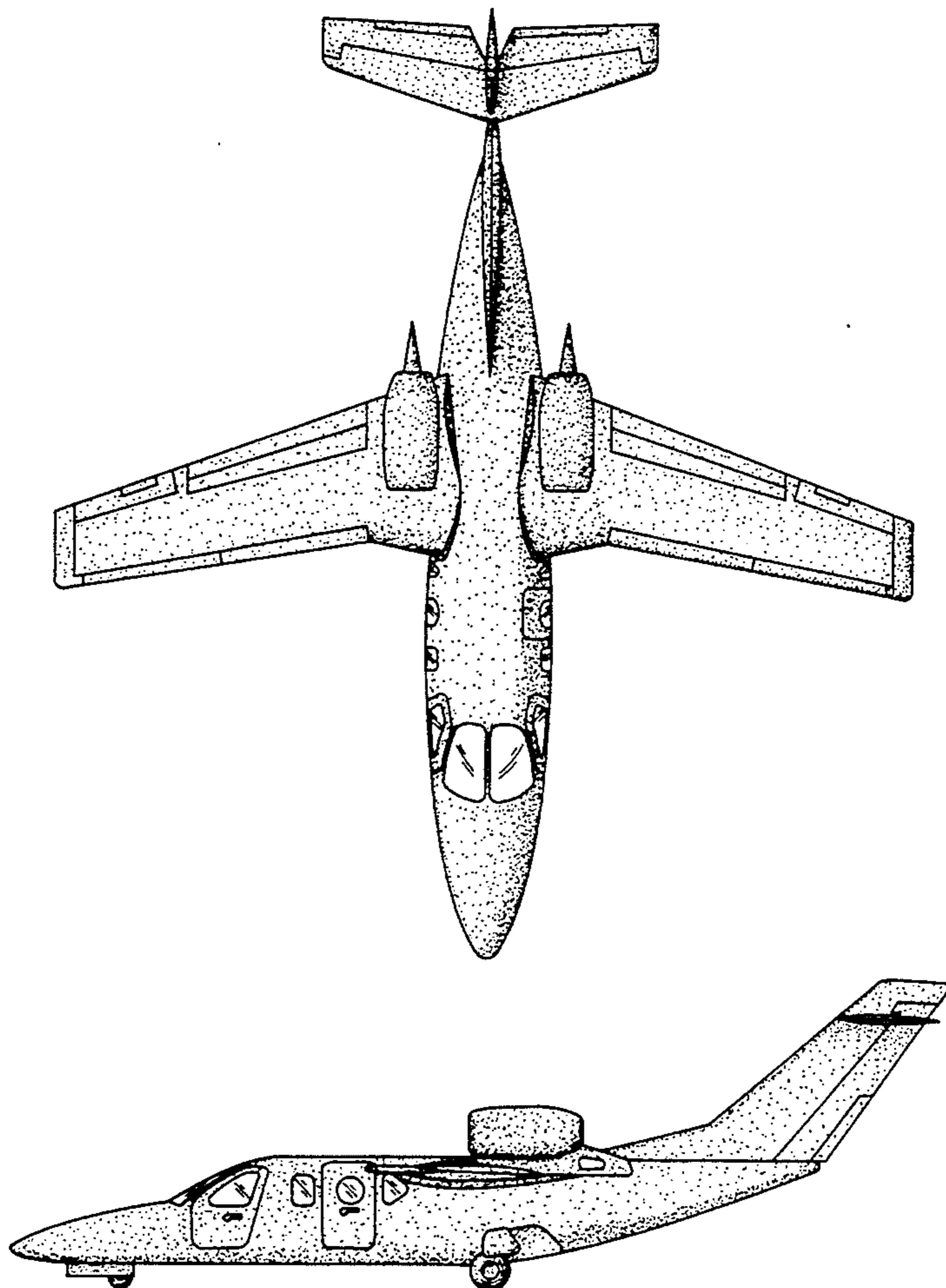

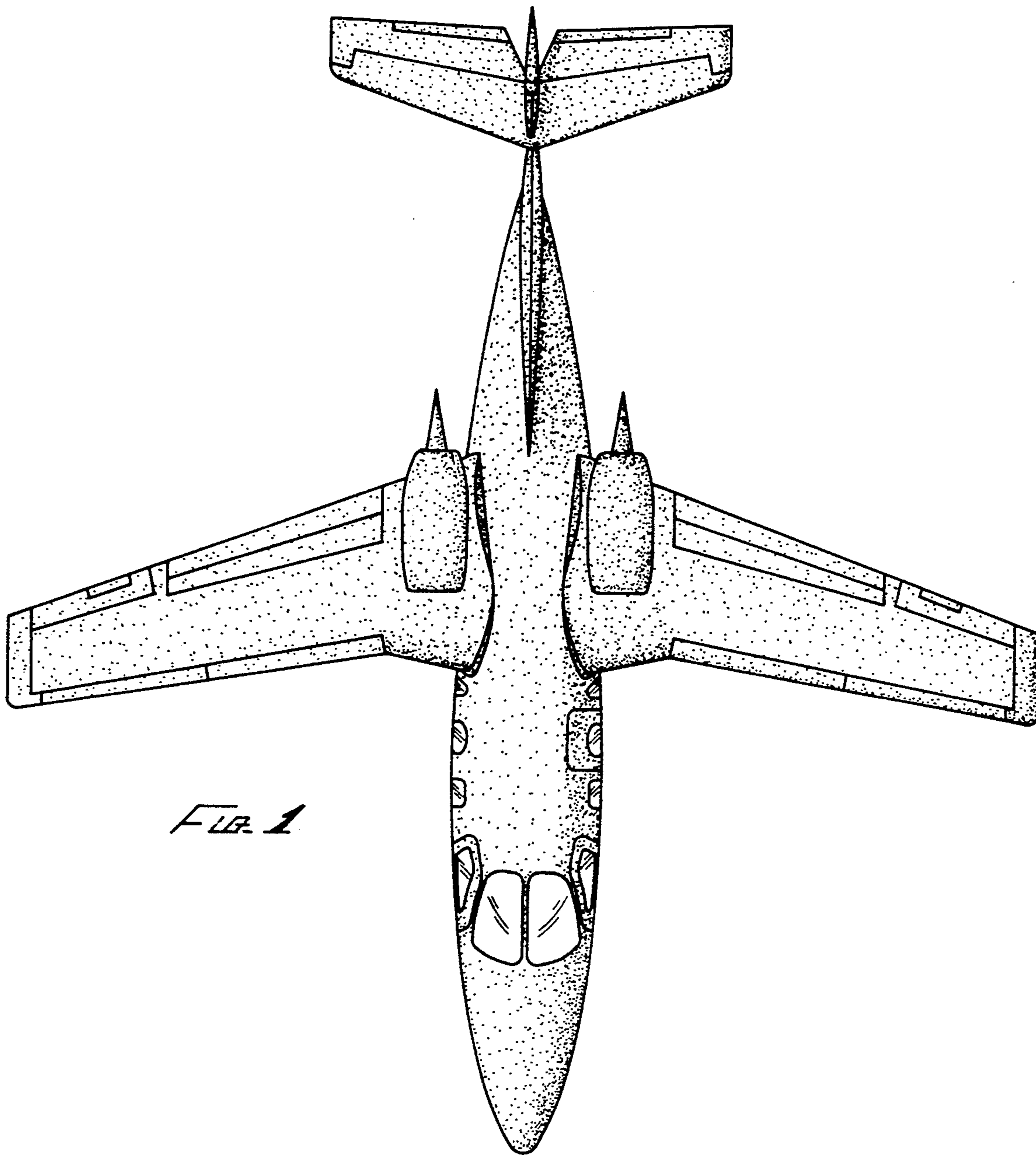

FIG. 1

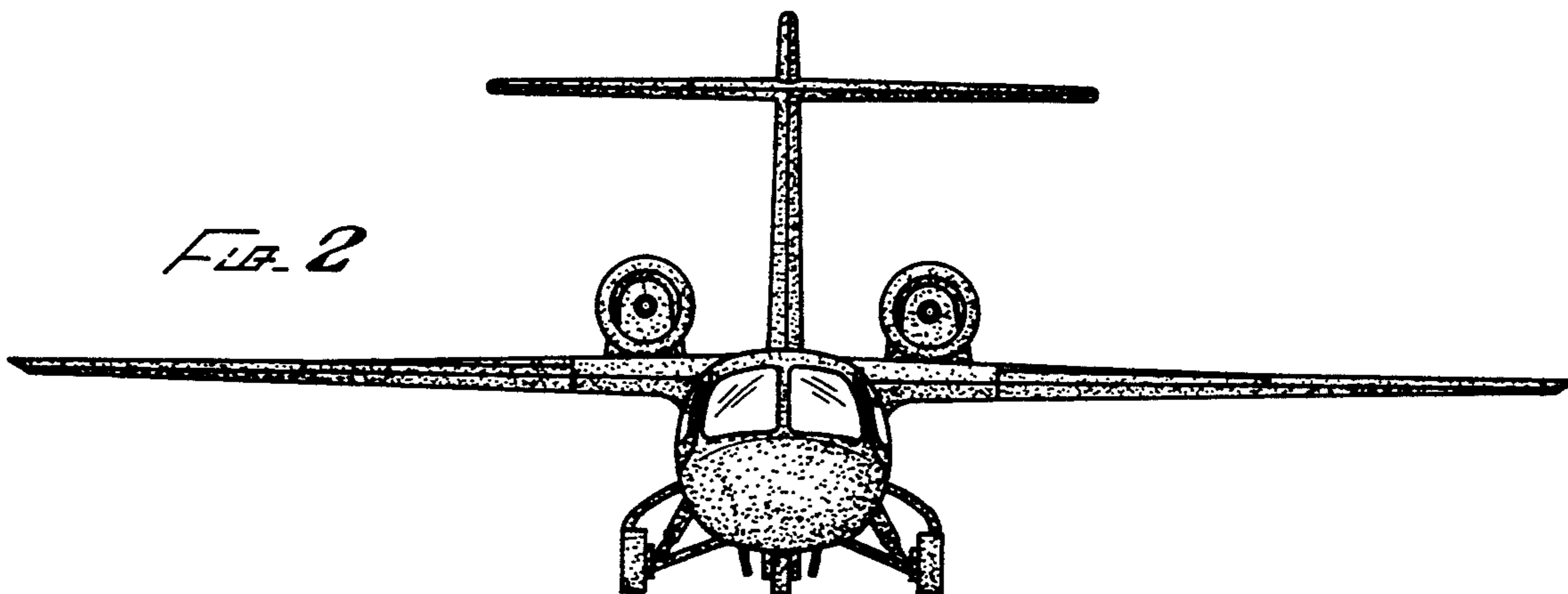
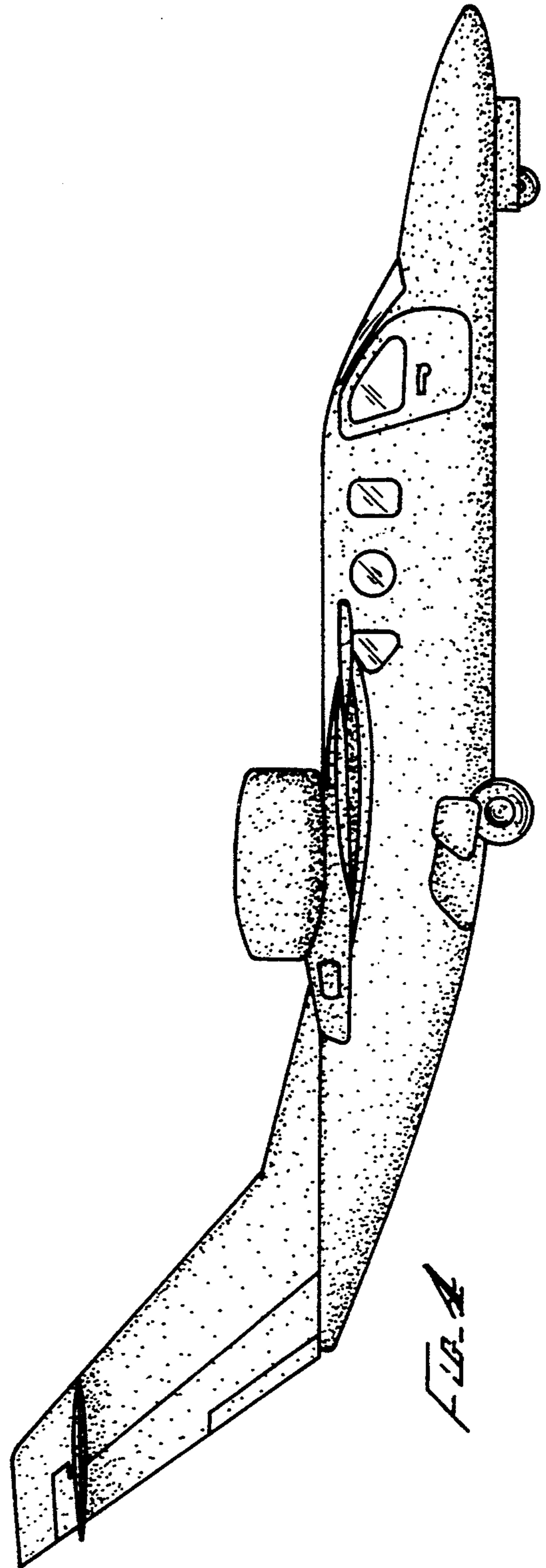
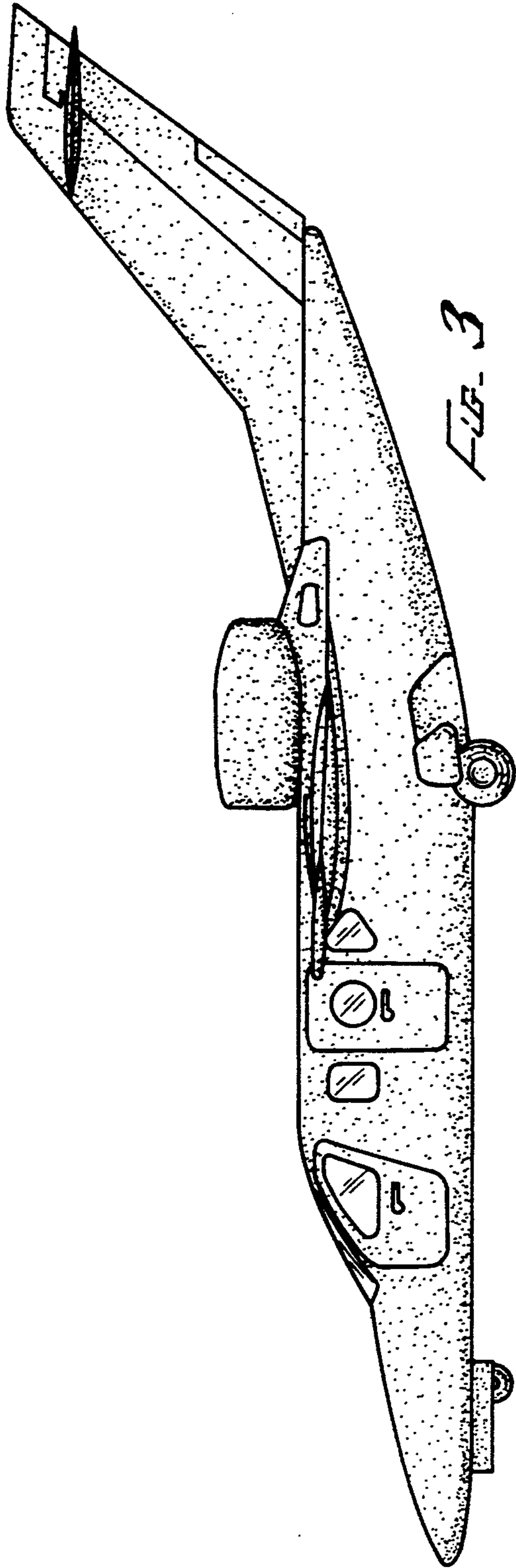

FIG. 2



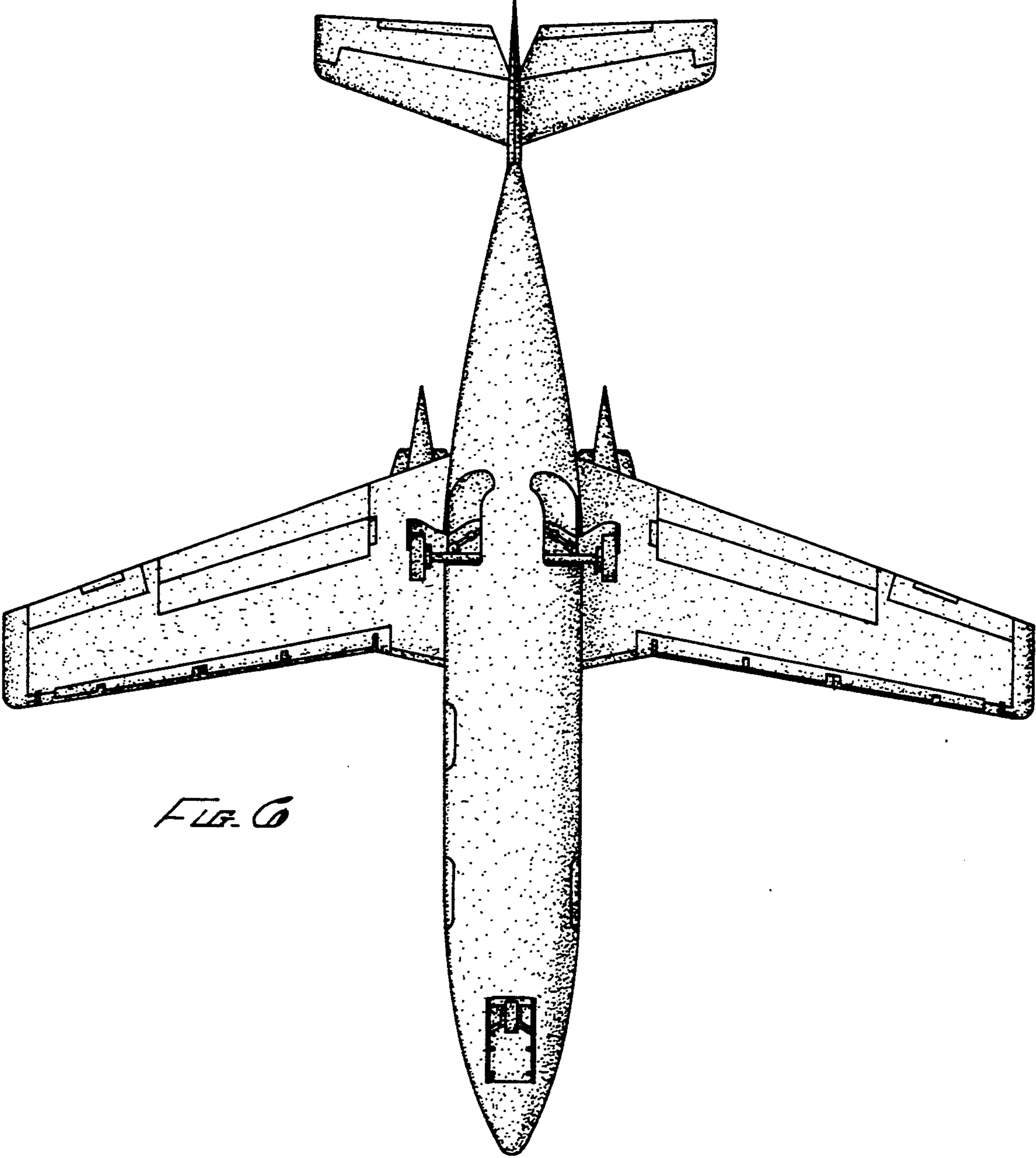

FIG. 6

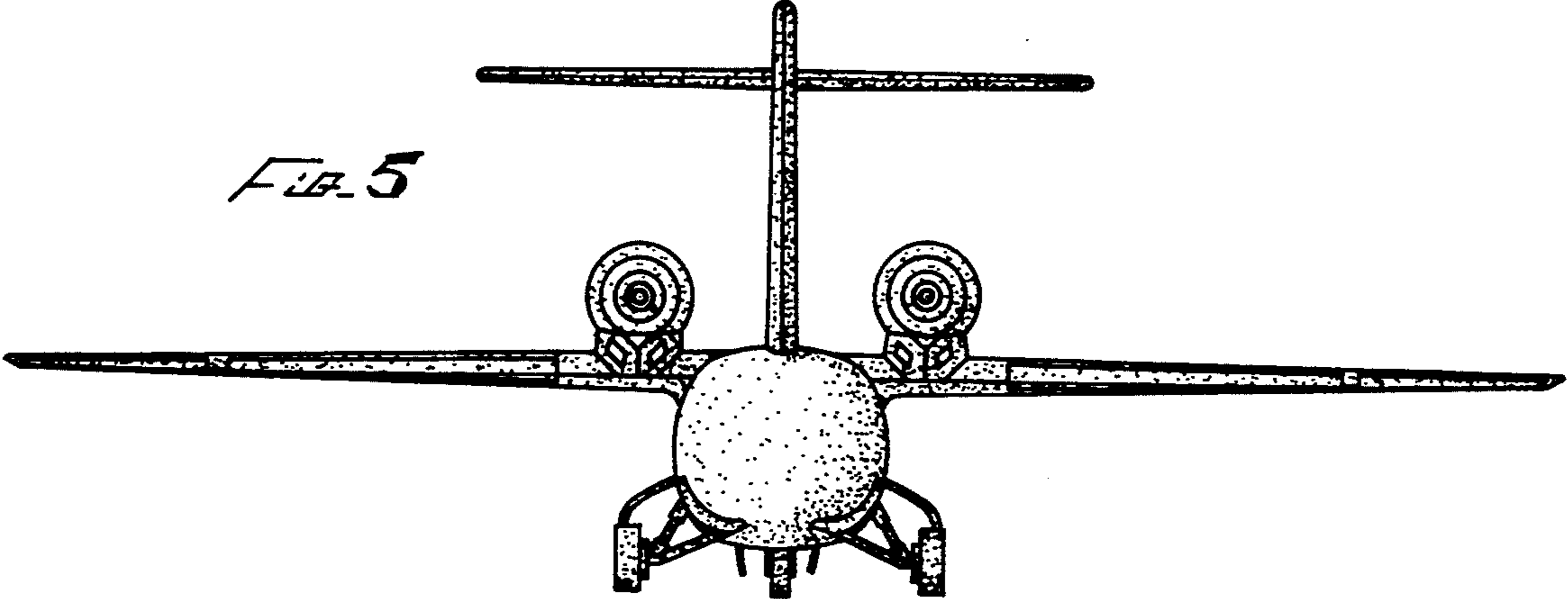

FIG. 5

FIG. 7

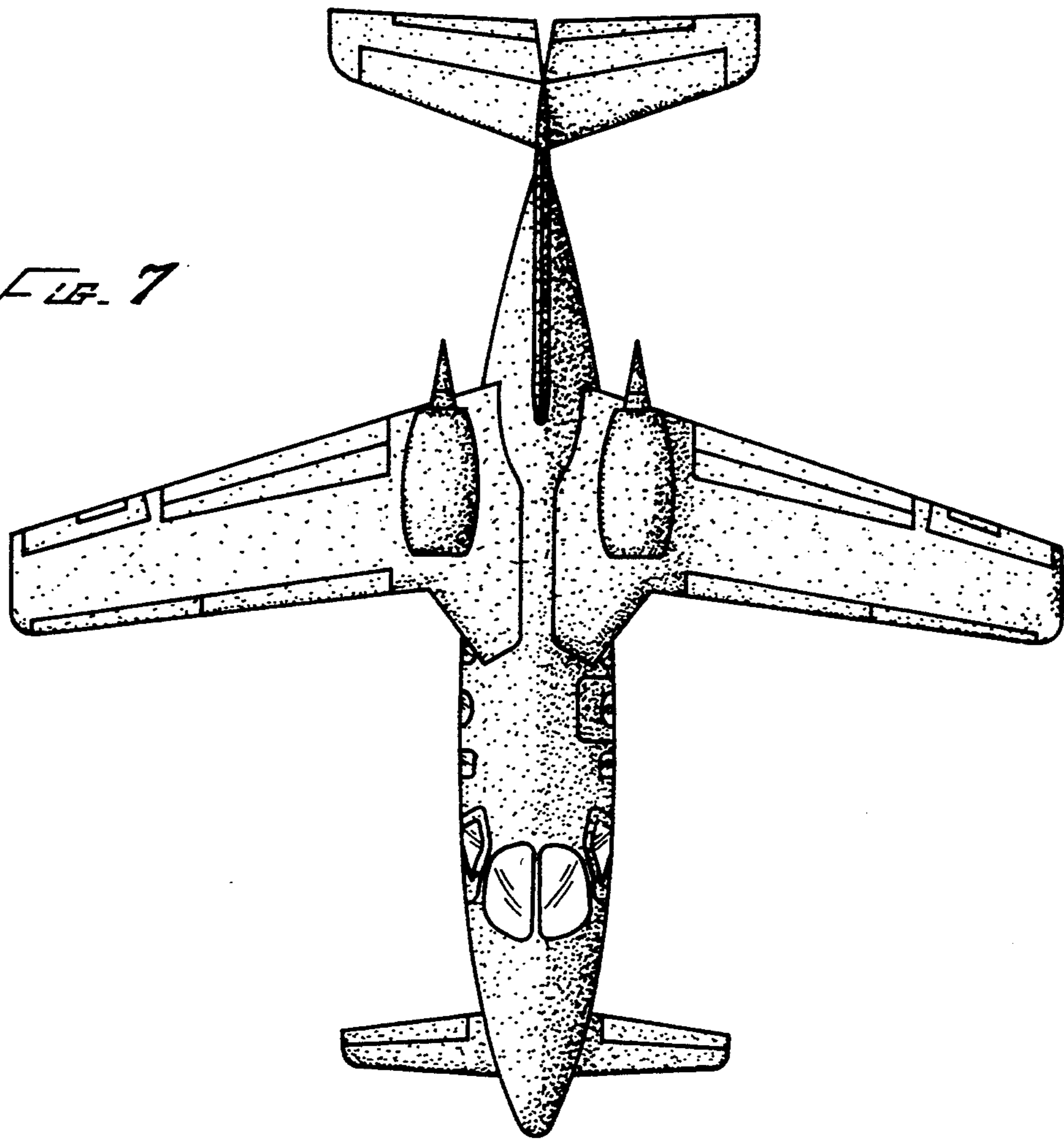

FIG. 8

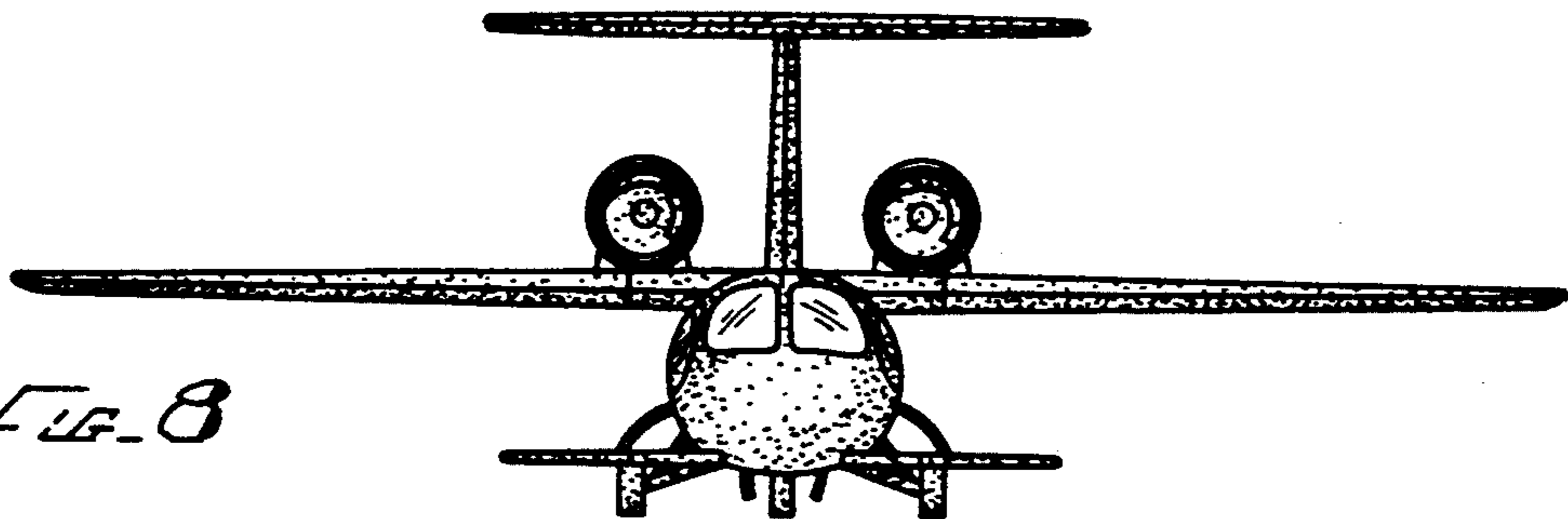
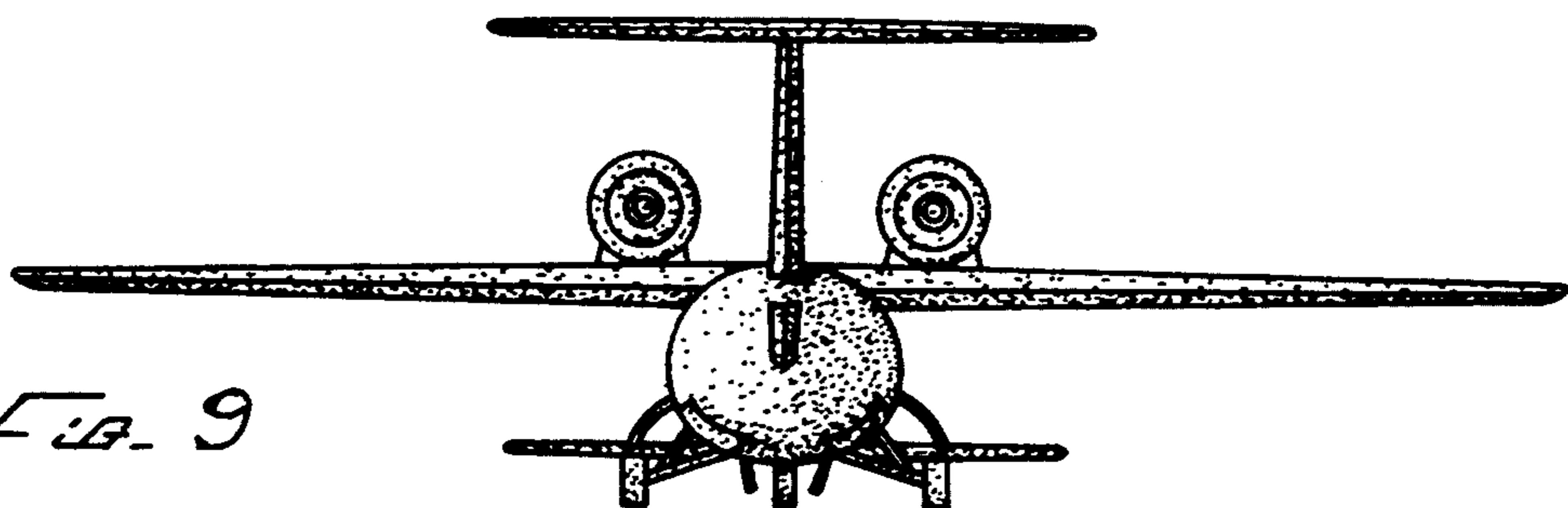
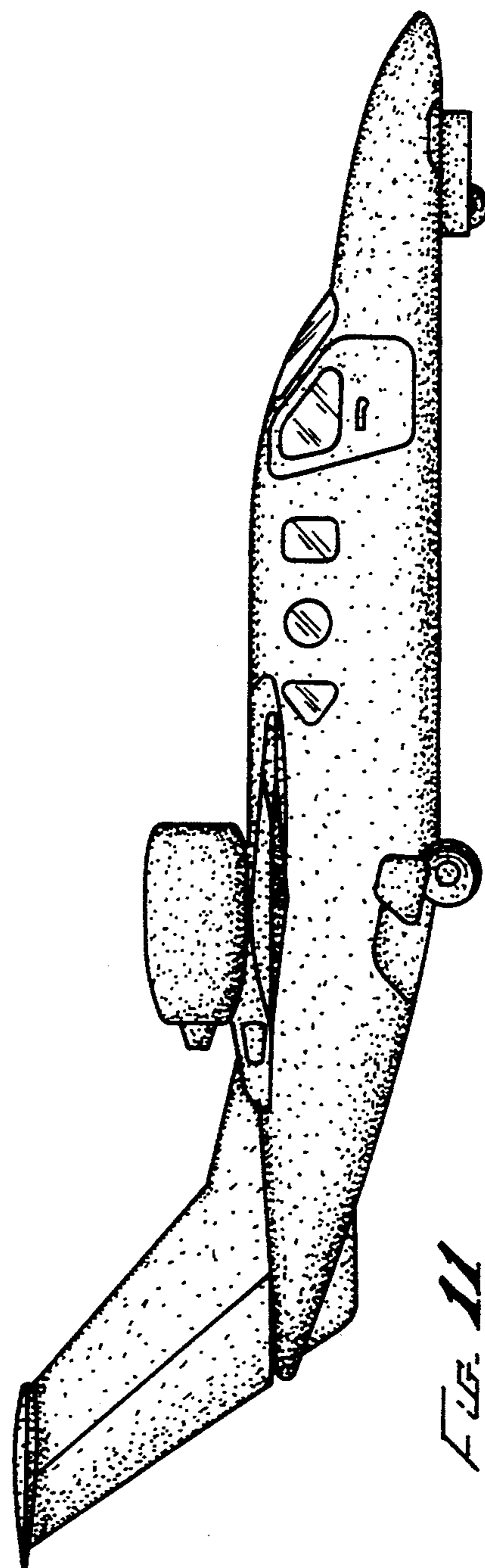
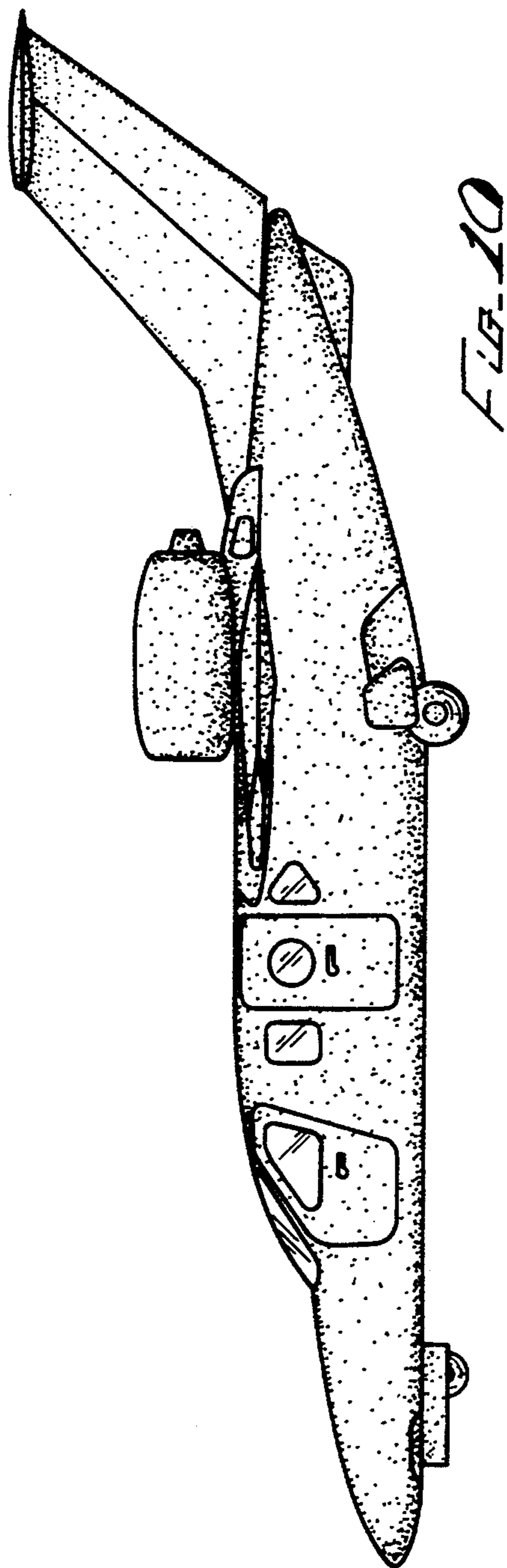

FIG. 9





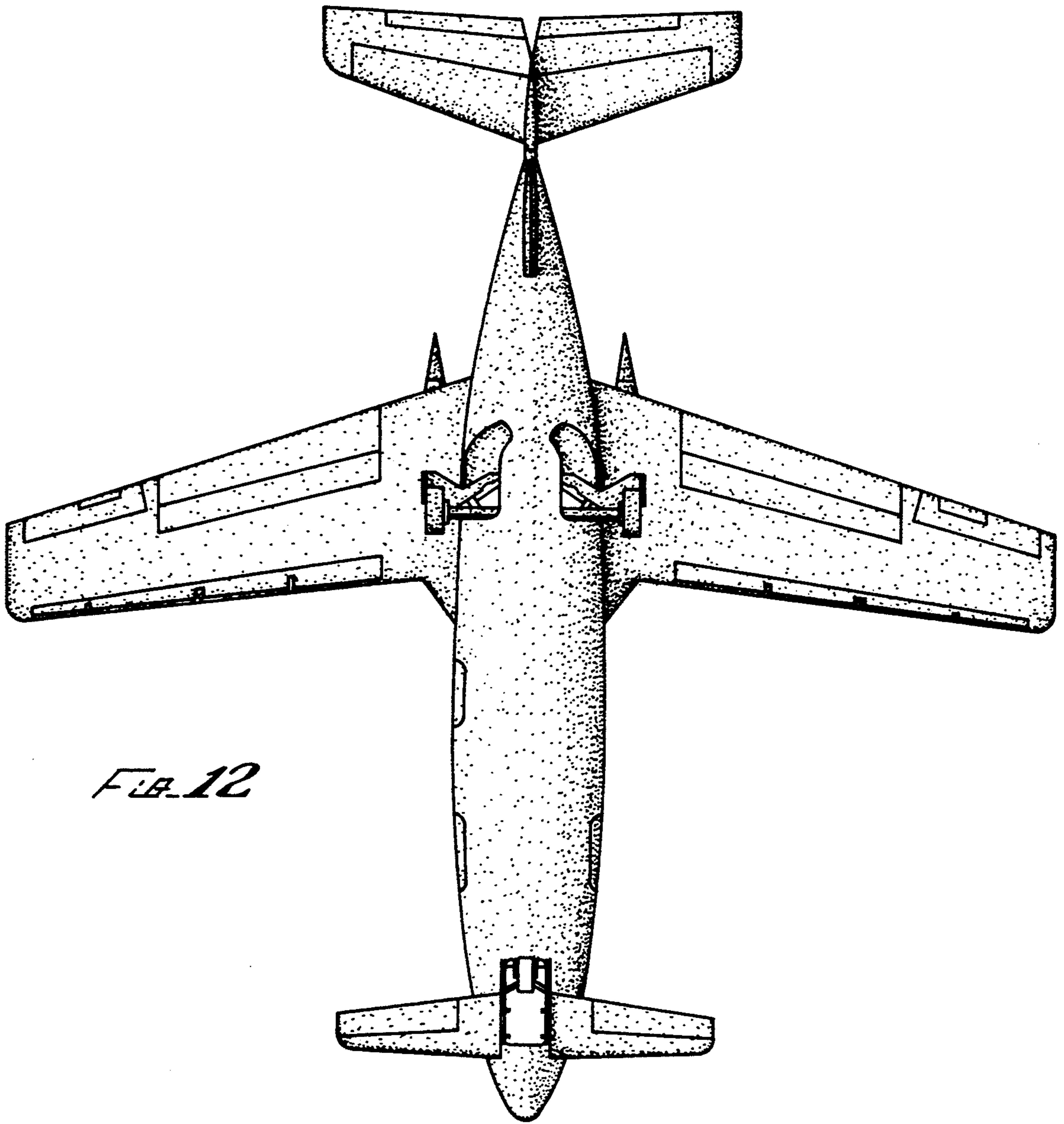

FIG. 12

FIG. 13

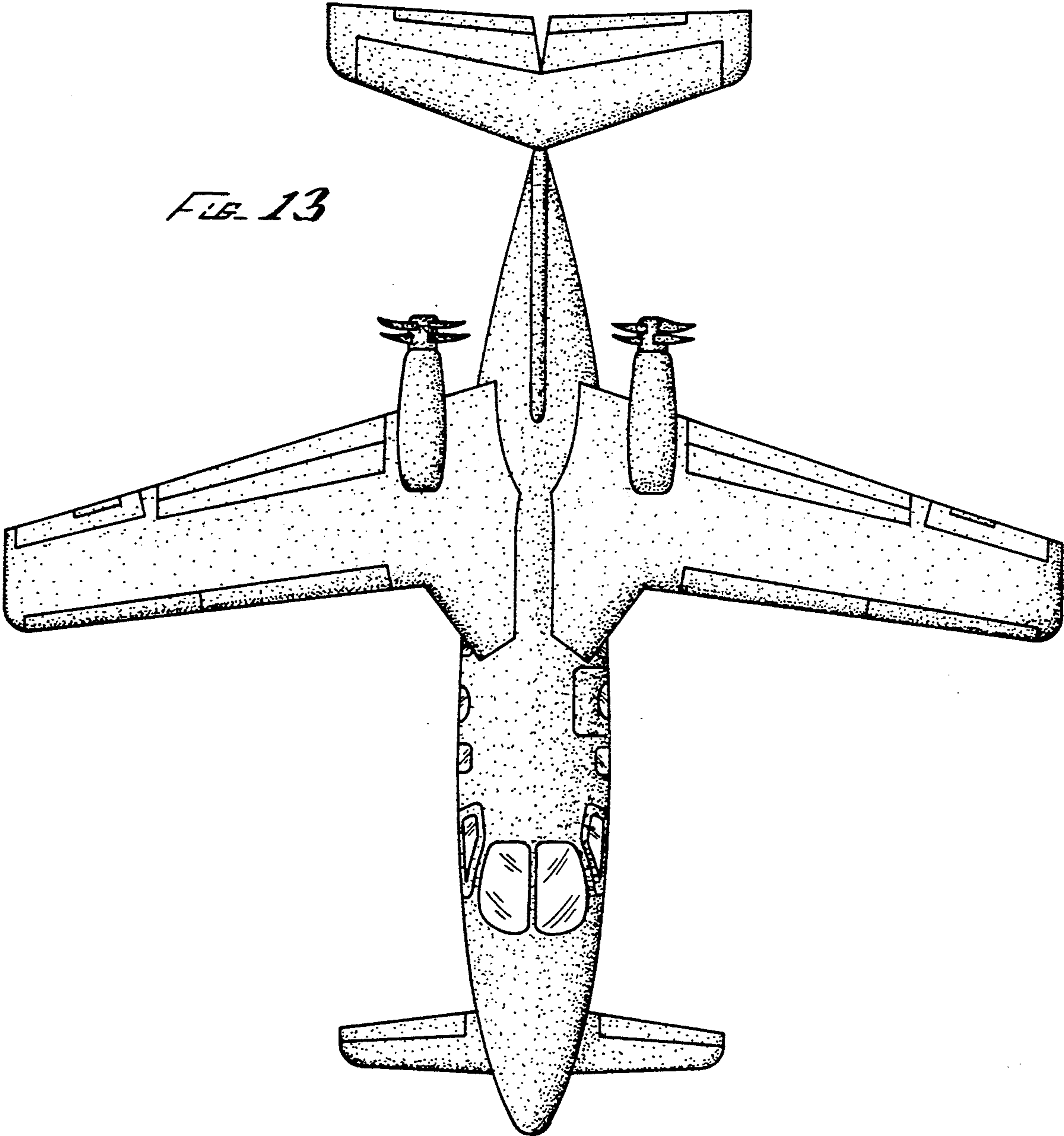

FIG. 14

