



US00D349255S

United States Patent [19]

[11] Patent Number: **Des. 349,255**

Zaleski et al.

[45] Date of Patent: **** Aug. 2, 1994**

[54] **BOAT DISTRESS SIGNAL KIT**

4,901,664 2/1990 Zabrecque 116/DIG. 8
4,917,041 4/1990 Weiswurm .

[76] Inventors: **Nicholas Zaleski; Erick Zaleski**, both of 1 Harris St., Carteret, N.J. 07008

Primary Examiner—Wallace R. Burke
Assistant Examiner—Marcus Jackson
Attorney, Agent, or Firm—Terry M. Gernstein

[**] Term: **14 Years**

[21] Appl. No.: **7,545**

[57] **CLAIM**

[22] Filed: **Apr. 26, 1993**

The ornamental design for a boat distress signal kit, as shown and described.

[52] U.S. Cl. **D10/109**

[58] Field of Search 40/607; 116/DIG. 8, 116/DIG. 9, DIG. 6; 441/30, 40, 41; D10/104, 106, 109, 111, 121

DESCRIPTION

[56] **References Cited**

U.S. PATENT DOCUMENTS

| | | | |
|------------|---------|----------------------|------------|
| D. 313,767 | 1/1991 | Rosebush et al. | D10/109 |
| D. 332,578 | 1/1993 | Gibson | D10/109 |
| 4,295,438 | 10/1981 | Porter | 116/DIG. 8 |
| 4,697,706 | 10/1987 | Schaller . | |
| 4,800,835 | 1/1989 | Mears | 116/DIG. 9 |
| 4,872,414 | 10/1989 | Asquith . | |

FIG. 1 is a front, top and side perspective view of the boat distress signal kit showing our new design in the open condition;
FIG. 2 is a front elevational view thereof;
FIG. 3 is a rear elevational view thereof;
FIG. 4 is a side elevational view thereof, the side opposite being a mirror image of the side shown in FIG. 4;
FIG. 5 is a top plan view thereof;
FIG. 6 is a bottom plan view thereof; and,
FIG. 7 is a top plan view thereof.

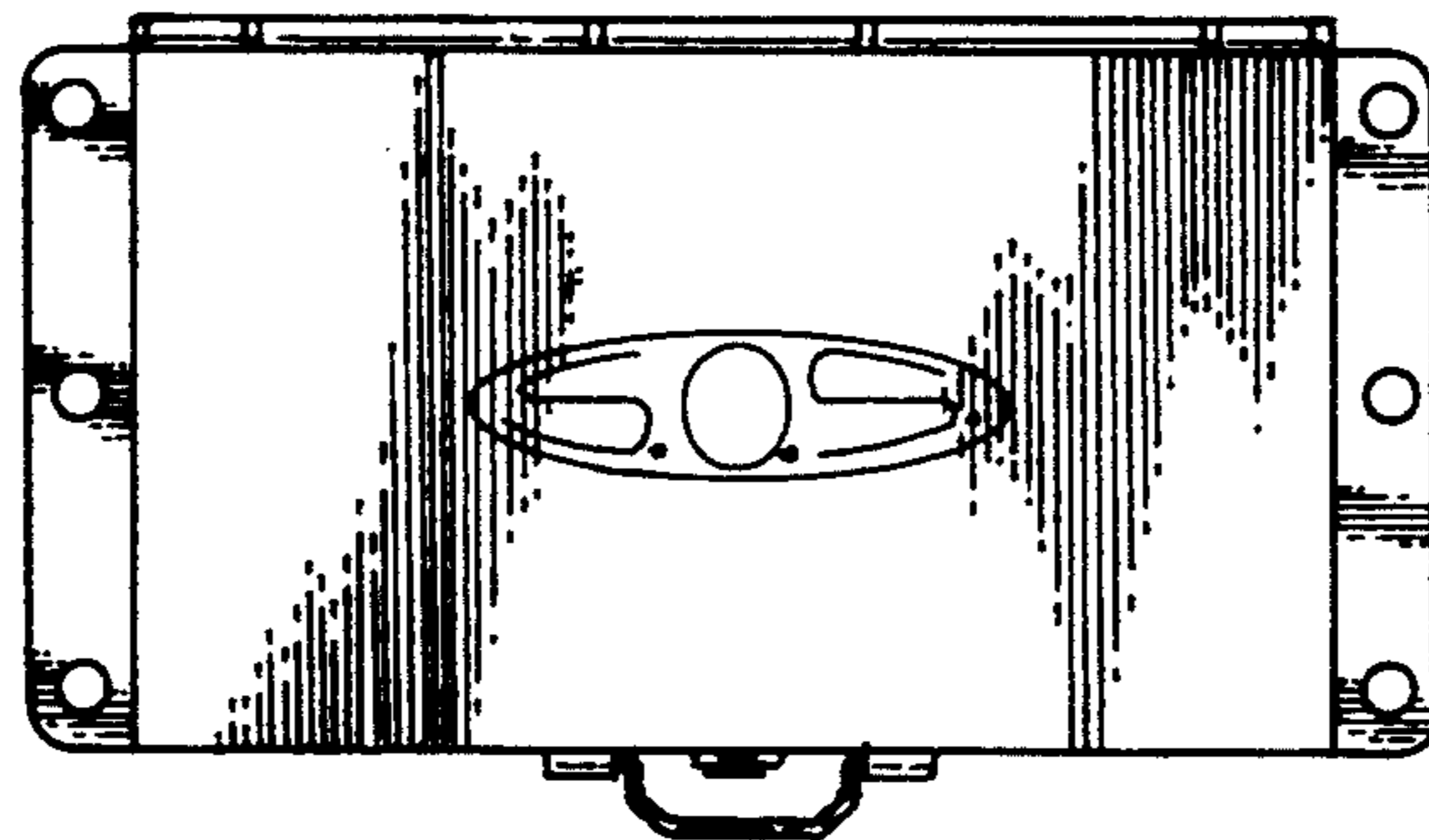
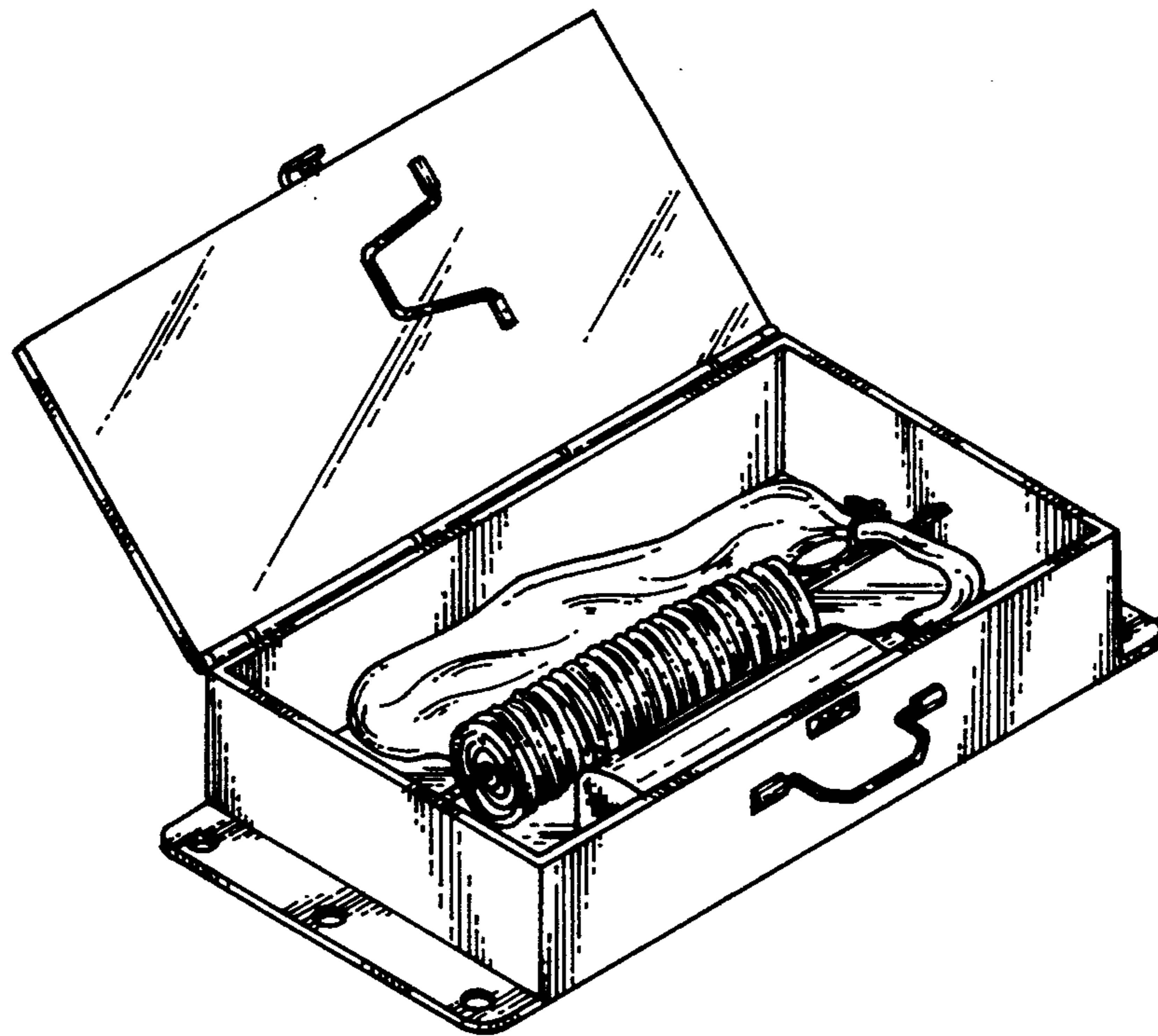

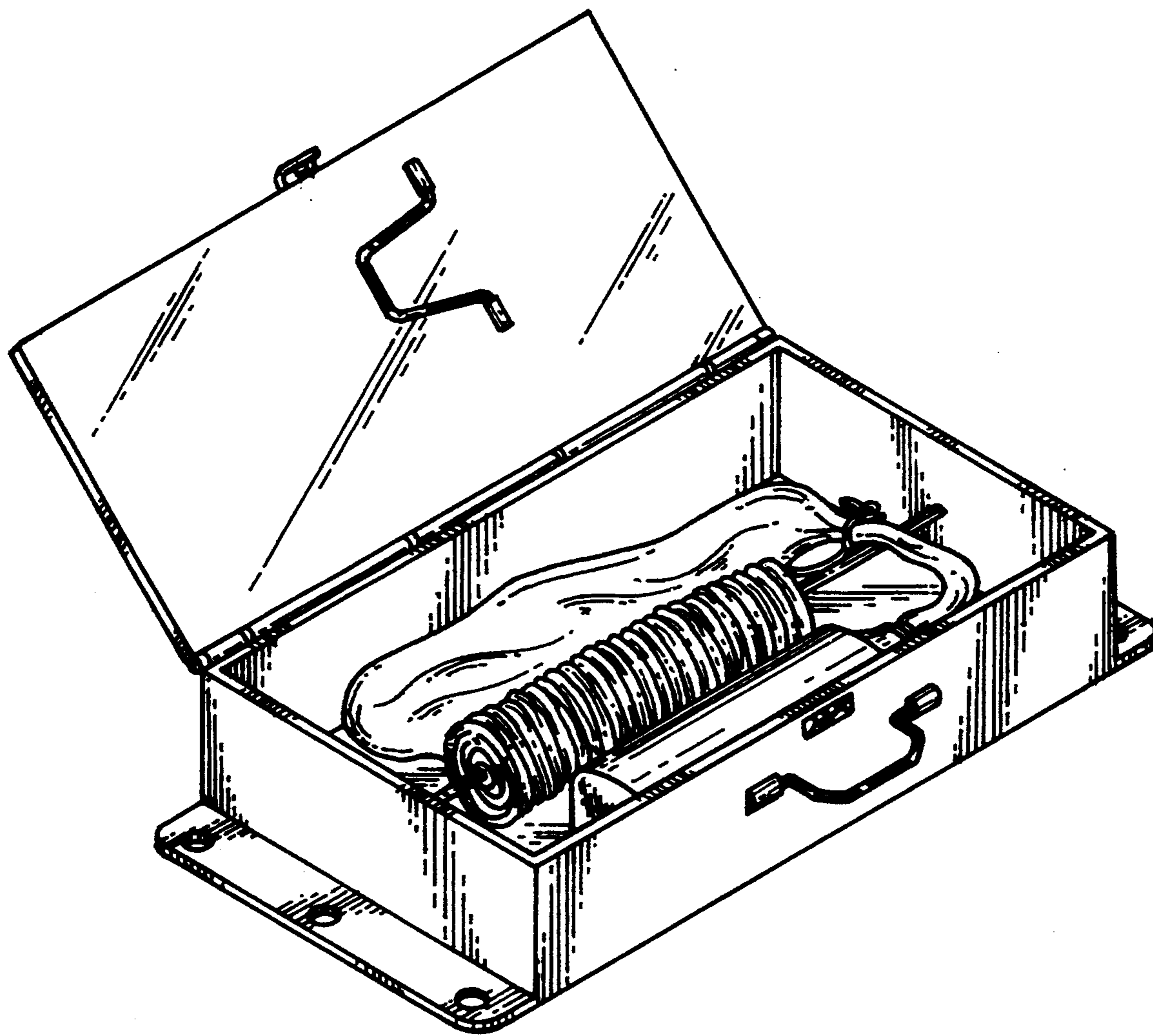

FIG. 1

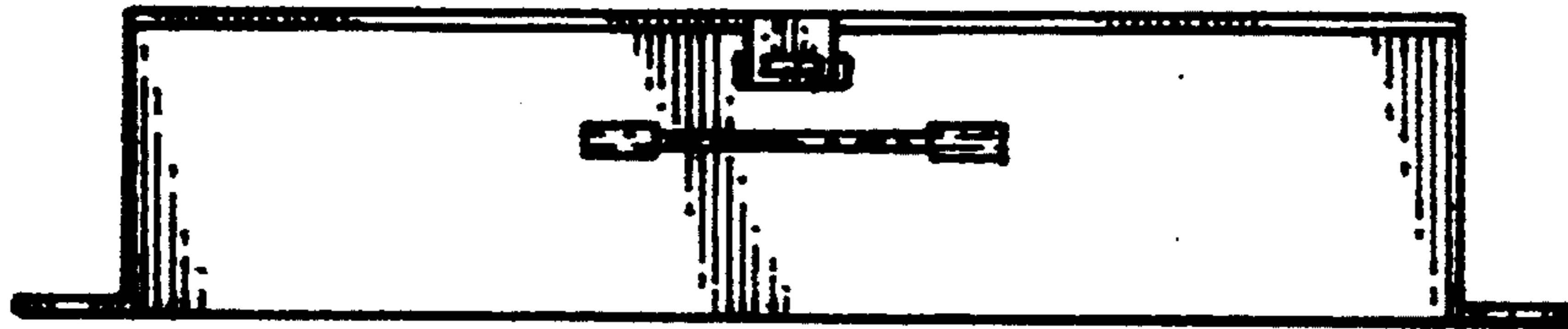

FIG. 2

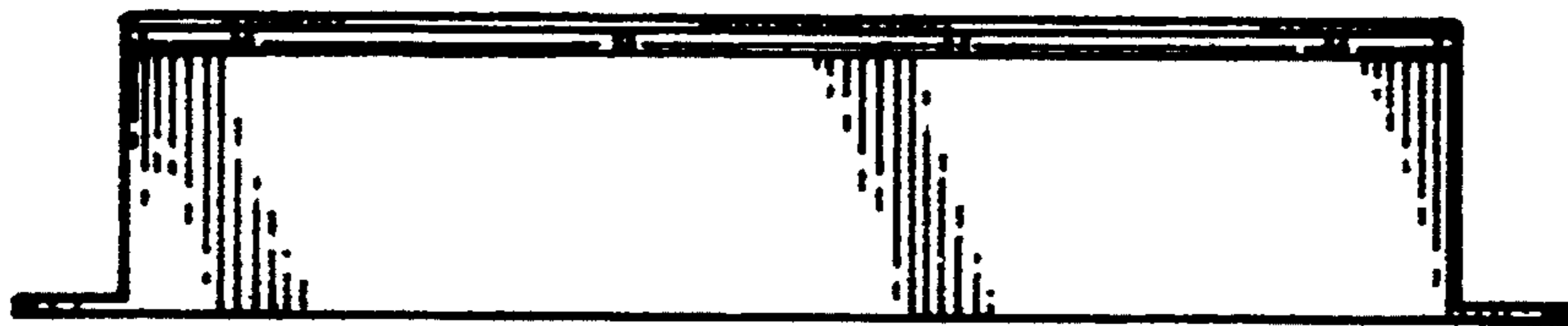

FIG. 3

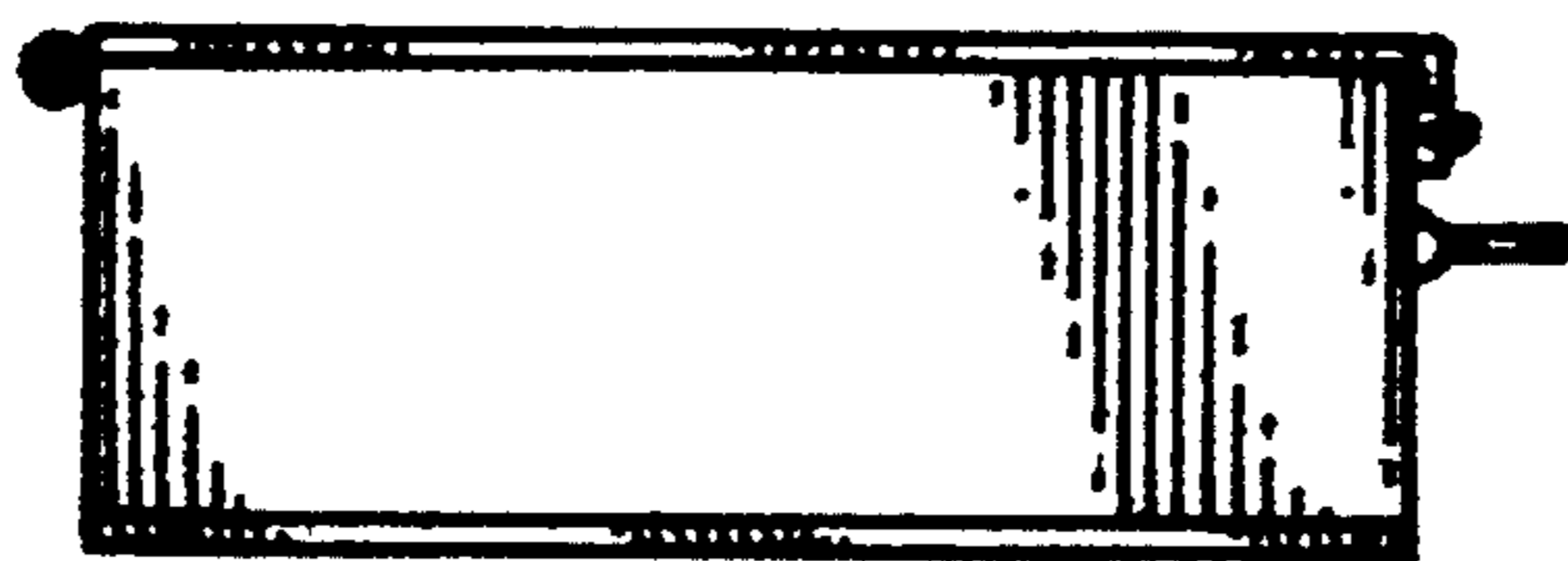

FIG. 4

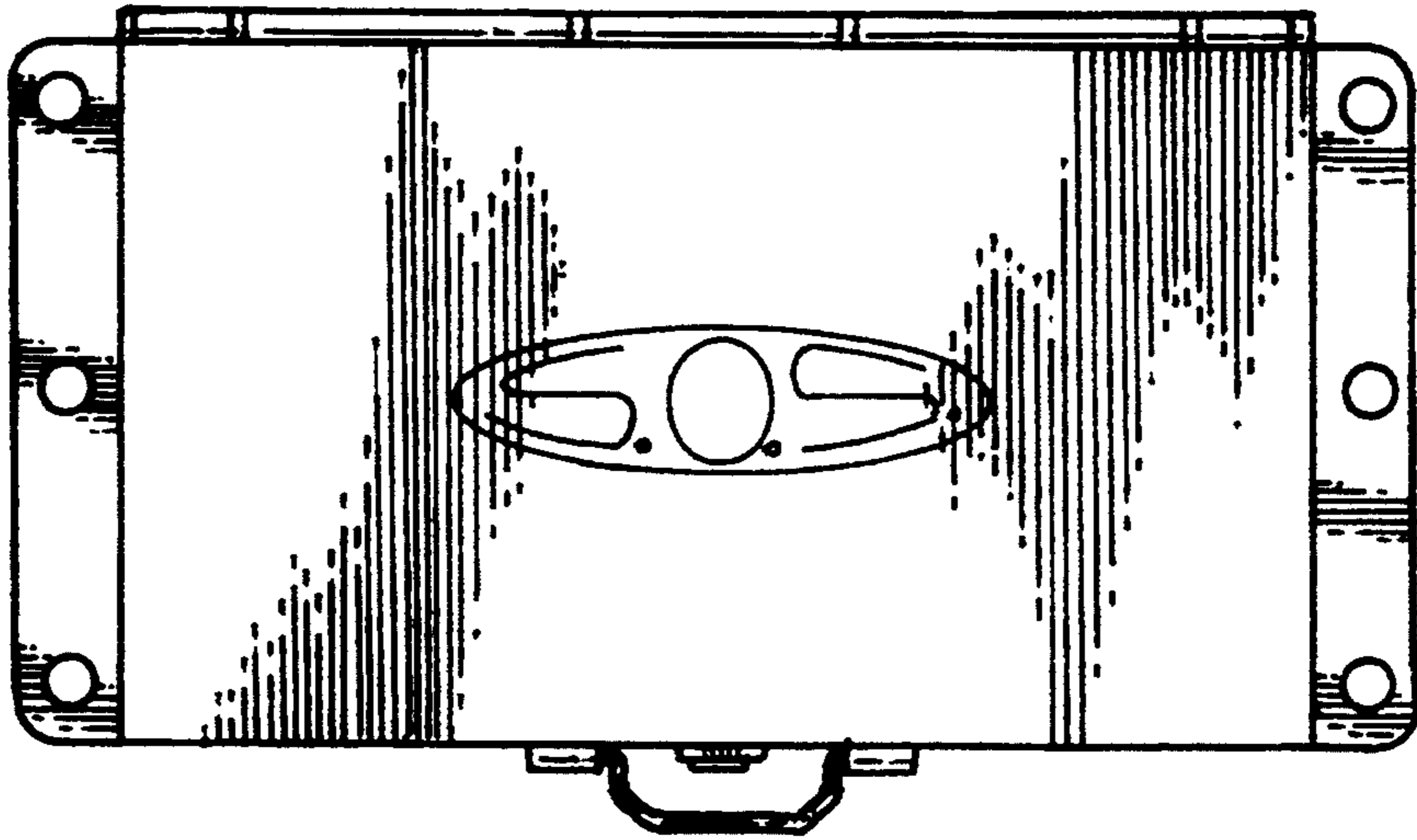

FIG. 5

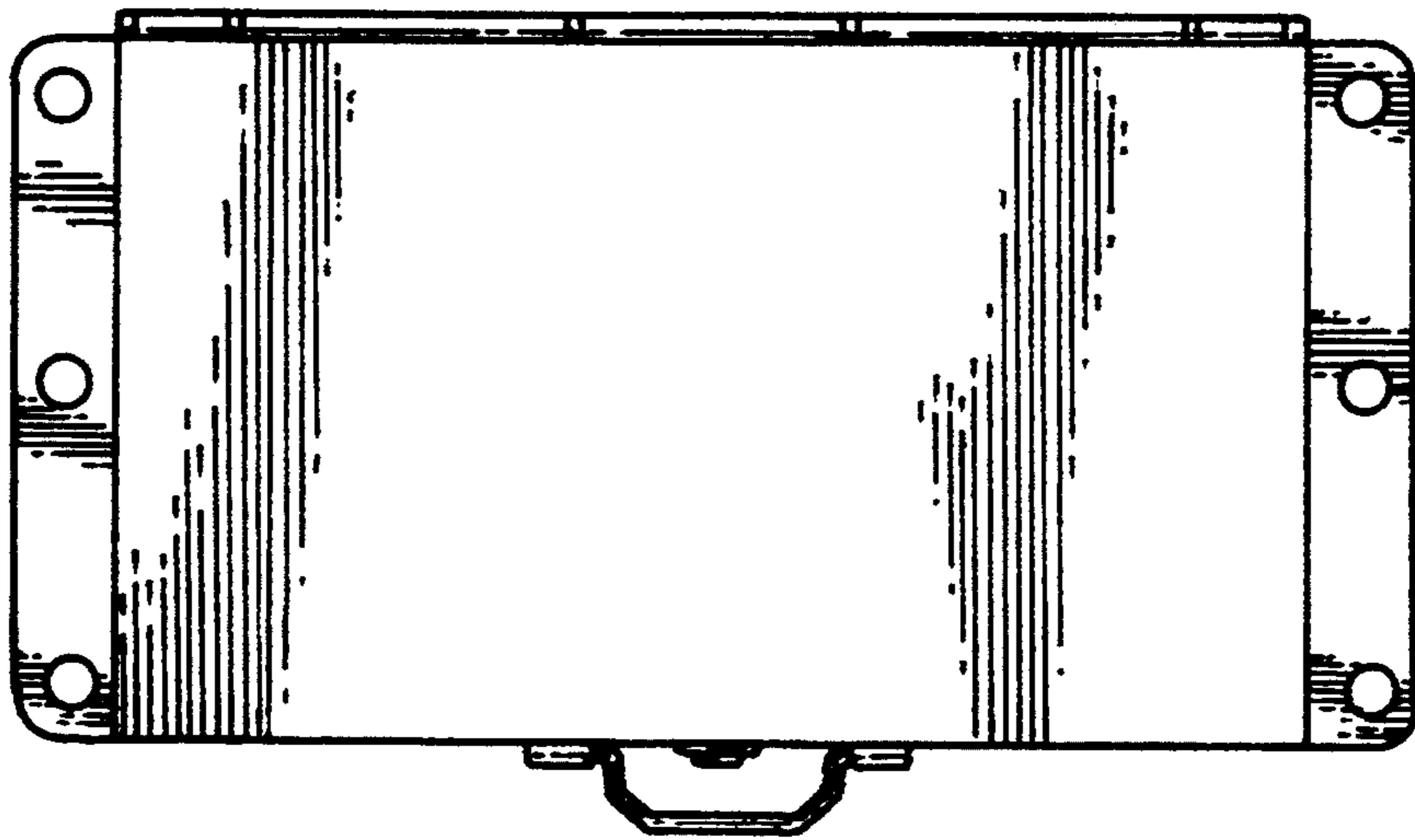

FIG. 6

FIG. 7

