



US00D349089S

United States Patent [19]

[11] Patent Number: **Des. 349,089**

Echazabel et al.

[45] Date of Patent: **** Jul. 26, 1994**

[54] **VEHICLE WHEEL CENTER CAP**

D. 16,467 1/1986 Maris D12/207
D. 184,573 3/1959 Lyon D12/204

[75] Inventors: **Alberto Echazabel**, Hialeah Gardens, Fla.; **Claudio Bernoni**, Albano Terma, Italy

Primary Examiner—James M. Gandy
Attorney, Agent, or Firm—Longacre & White

[73] Assignee: **Motoring Accessories, Inc.**, Miami, Fla.

[57] **CLAIM**

[**] Term: **14 Years**

The ornamental design for a vehicle wheel center cap, as shown and described.

[21] Appl. No.: **4,109**

DESCRIPTION

[22] Filed: **Jan. 27, 1993**

FIG. 1 is a perspective view of a vehicle wheel center cap showing our new design in position of use on a wheel which is illustrated in broken lines for illustrative purposes only and forms no part of the claimed design; FIG. 2 is an enlarged front elevational view of the vehicle wheel center cap shown in FIG. 1; FIG. 3 is an enlarged back elevational view of the vehicle wheel center cap shown in FIG. 1; and, FIG. 4 is an enlarged elevational view of the vehicle wheel center cap shown in FIG. 1.

[52] U.S. Cl. **D12/213**

[58] Field of Search 301/37.1, 108.1, 108.2;
D12/204, 207, 213

[56] **References Cited**

U.S. PATENT DOCUMENTS

D. 7,392 4/1874 Rowe D12/207
D. 16,430 12/1885 Maris D12/207

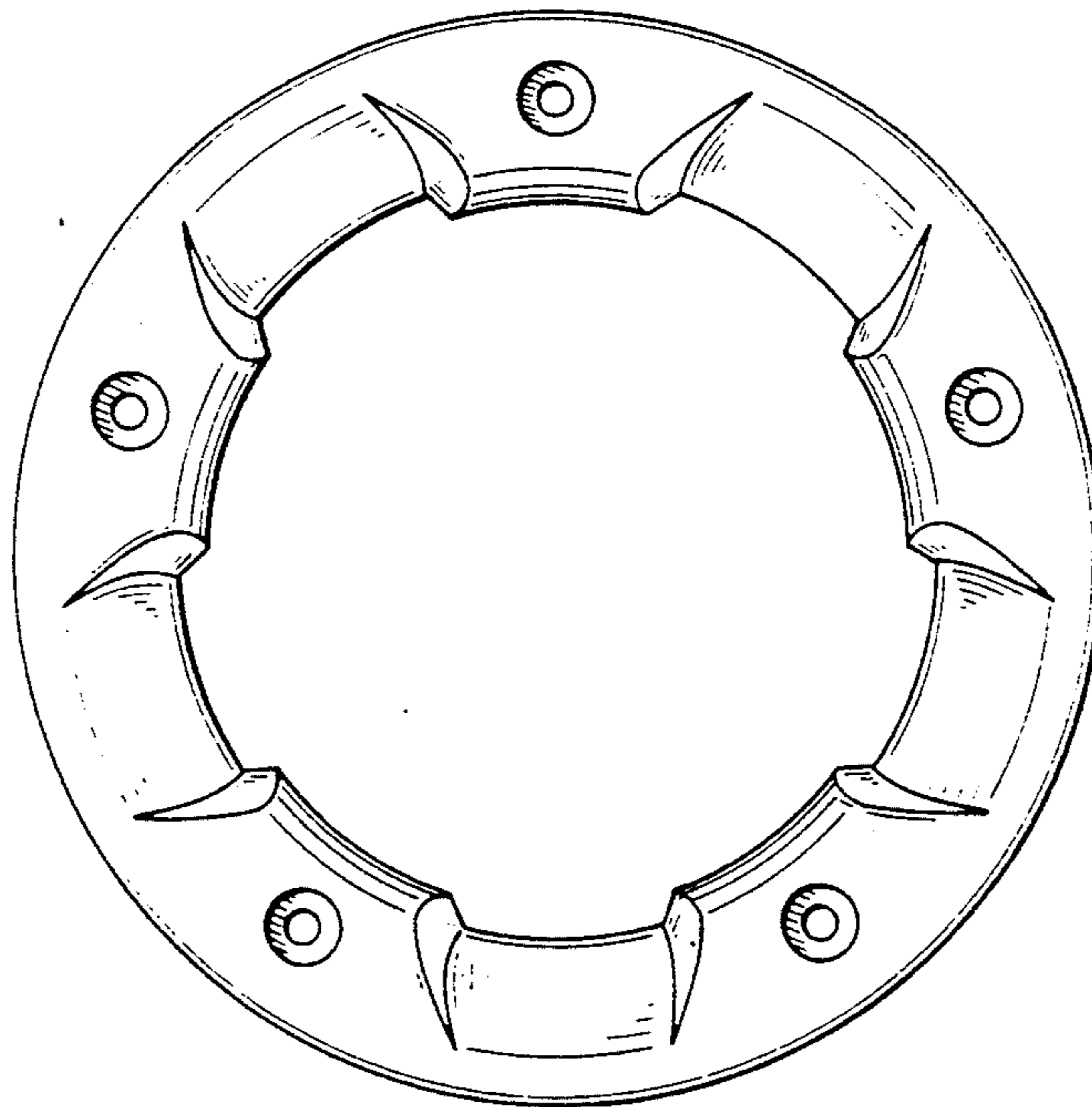

FIG. 1

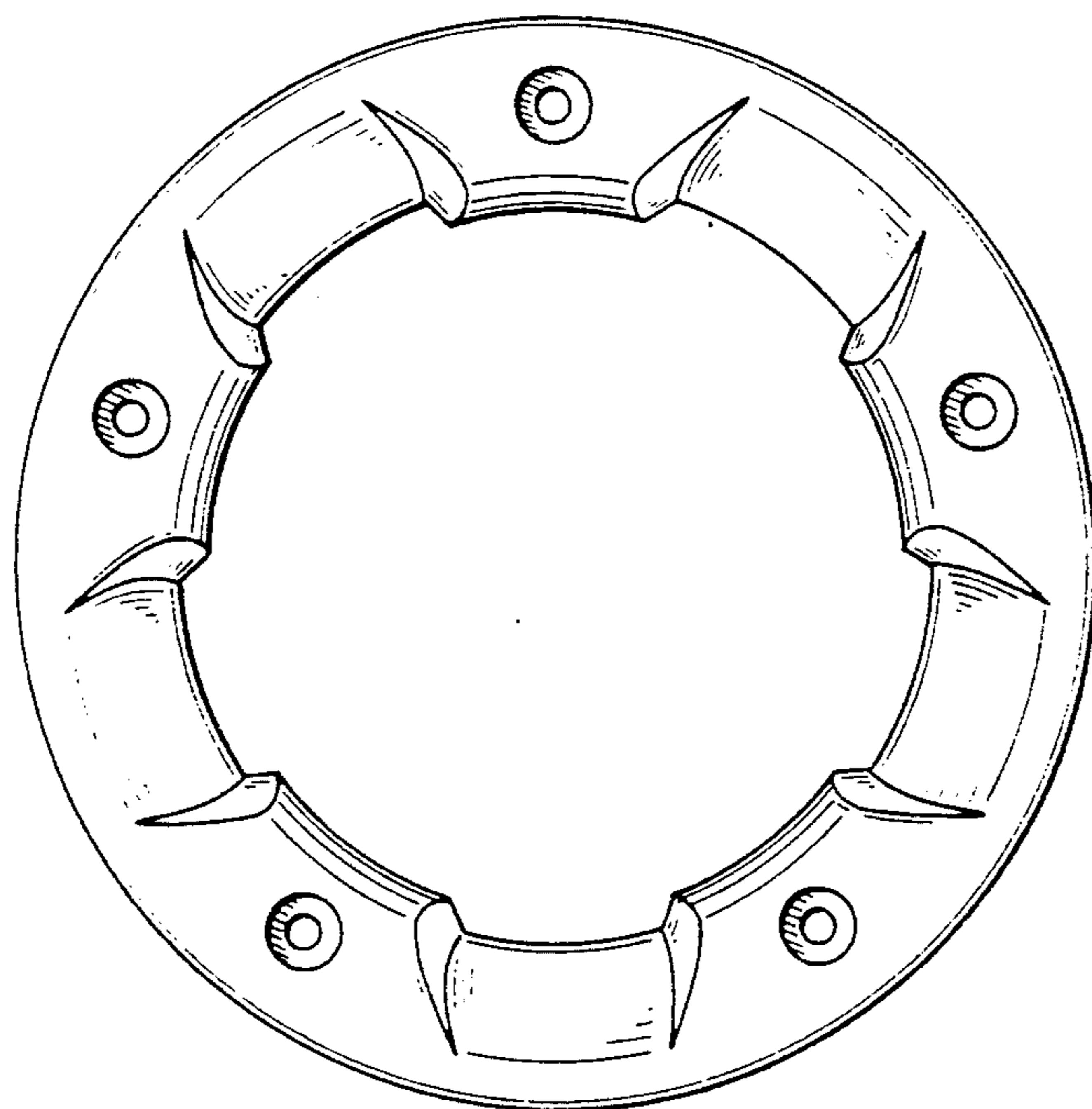
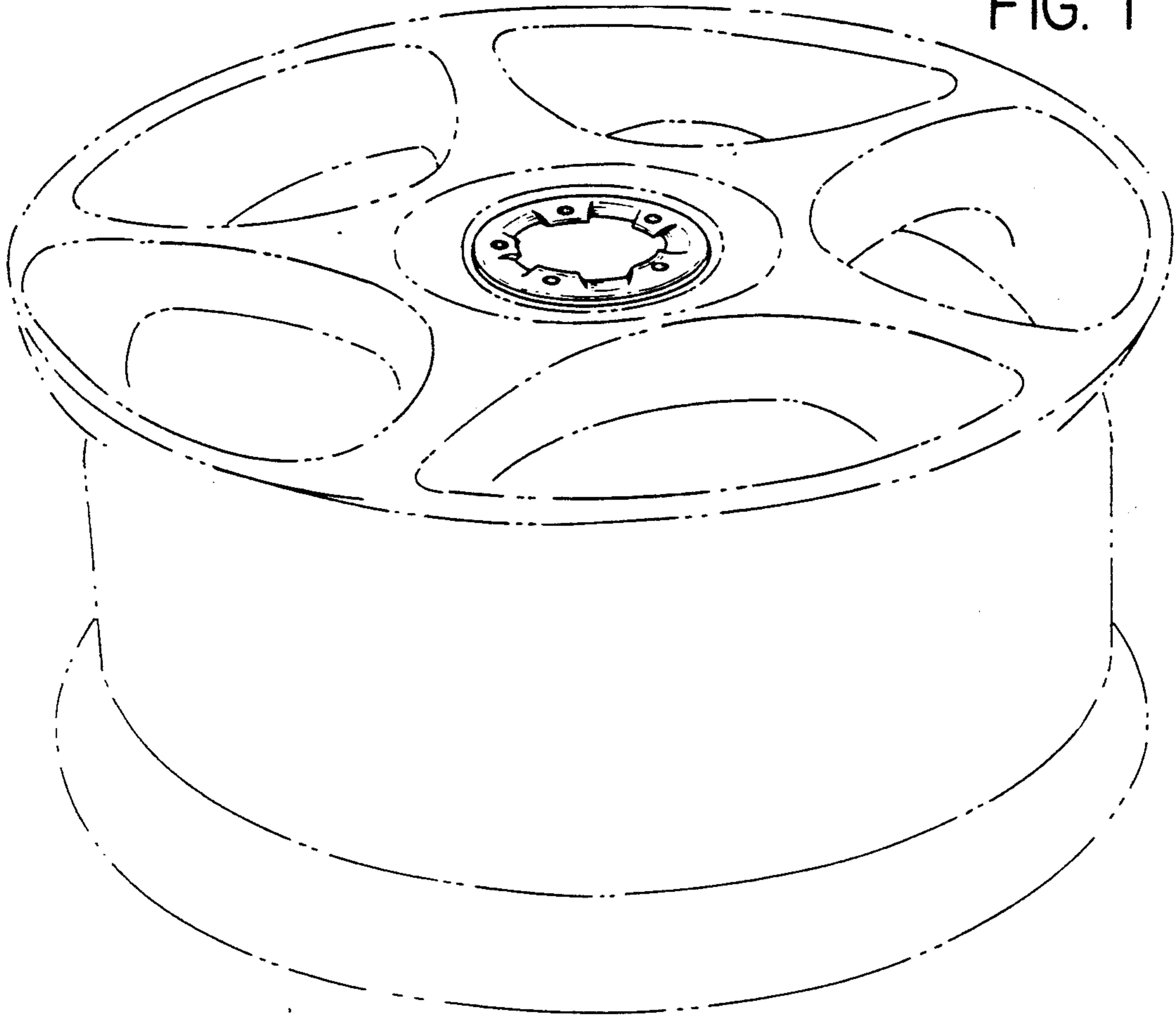

FIG. 2

FIG. 3

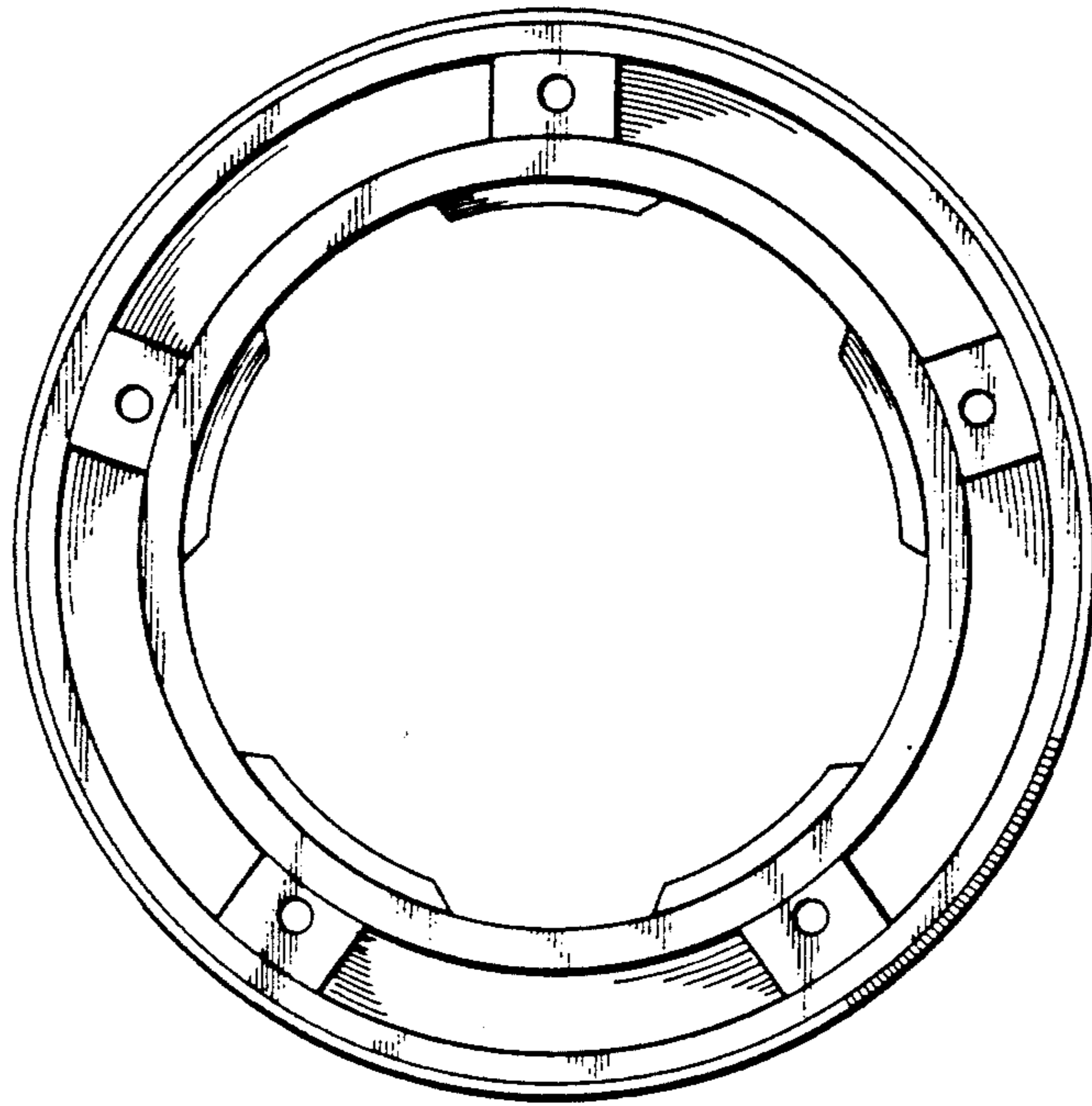

FIG. 4