



US00D349068S

# United States Patent [19]

Naganuma

[11] Patent Number: **Des. 349,068**

[45] Date of Patent: **\*\* Jul. 26, 1994**

## [54] LOAD SENSING DEVICE

[75] Inventor: **Mikio Naganuma**, Yokohama, Japan

[73] Assignee: **TEAC Corporation**, Tokyo, Japan

[\*\*] Term: **14 Years**

[21] Appl. No.: **5,608**

[22] Filed: **Mar. 8, 1993**

### [30] Foreign Application Priority Data

Sep. 10, 1992 [JP] Japan ..... 4-27018

[52] U.S. Cl. .... **D10/83**

[58] Field of Search ..... 73/431, 774, 779, 856,  
73/862.338, 862.339, 862.627, 862.628;  
D10/83, 84, 85, 86, 89, 94

### [56] References Cited

#### U.S. PATENT DOCUMENTS

D. 340.875 11/1993 Castagnoli ..... D10/83  
4,827,764 5/1989 Hwang ..... D10/86

## OTHER PUBLICATIONS

Cole-Palmer, Pressure transducer; ©1991-1992; p. 752.

Catalogue of Transducers of TEAC Instruments Corporation, Sep. 1989.

*Primary Examiner*—Alan P. Douglas

*Assistant Examiner*—Antoine D. Davis

*Attorney, Agent, or Firm*—Ladas & Parry

## [57] CLAIM

The ornamental design for load sensing device, as shown and described.

## DESCRIPTION

FIG. 1 is a perspective view of a load sensing device showing my new design;

FIG. 2 is a front elevational view thereof;

FIG. 3 is a rear elevational view thereof;

FIG. 4 is a top plan view thereof;

FIG. 5 is a bottom plan view thereof;

FIG. 6 is a left side elevational view thereof; and,

FIG. 7 is right side elevational view thereof.

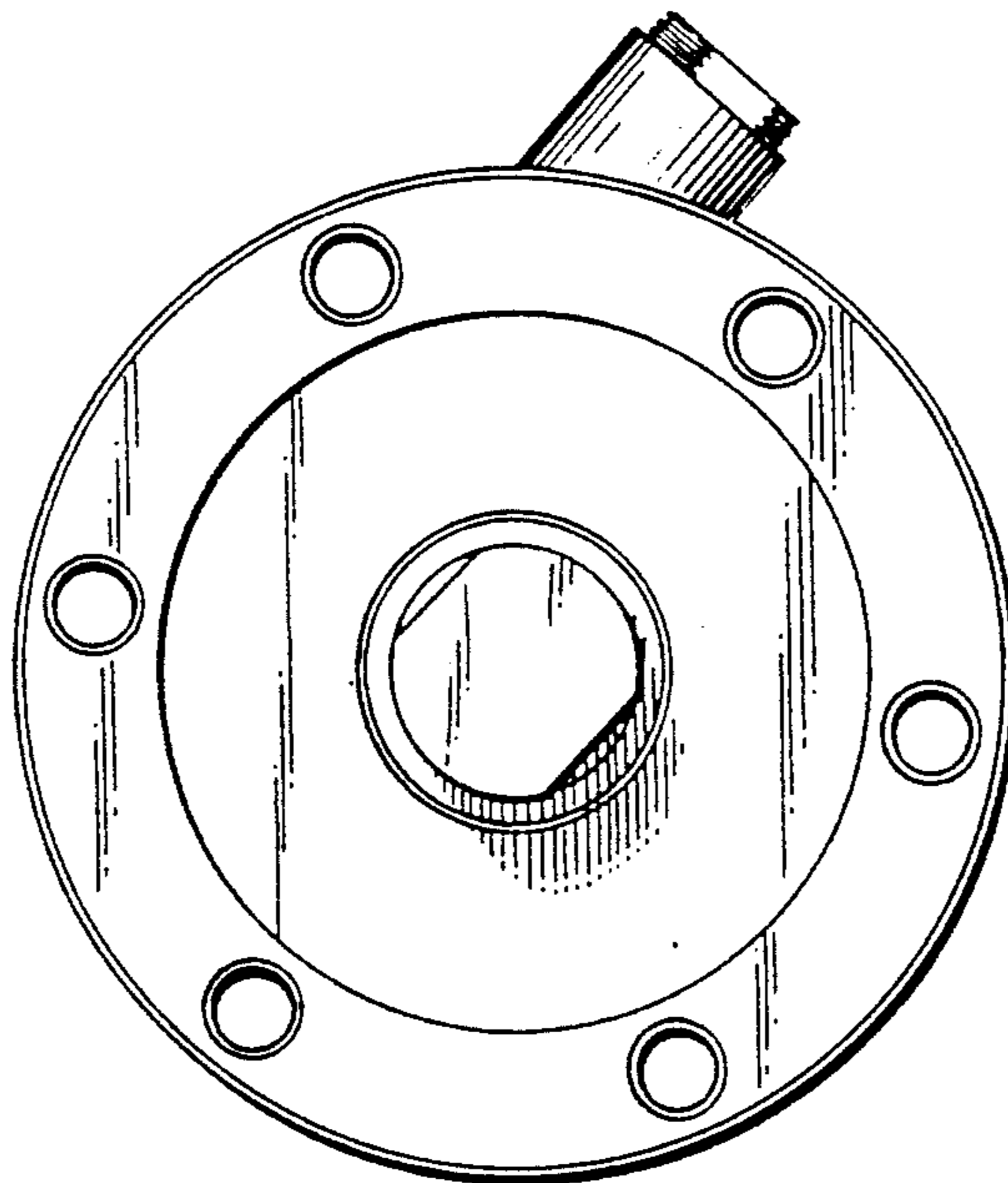

FIG. 1

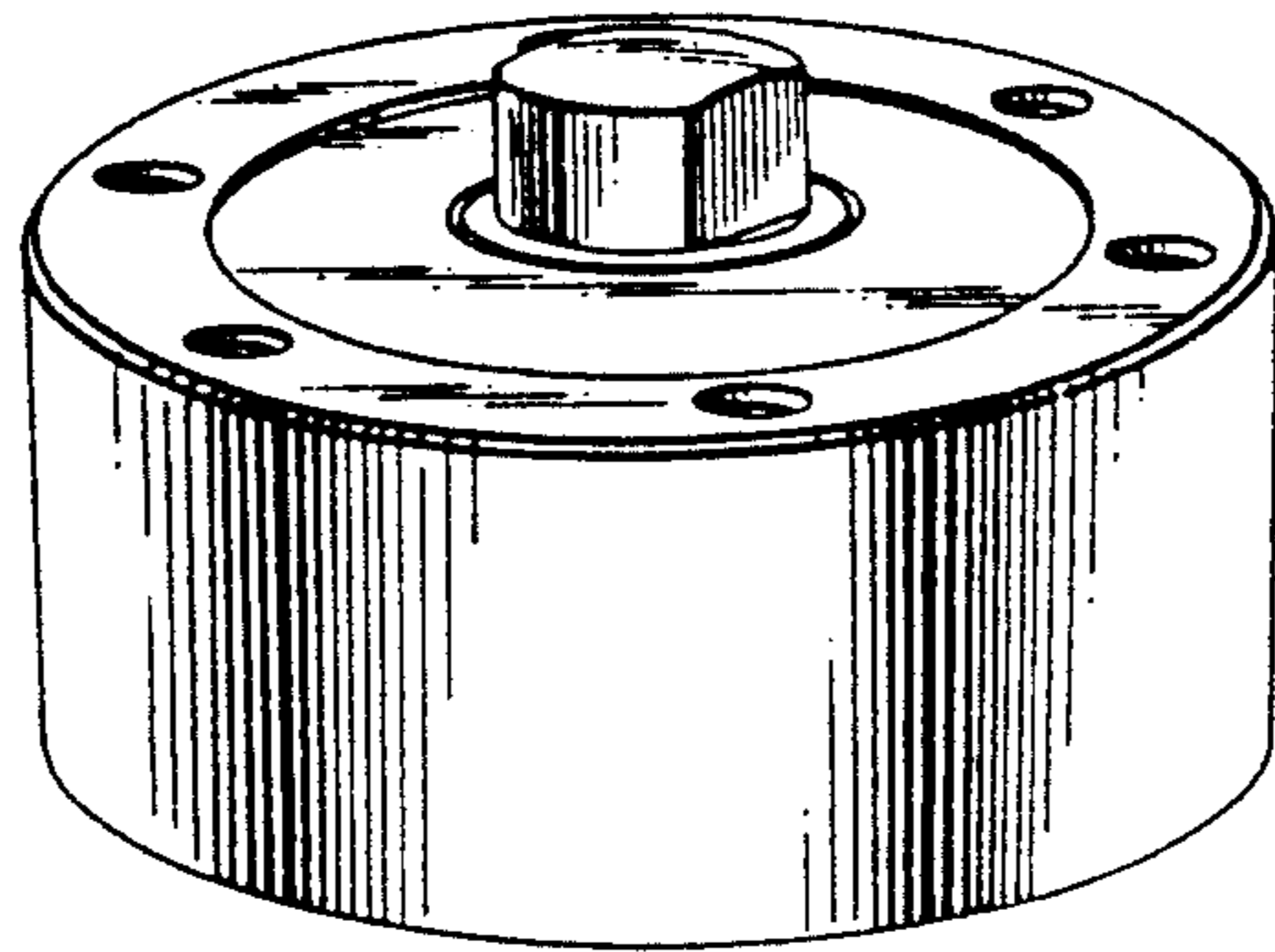

FIG. 2

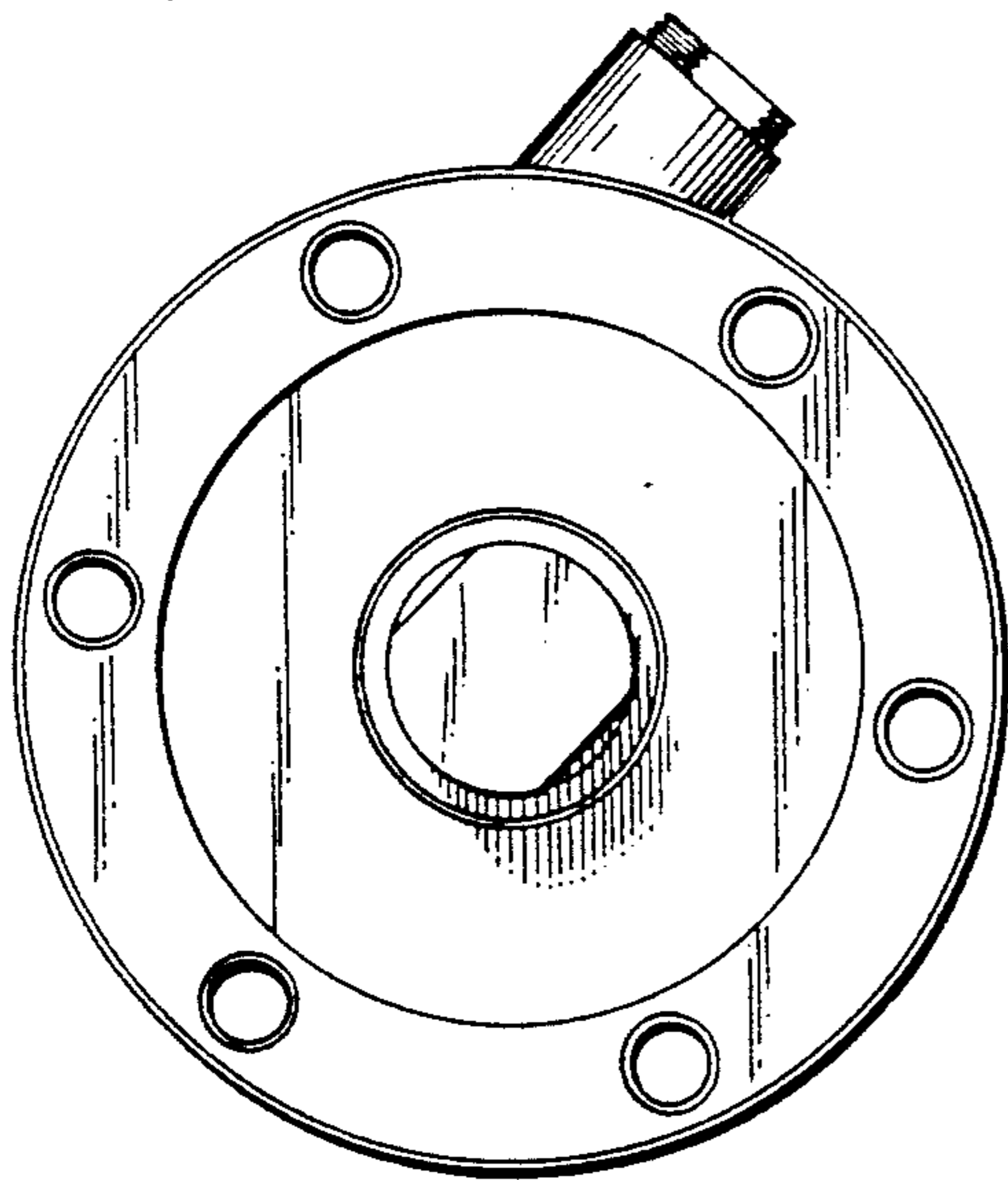

FIG. 3

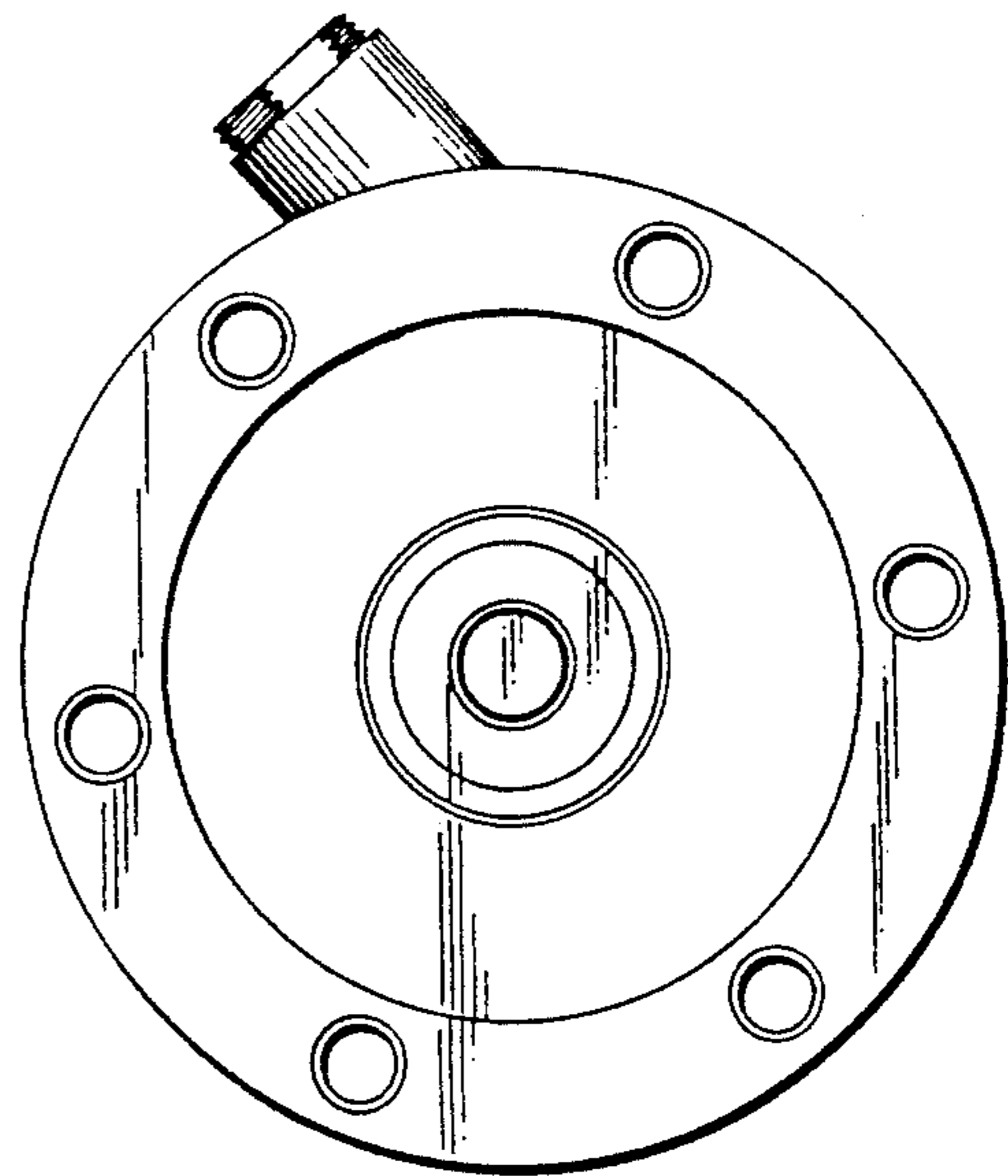

FIG. 4

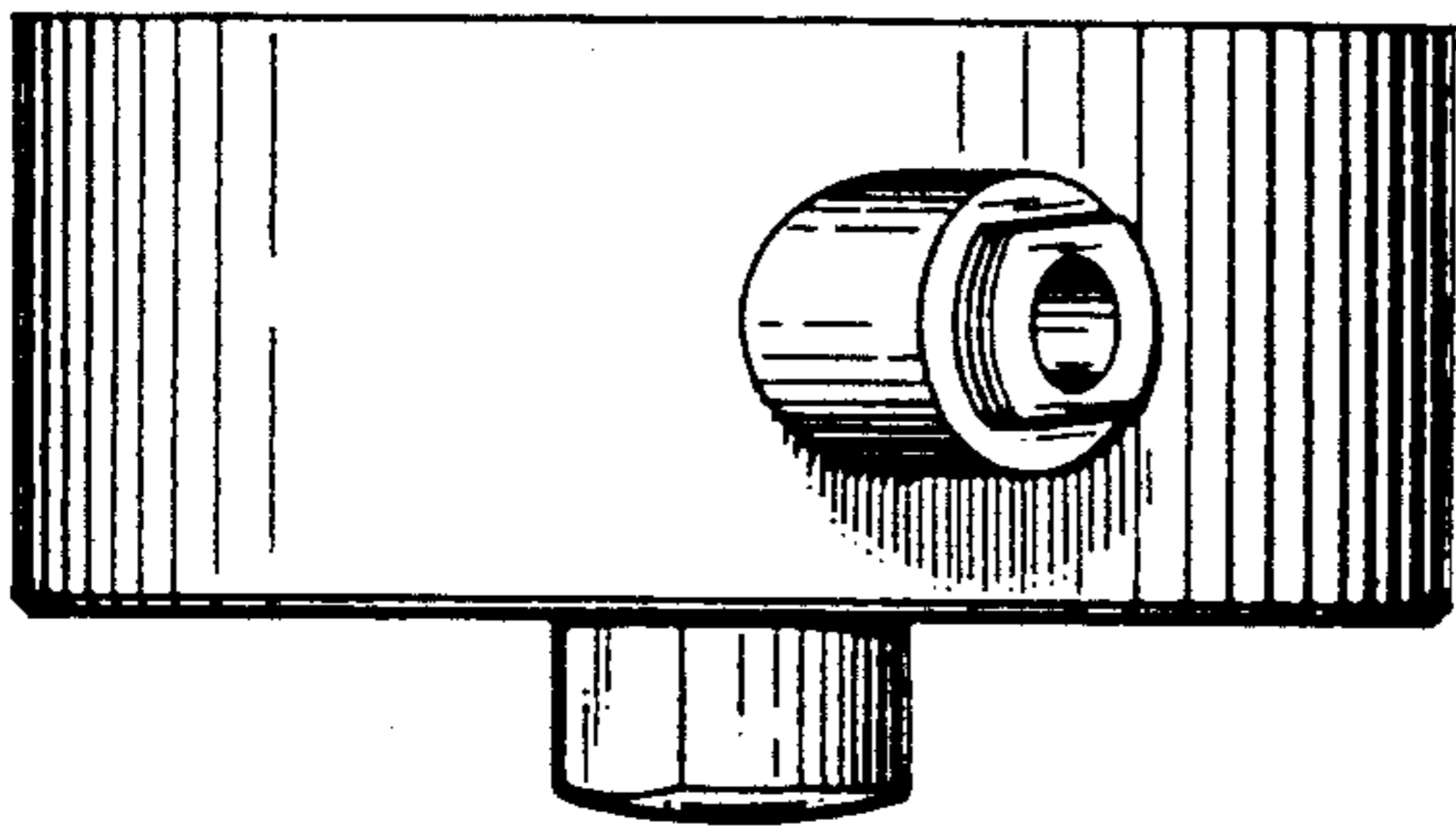

FIG. 5

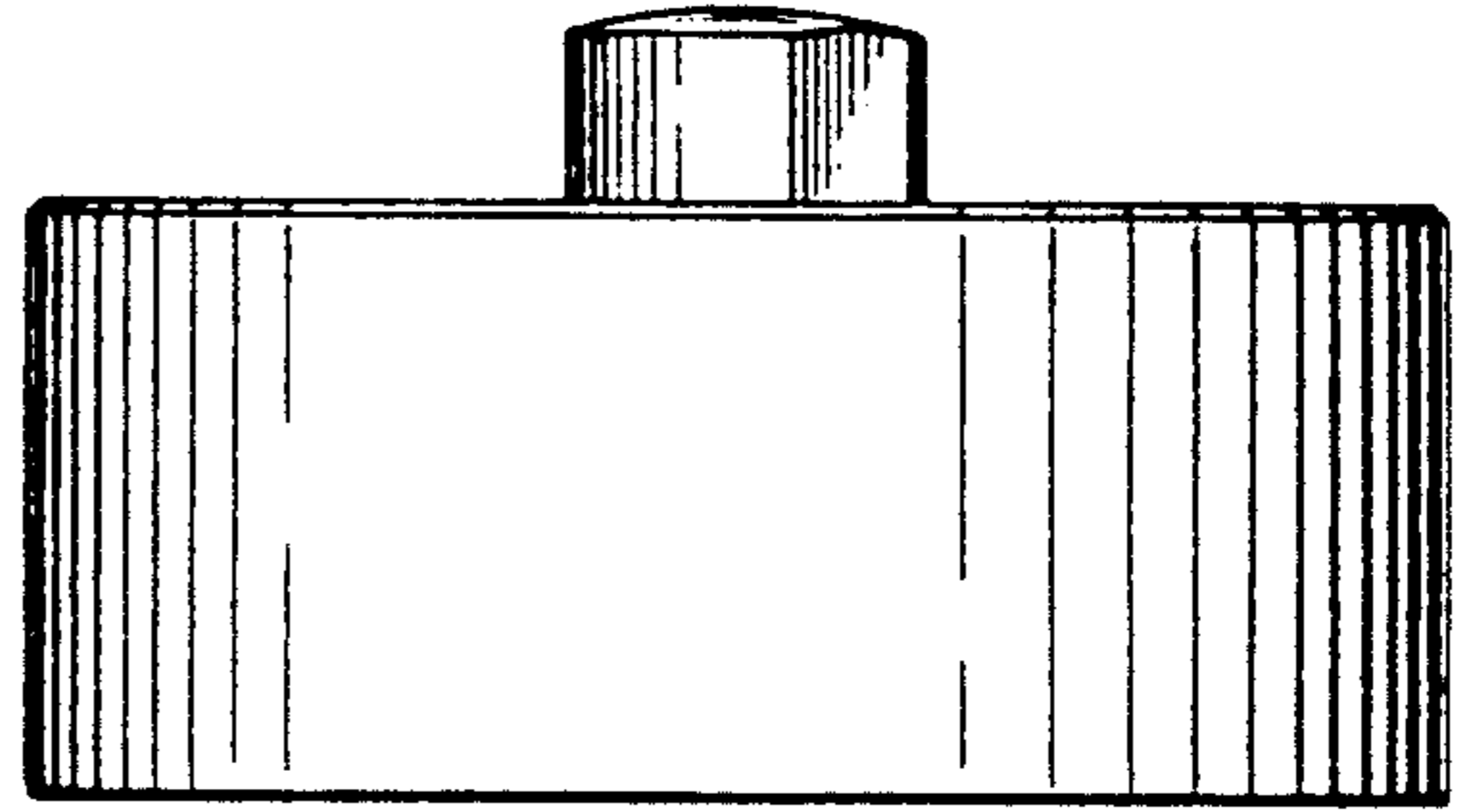

FIG. 6

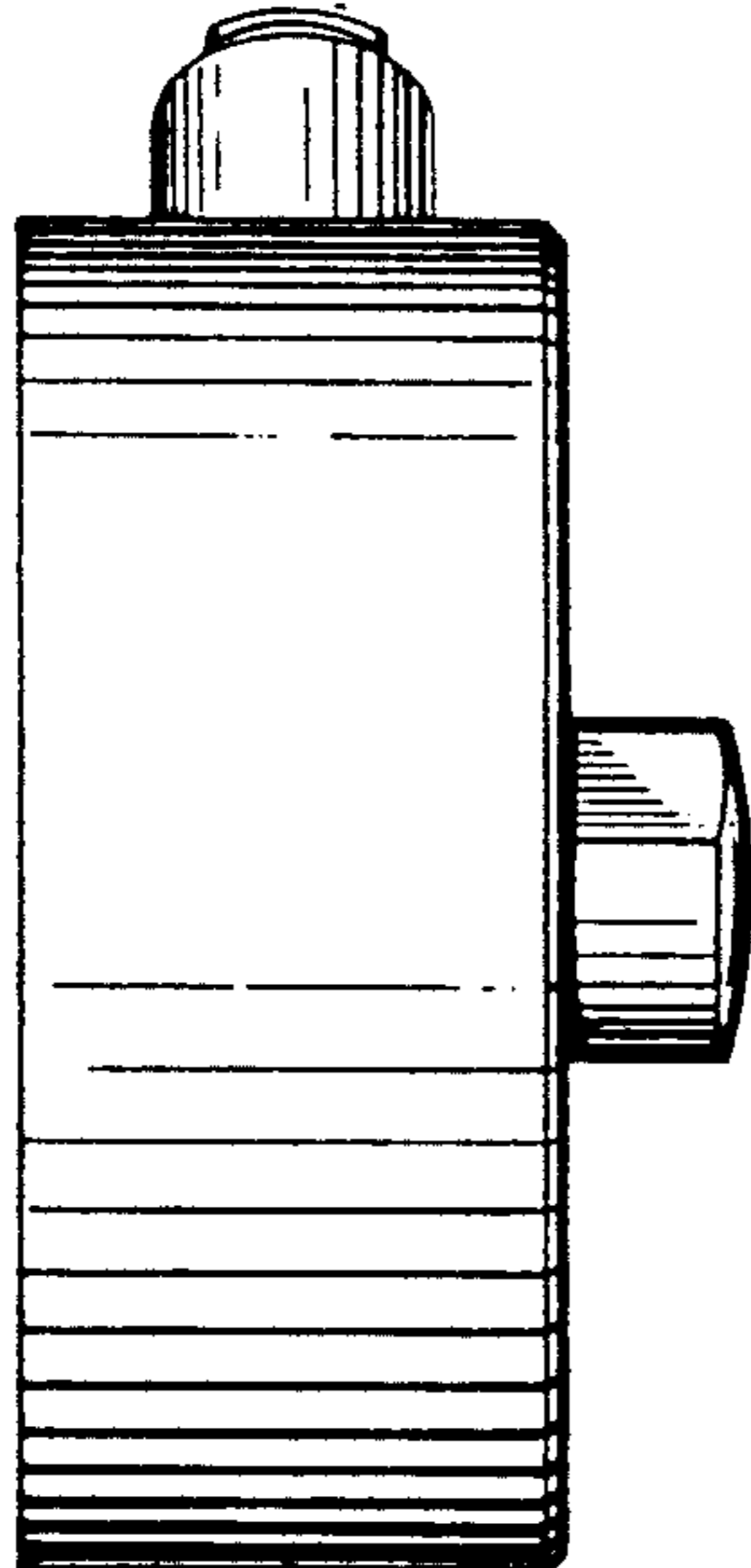

FIG. 7

