



US00D349032S

United States Patent [19] Gilbert

[11] Patent Number: Des. 349,032

[45] Date of Patent: ** Jul. 26, 1994

[54] VEHICLE ACCELERATOR PEDAL
DISABLING DEVICE

3,889,499 6/1975 Cramer 70/202

[76] Inventor: Melvin Gilbert, 9710 S. Genoa,
Chicago, Ill. 60643

[**] Term: 14 Years

[21] Appl. No.: 4,196

[22] Filed: Jan. 29, 1993

[52] U.S. Cl. D8/343; D8/346;
D8/334

[58] Field of Search D8/333-334,
D8/343, 346; 70/237, 255, 258, 14, 20, 35

[56] **References Cited**

U.S. PATENT DOCUMENTS

D. 212,170	9/1968	Owen et al.	D8/334
D. 269,519	7/1988	Newman et al.	D8/334
3,613,410	10/1971	Shaw	70/202
3,631,694	1/1972	Teroux	70/202

OTHER PUBLICATIONS

American Lock Company brochure, padlock.

Primary Examiner—Brian N. Vinson
Attorney, Agent, or Firm—Terry M. Gernstein

[57] **CLAIM**

The ornamental design for a vehicle accelerator pedal disabling device, as shown and described.

DESCRIPTION

FIG. 1 is a front, top and side perspective view of the vehicle accelerator pedal disabling device showing my new design;

FIG. 2 is a front elevational view thereof, the rear being a mirror image of the front shown in FIG. 2;

FIG. 3 is a side elevational view thereof, the side opposite being a mirror image of the side shown in FIG. 3;

FIG. 4 is a top plan view thereof; and,

FIG. 5 is a bottom plan view thereof.

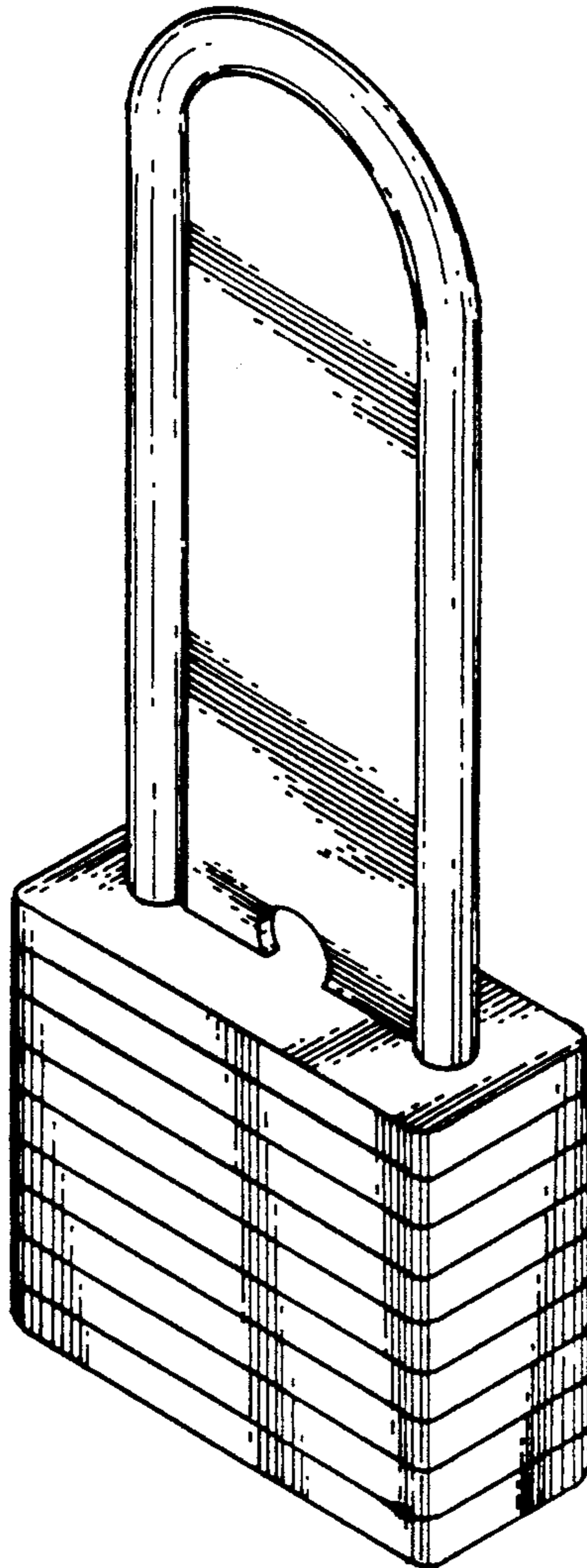

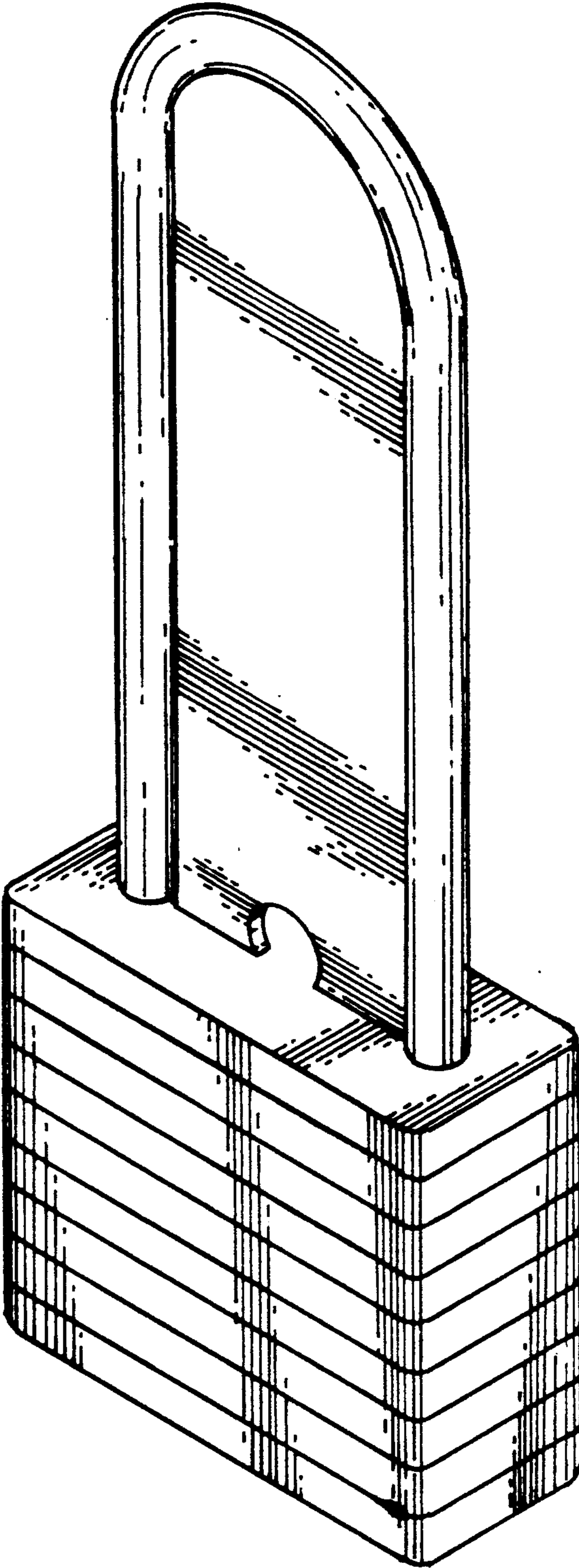

FIG. 1

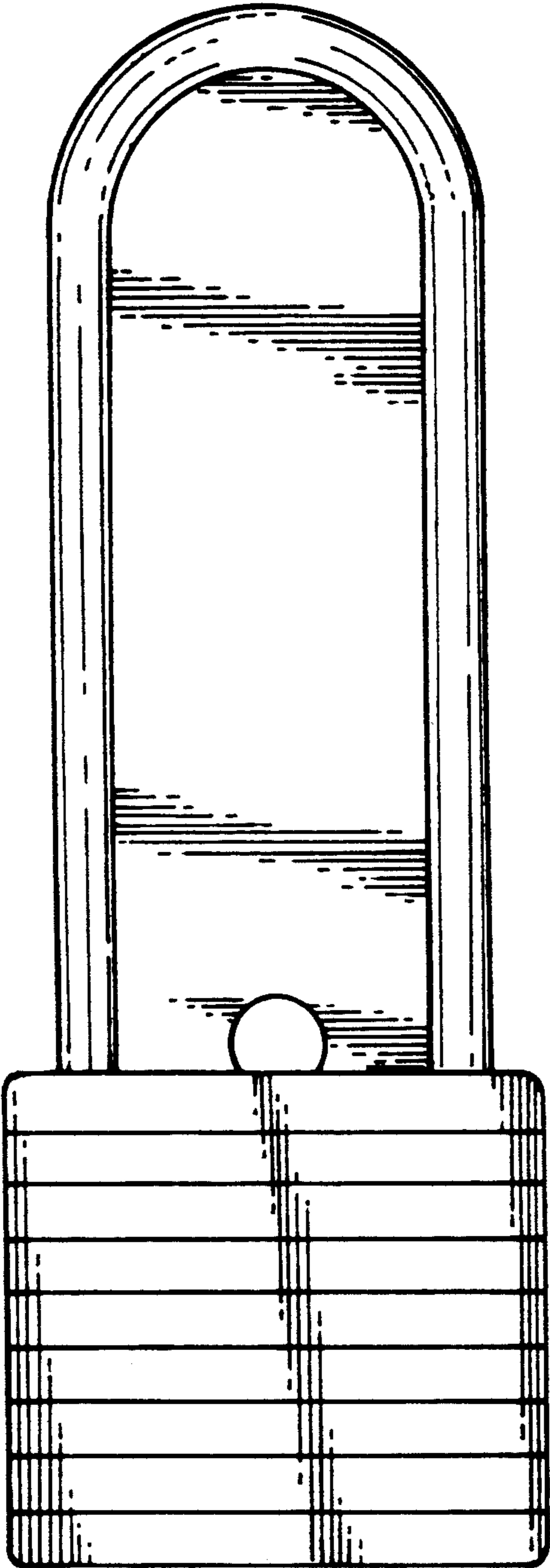

FIG. 2

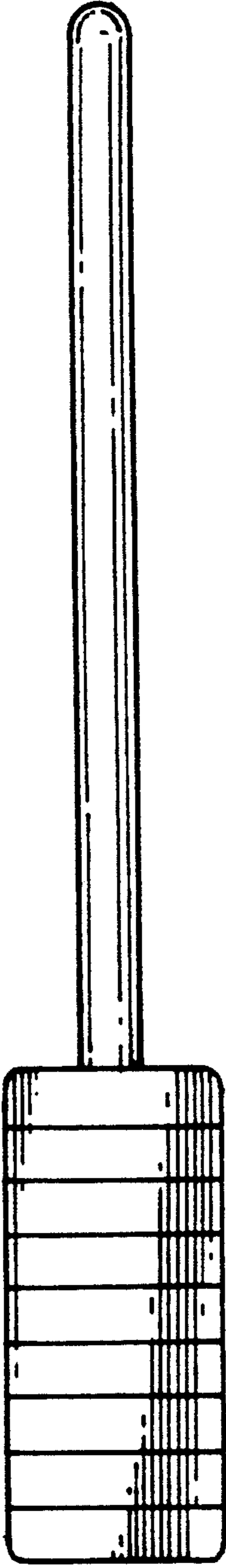

FIG. 3

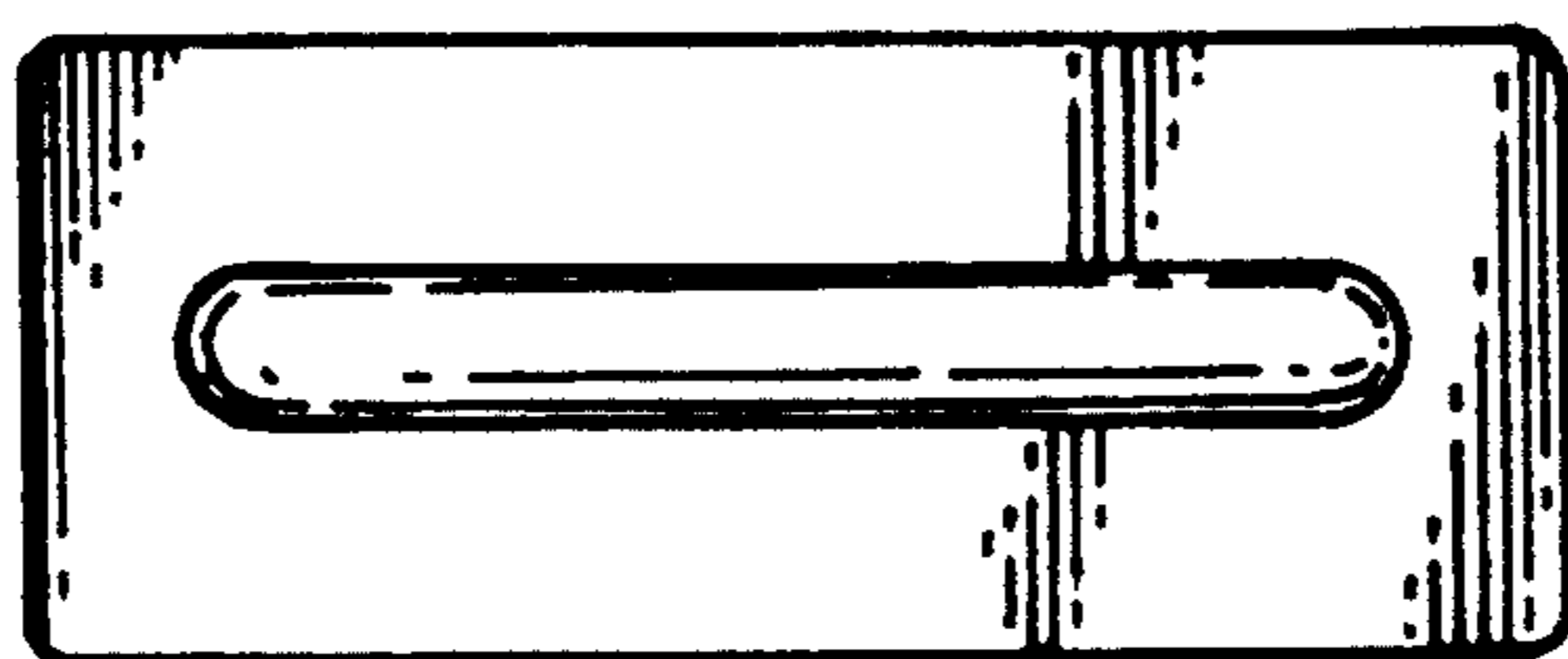

FIG. 4

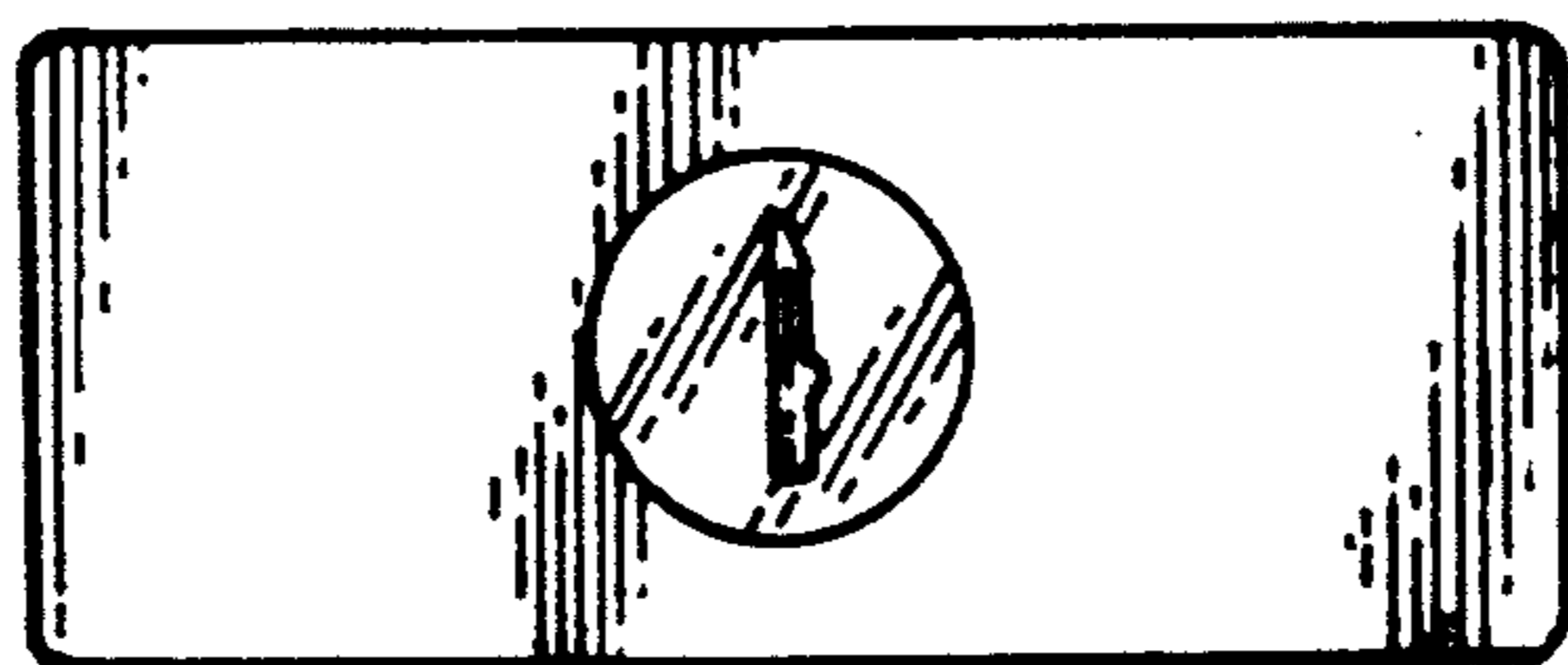

FIG. 5