



US00D348642S

United States Patent [19]

Wallace et al.

[11] Patent Number: **Des. 348,642**

[45] Date of Patent: *** Jul. 12, 1994**

[54] **ELONGATED TRAILER COUPLER HOUSING**

3,773,358	11/1973	Butler	280/513
4,993,759	2/1991	Putnam	280/511
5,080,386	1/1992	Lazar	280/511

[75] Inventors: **Jeffrey D. Wallace**, Des Moines;
Herbert O. Dixon, Jr., West Des Moines, both of Iowa

Primary Examiner—Wallace R. Burke
Assistant Examiner—Melody Brown
Attorney, Agent, or Firm—Brian J. Laurenzo; Kent A. Herink; Brett J. Trout

[73] Assignee: **Dico, Inc.**, Des Moines, Iowa

[*] Notice: The portion of the term of this patent subsequent to Apr. 12, 2008 has been disclaimed.

[57] **CLAIM**

The ornamental design for an elongated trailer coupler housing, as shown and described.

[**] Term: **14 Years**

DESCRIPTION

[21] Appl. No.: **801,841**

FIG. 1 is a top and side perspective view of an elongated trailer coupler housing showing our new design, it being understood that the broken lines are for illustrative purposes only and form no part of the claimed design.

[22] Filed: **Dec. 3, 1991**

[52] U.S. Cl. **D12/162**

FIG. 2 is a top plan view thereof;

[58] Field of Search 280/511-513;

D12/162

FIG. 3 is a left side elevational view thereof;

[56] **References Cited**

U.S. PATENT DOCUMENTS

D. 320,777 10/1991 Goettker D12/162

FIG. 4 is a front elevational view thereof;

FIG. 5 is a bottom plan view thereof;

FIG. 6 is a right side elevational view thereof; and,

FIG. 7 is a rear elevational view thereof.

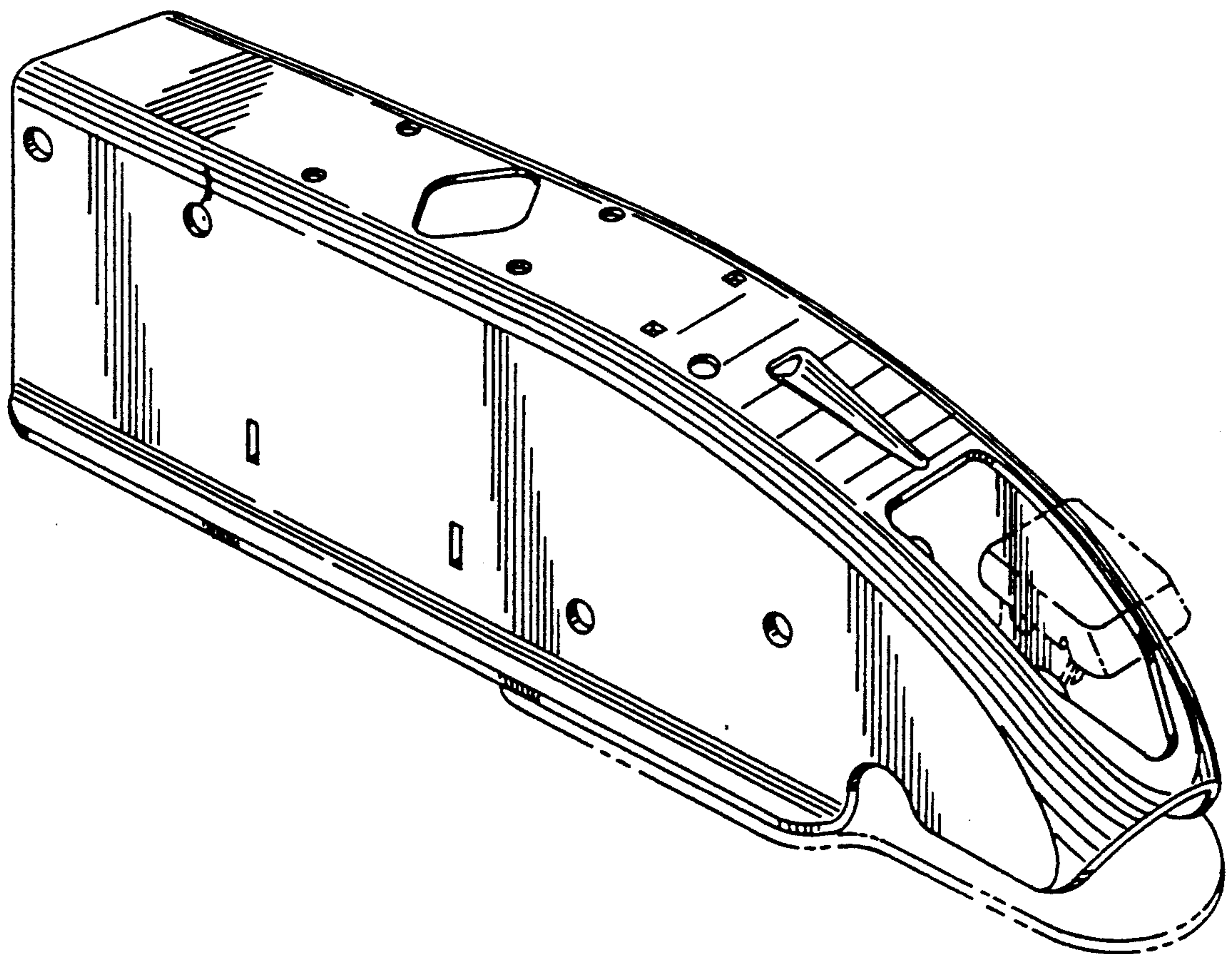

FIG. 1

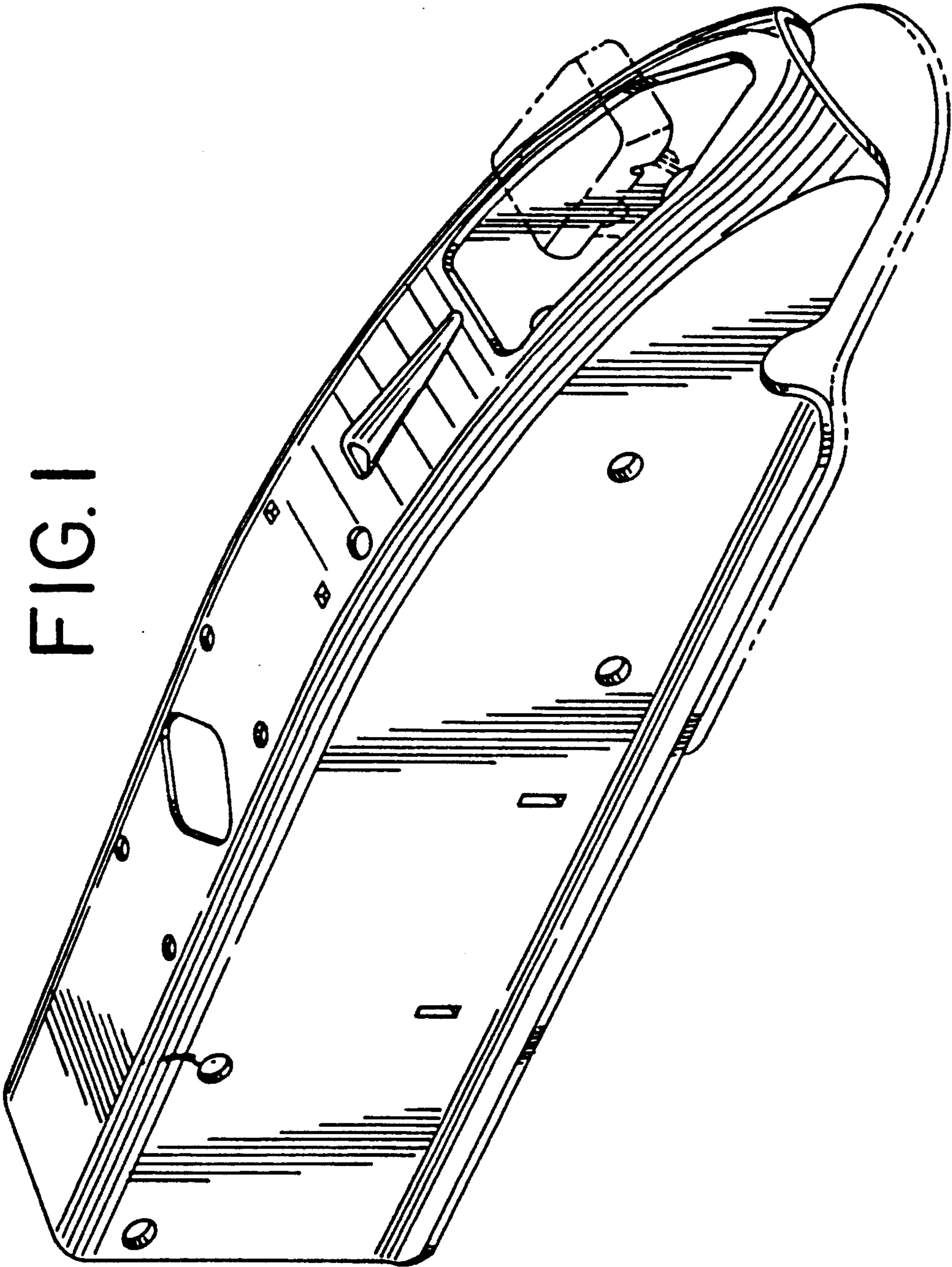

FIG.2

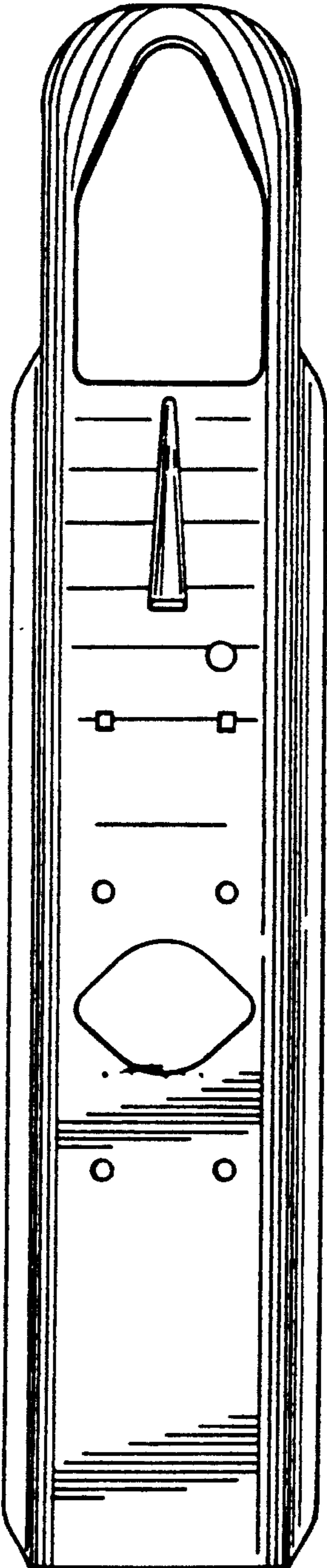

FIG.3

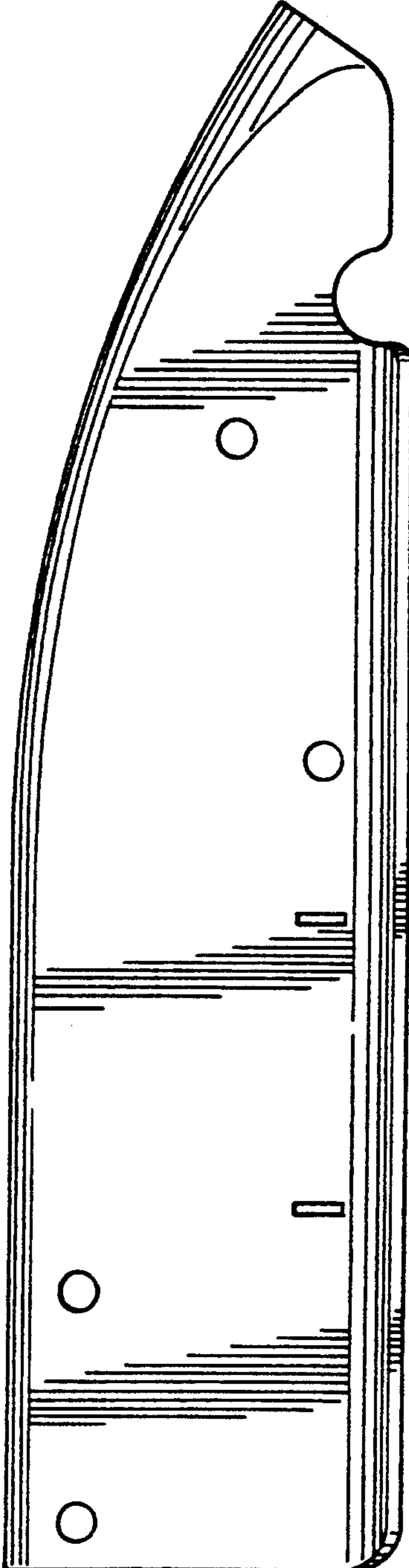

FIG.4

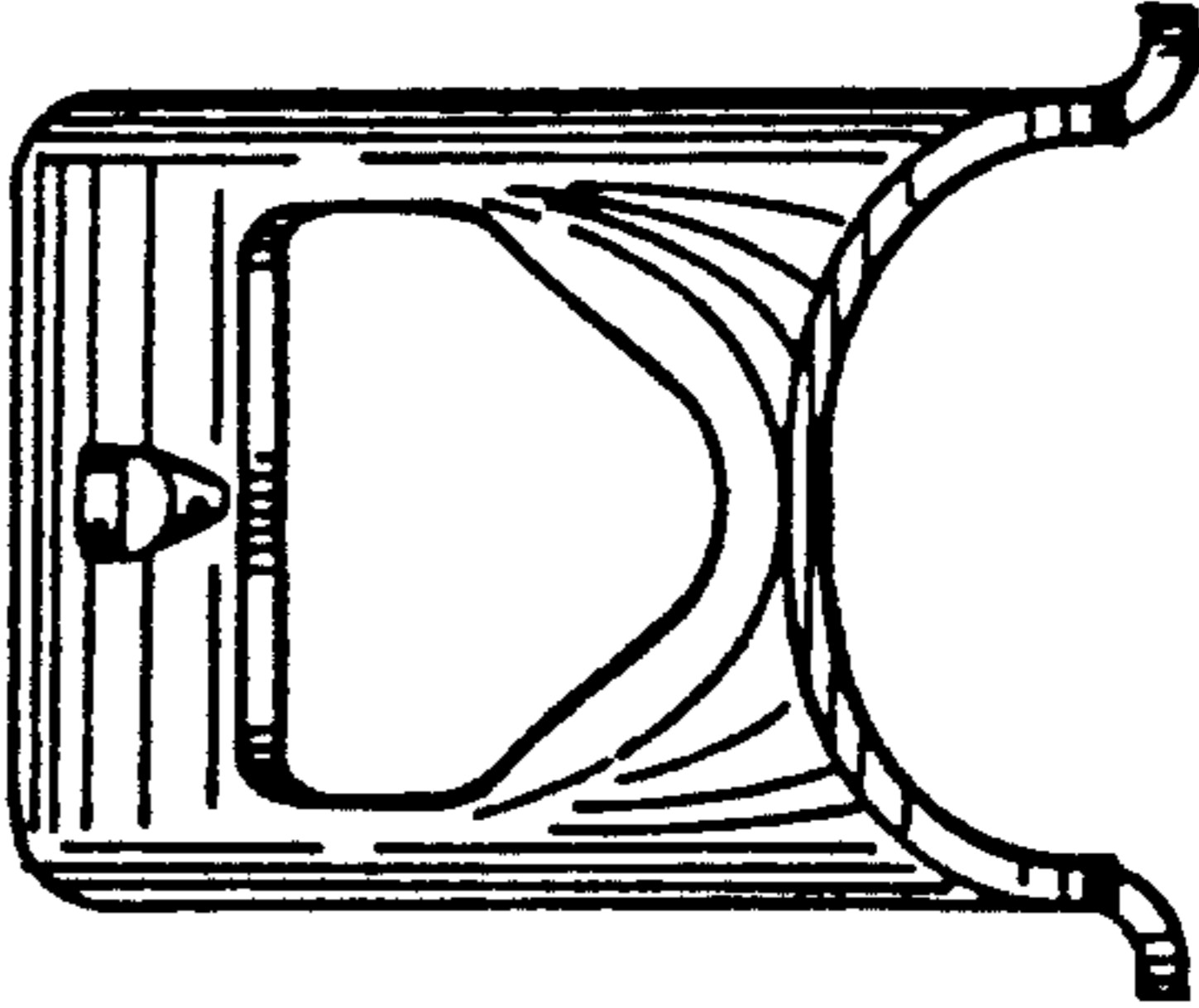

FIG. 5

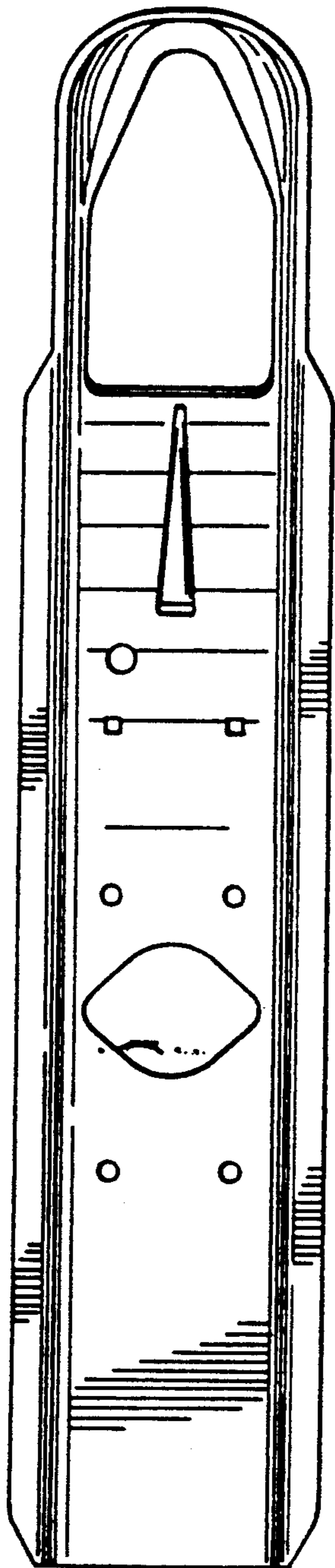

FIG. 6

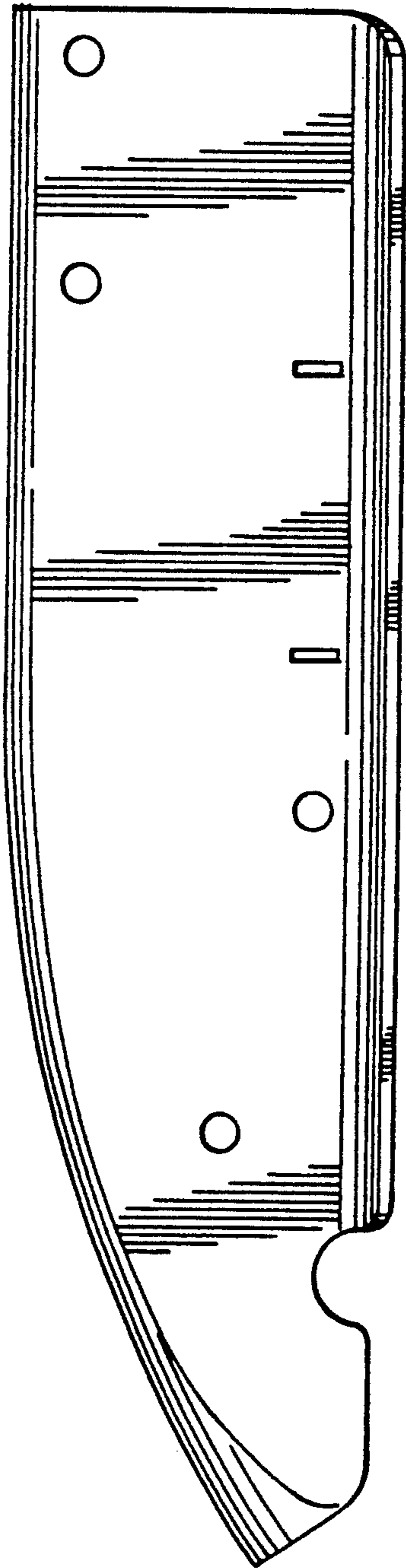

FIG. 7

