



US00D348553S

United States Patent [19]

[11] Patent Number: **Des. 348,553**

Martin, Jr.

[45] Date of Patent: **** Jul. 5, 1994**

[54] **VEHICLE CAB**

4,515,234 5/1985 Loy et al. 180/89.12
4,650,242 3/1987 Obe et al. 180/89.12

[75] Inventor: **Robert P. Martin, Jr.,** Cleveland, Ohio

Primary Examiner—Kay H. Chin
Attorney, Agent, or Firm—Pearne, Gordon, McCoy & Granger

[73] Assignee: **Martin Sheet Metal, Inc.,** Cleveland, Ohio

[**] Term: **14 Years**

[57] CLAIM

The ornamental design for a vehicle cab, as shown and described.

[21] Appl. No.: **3,877**

DESCRIPTION

[22] Filed: **Jan. 21, 1993**

[52] U.S. Cl. **D34/37; D34/34**

[58] Field of Search 180/89.12; 296/190;
D34/37, 28; D15/30

FIG. 1 is a perspective view showing the rear and one side of my new design for a vehicle cab it being understood that the broken lines are for illustrative purposes only;

FIG. 2 is a perspective view showing the front and opposite side thereof;

FIG. 3 is a front elevational view thereof;

FIG. 4 is a top plan view thereof;

FIG. 5 is a left side elevational view thereof;

FIG. 6 is a right side elevational view thereof; and,

FIG. 7 is a rear elevational view thereof.

[56] References Cited

U.S. PATENT DOCUMENTS

- | | | | | |
|------------|---------|---------------|-------|--------|
| D. 249,254 | 9/1978 | Martin, Sr. | | D34/37 |
| D. 274,276 | 6/1984 | Martin, Jr. | | D34/37 |
| D. 276,758 | 12/1984 | Krueck et al. | | D34/34 |
| D. 292,632 | 11/1987 | Lich | | D34/37 |

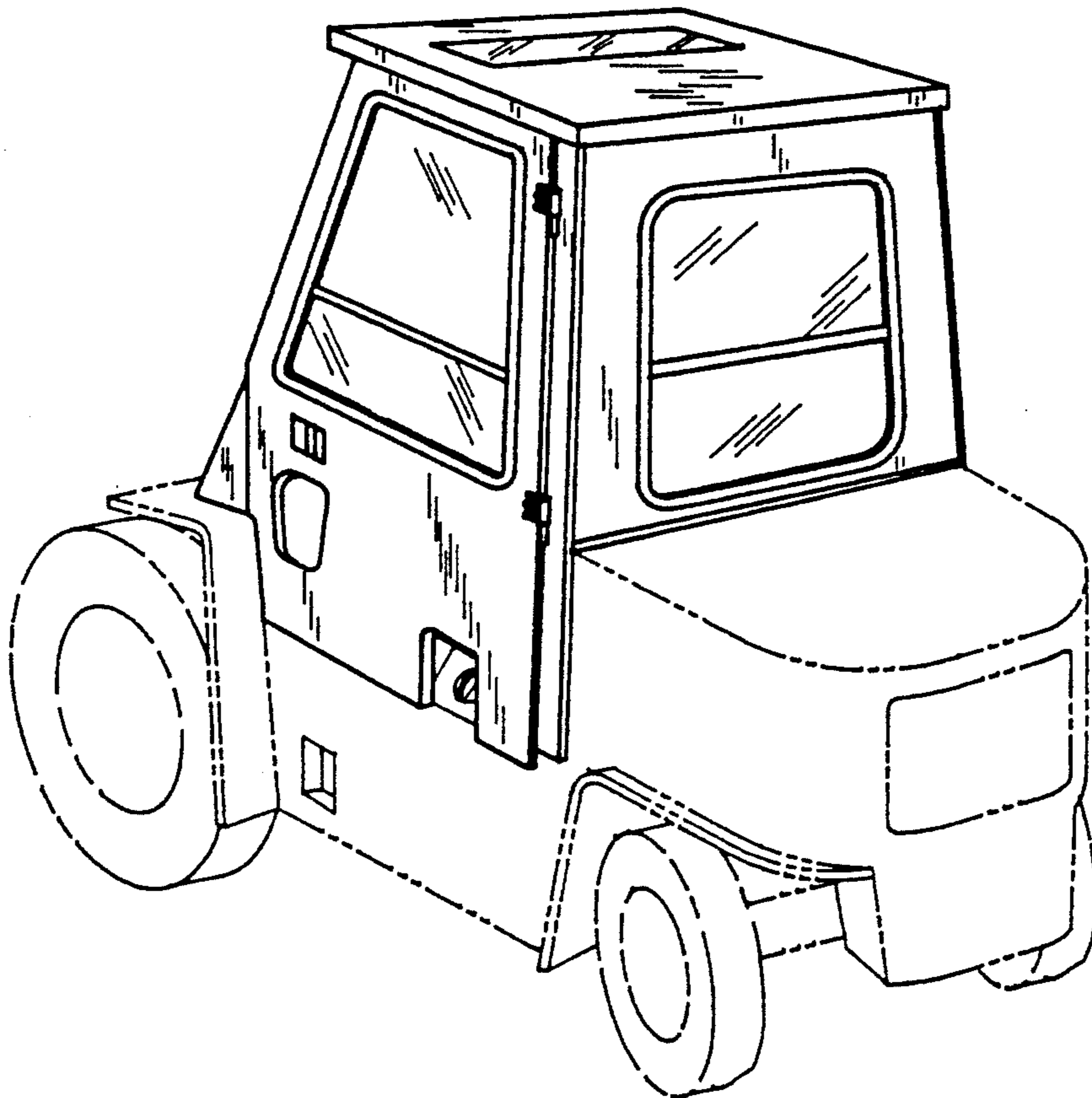

Fig. 1

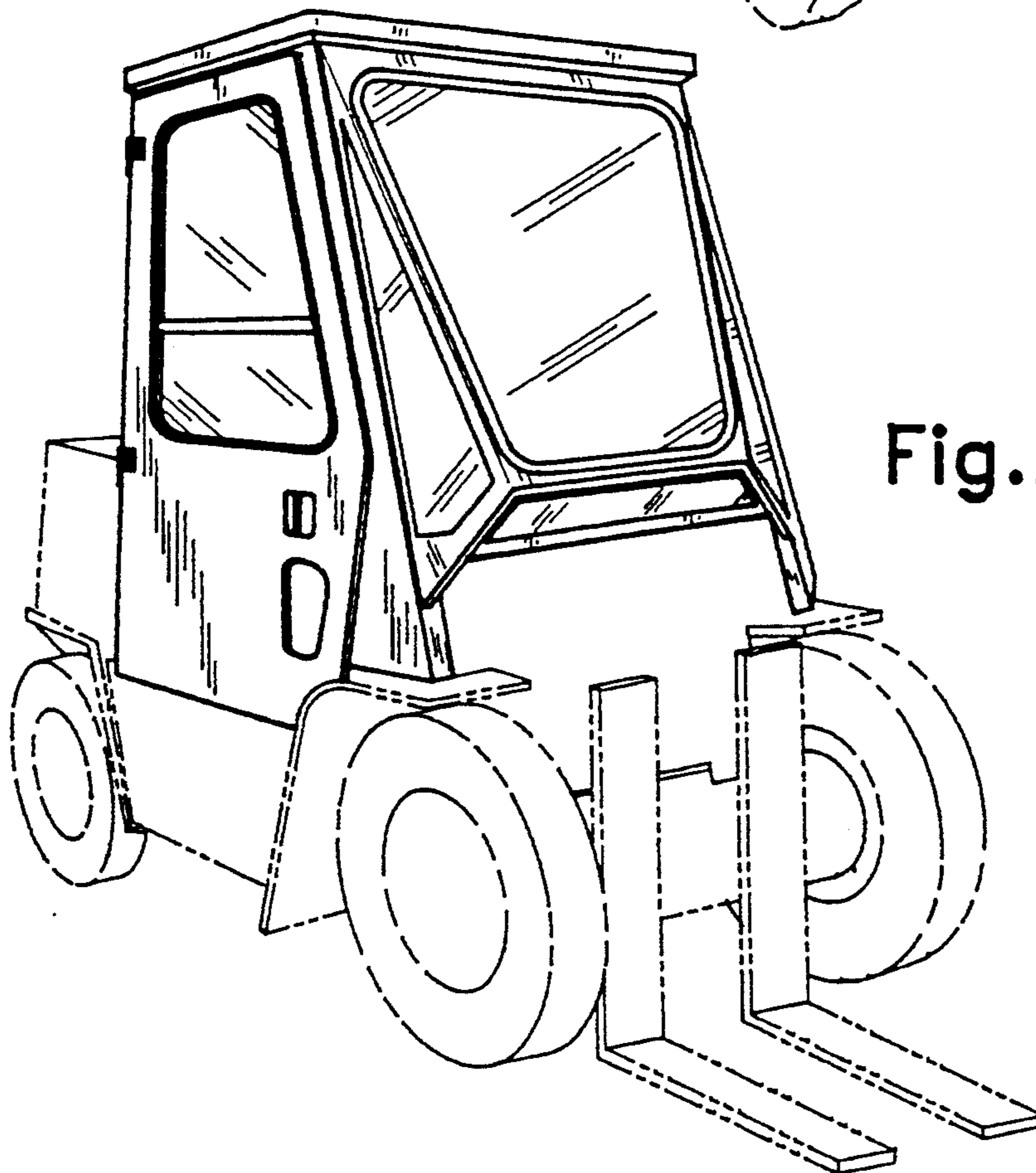
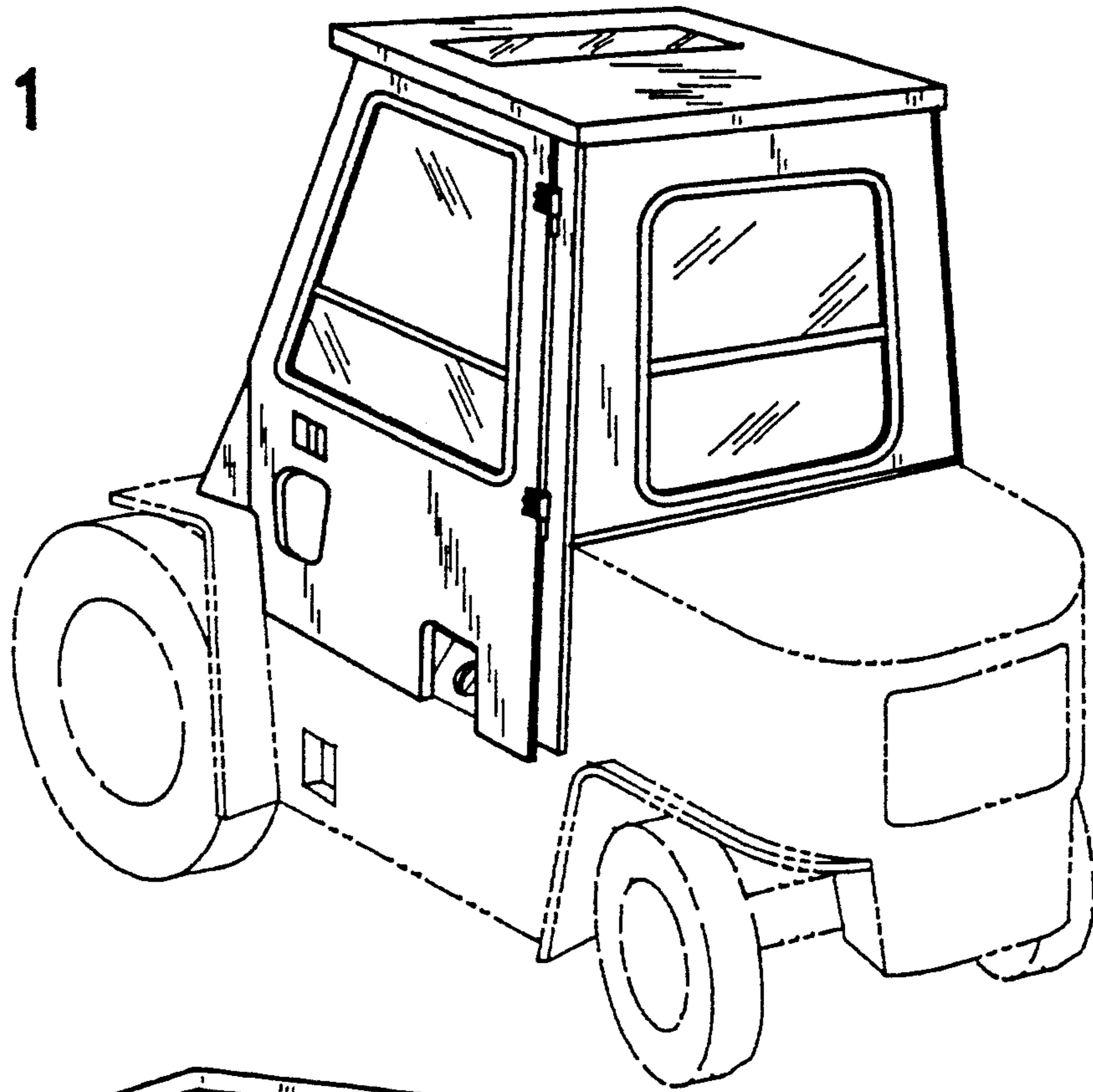

Fig. 2

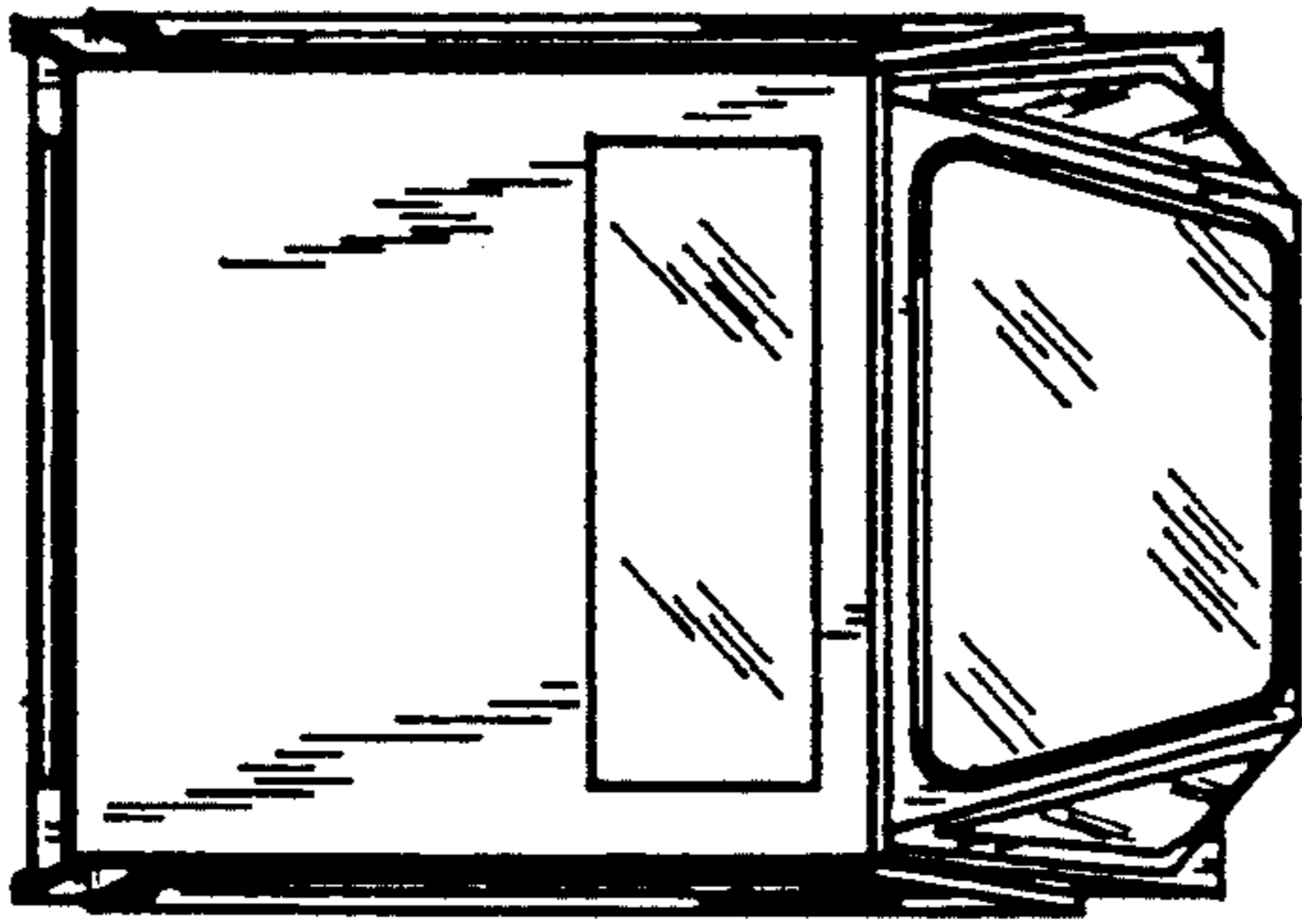

Fig. 4

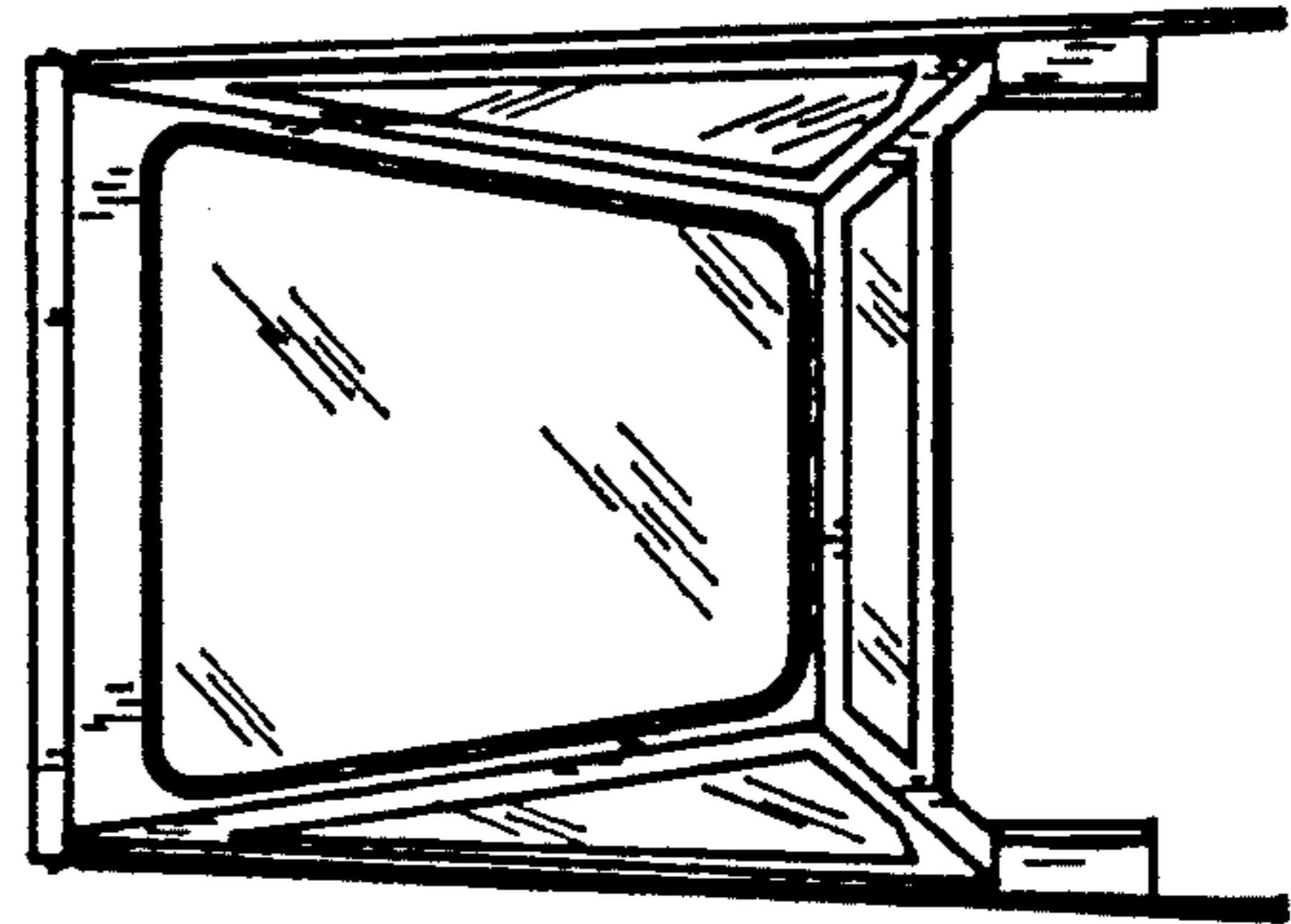

Fig. 3

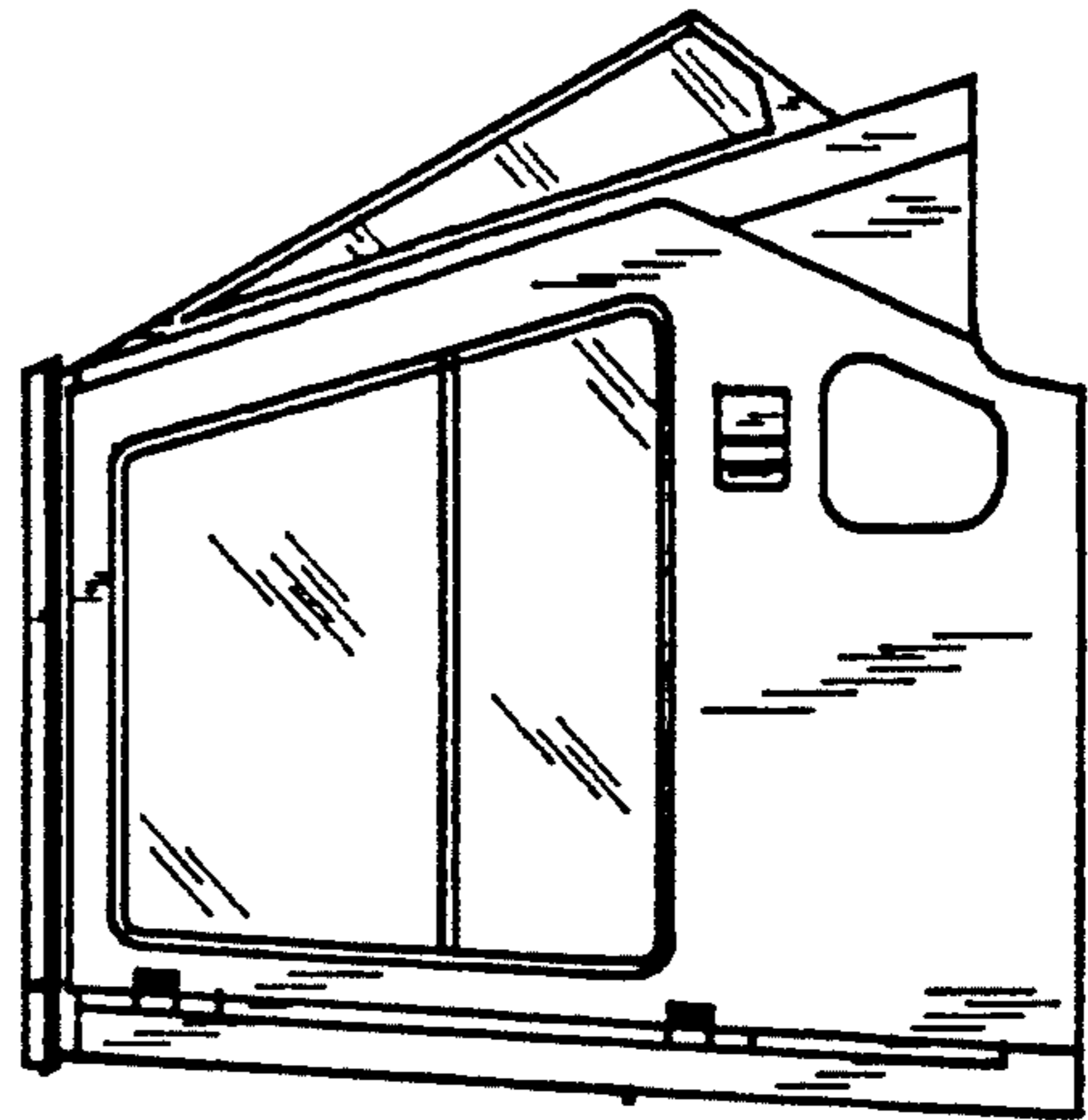

Fig. 6

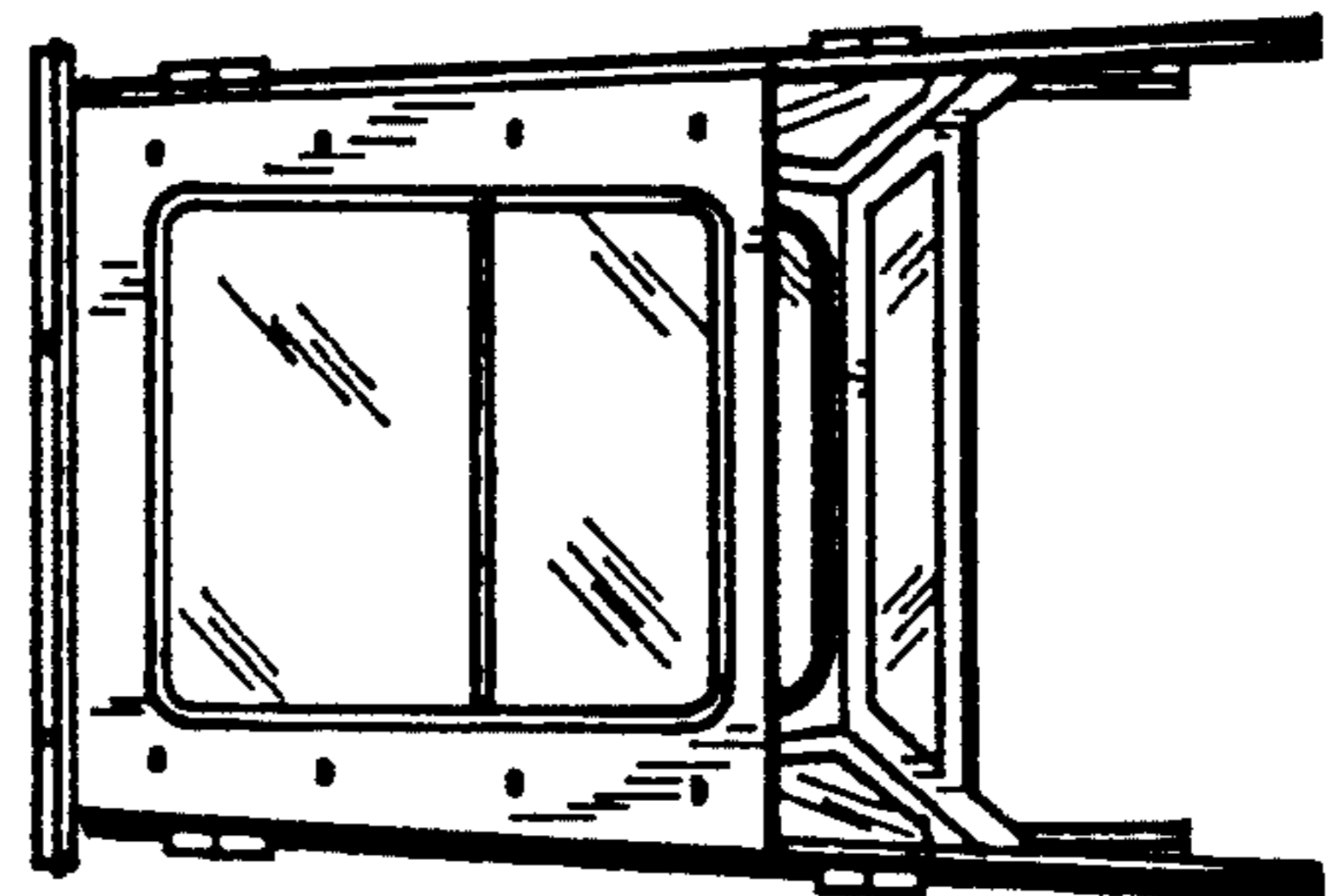

Fig. 7

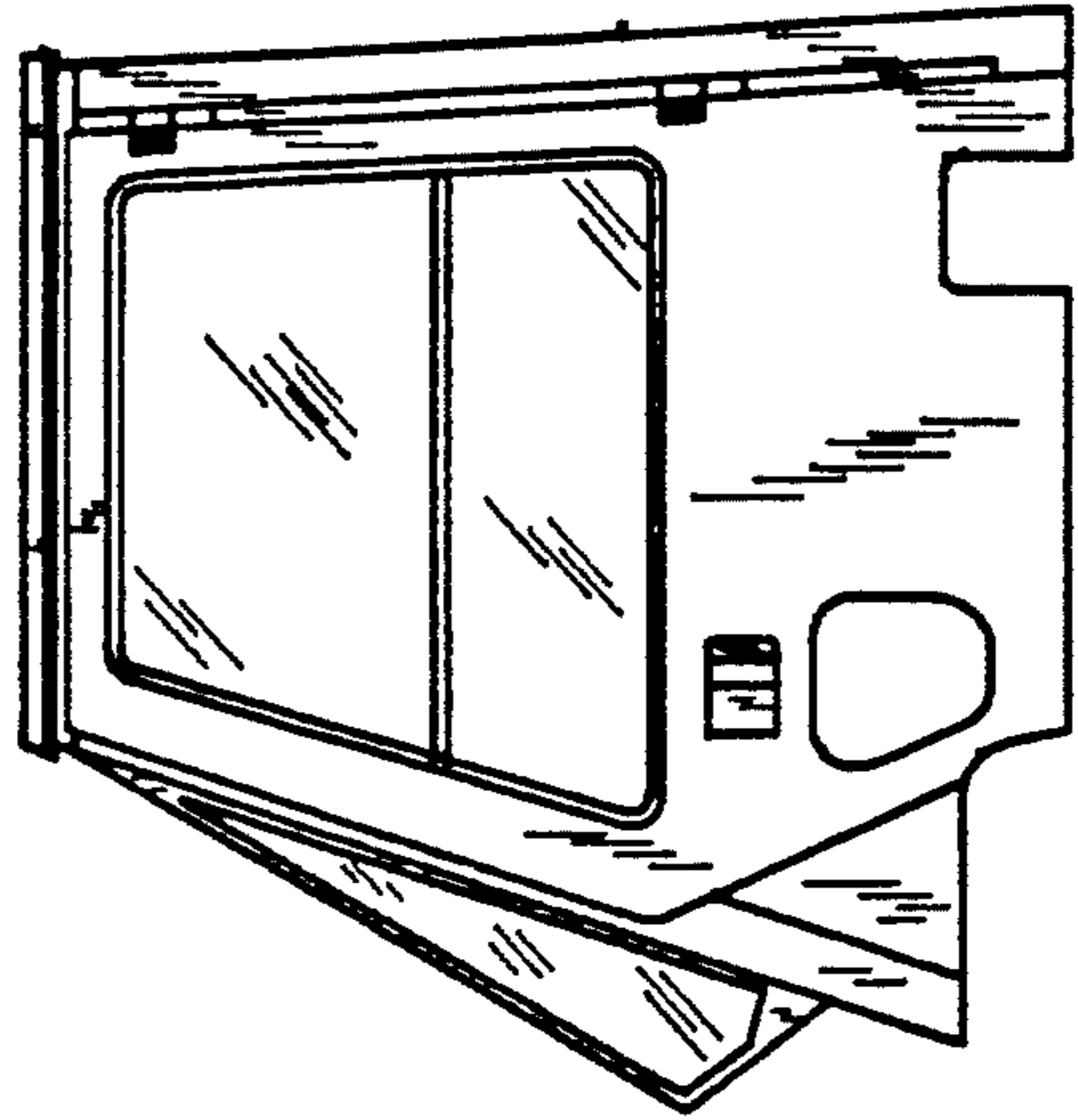

Fig. 5