



US00D348532S

United States Patent [19]

Belisle

[11] Patent Number: **Des. 348,532**

[45] Date of Patent: **** Jul. 5, 1994**

[54] **SUSPENDED LUMINAIRE**

[75] Inventor: **William W. Belisle, Newark, Ohio**

[73] Assignee: **Holophane Company, Inc., Newark, Ohio**

[*] Notice: **The portion of the term of this patent subsequent to Jan. 11, 2008 has been disclaimed.**

[**] Term: **14 Years**

[21] Appl. No.: **857,306**

[22] Filed: **Mar. 25, 1992**

[52] U.S. Cl. **D26/85**

[58] Field of Search **362/147, 404-408; D26/72, 80-92**

[56] **References Cited**

U.S. PATENT DOCUMENTS

D. 298,862 12/1988 Tharp et al. D26/88
4,449,168 5/1984 Ewing 362/147 X

OTHER PUBLICATIONS

Crouse-Hinds Lighting Design & Selection Guide, 1987 p. 5, Indoor Industrial Fixture 8'-20' mounting.

Primary Examiner—Susan J. Lucas
Attorney, Agent, or Firm—Brooks & Kushman

[57] **CLAIM**

The ornamental design for a suspended luminaire, as shown.

DESCRIPTION

FIG. 1 is a perspective view of my new design;
FIG. 2 is a front elevational view;
FIG. 3 is a right side elevational view;
FIG. 4 is a top plan view;
FIG. 5 is a bottom plan view; and,
FIG. 6 is a rear elevational view.

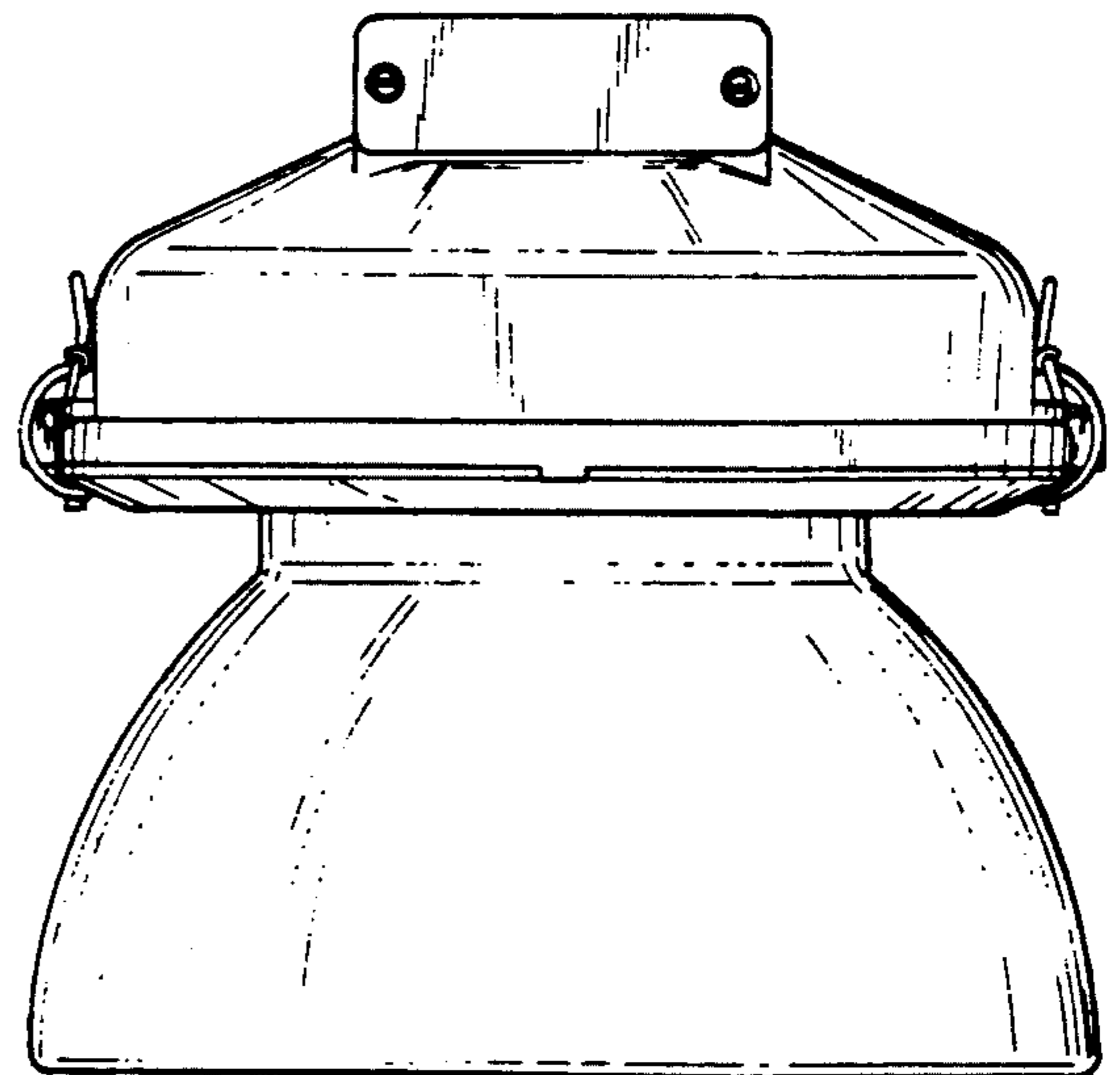
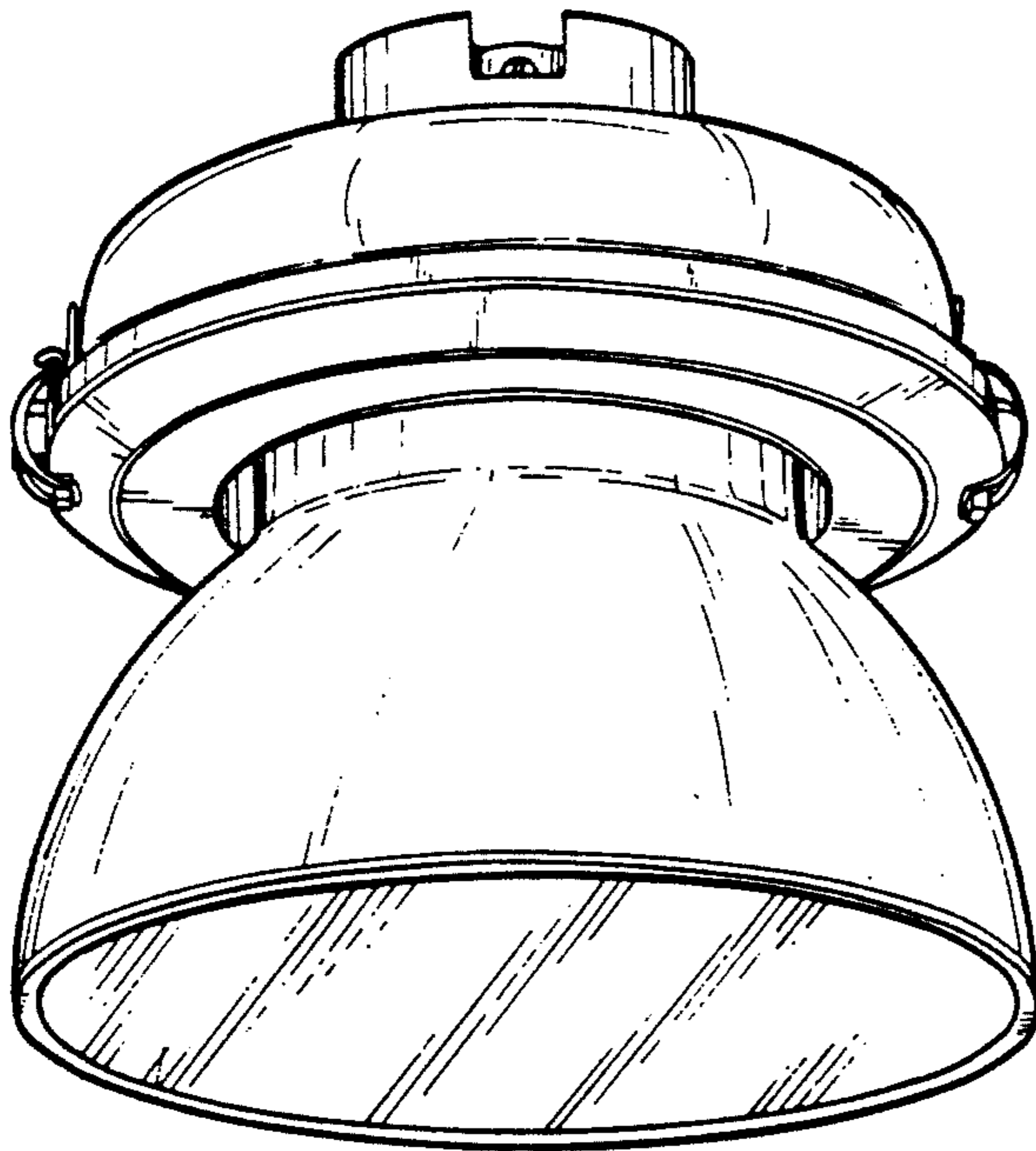

fig-1

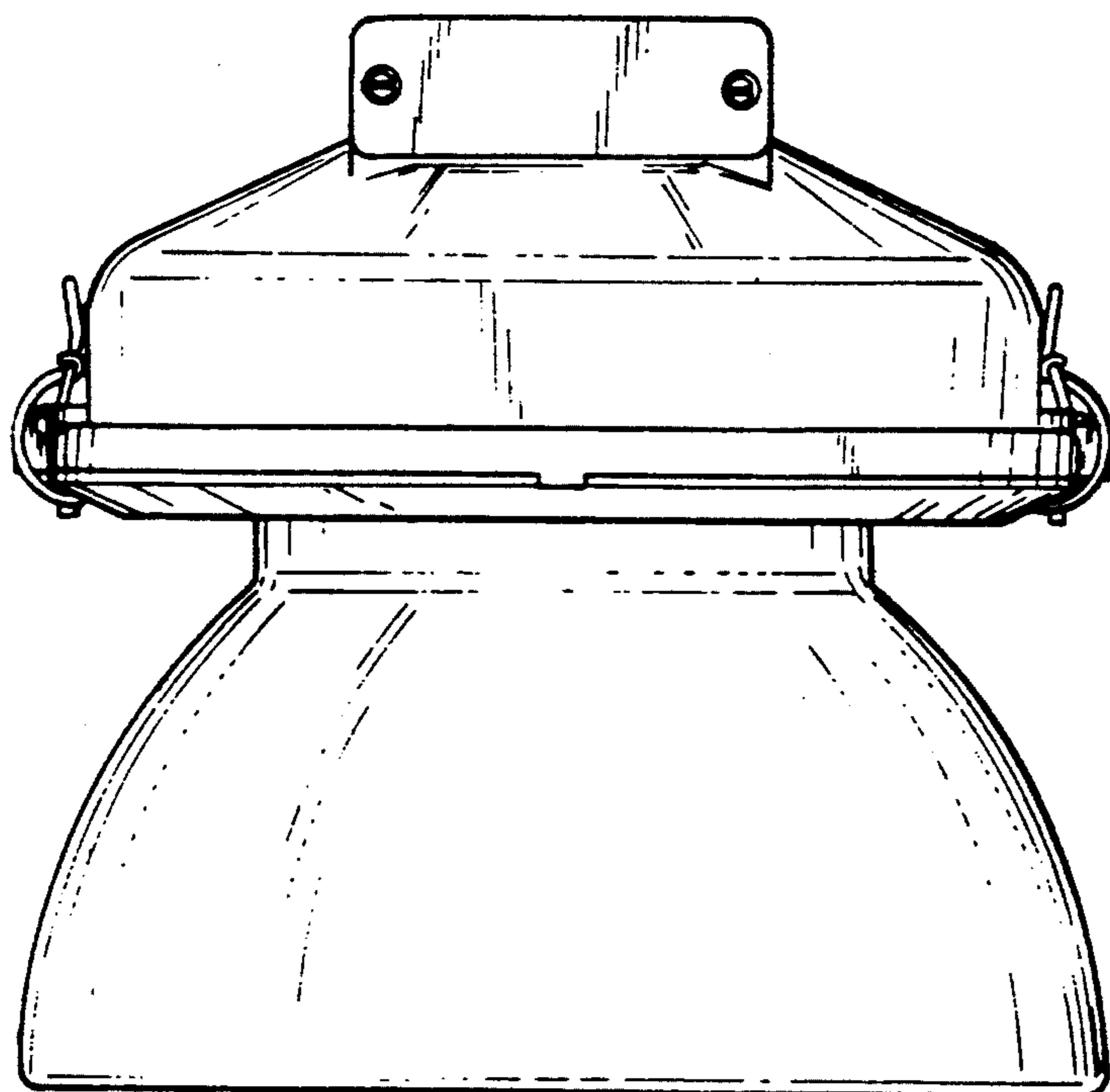
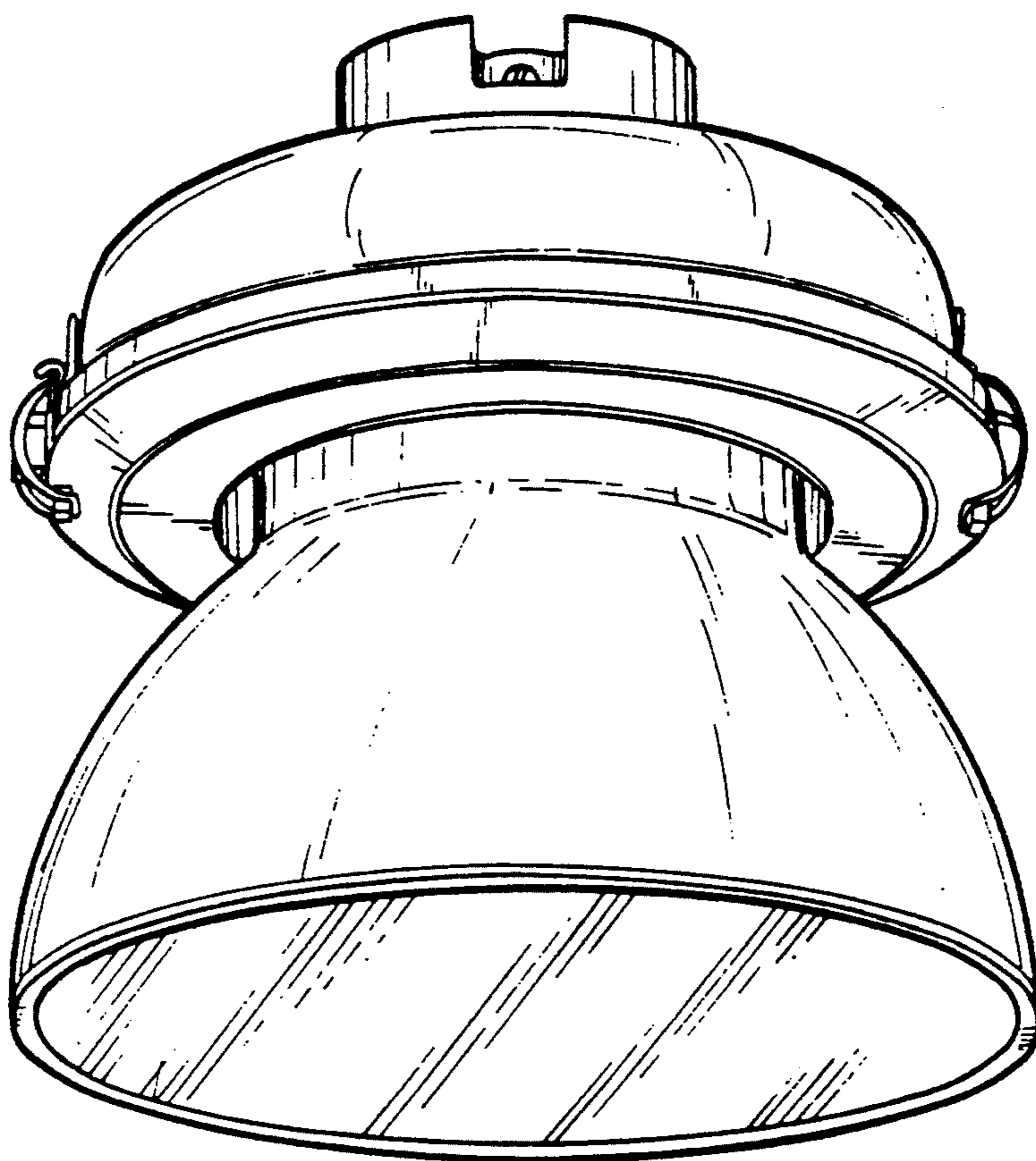

fig-2

fig-3

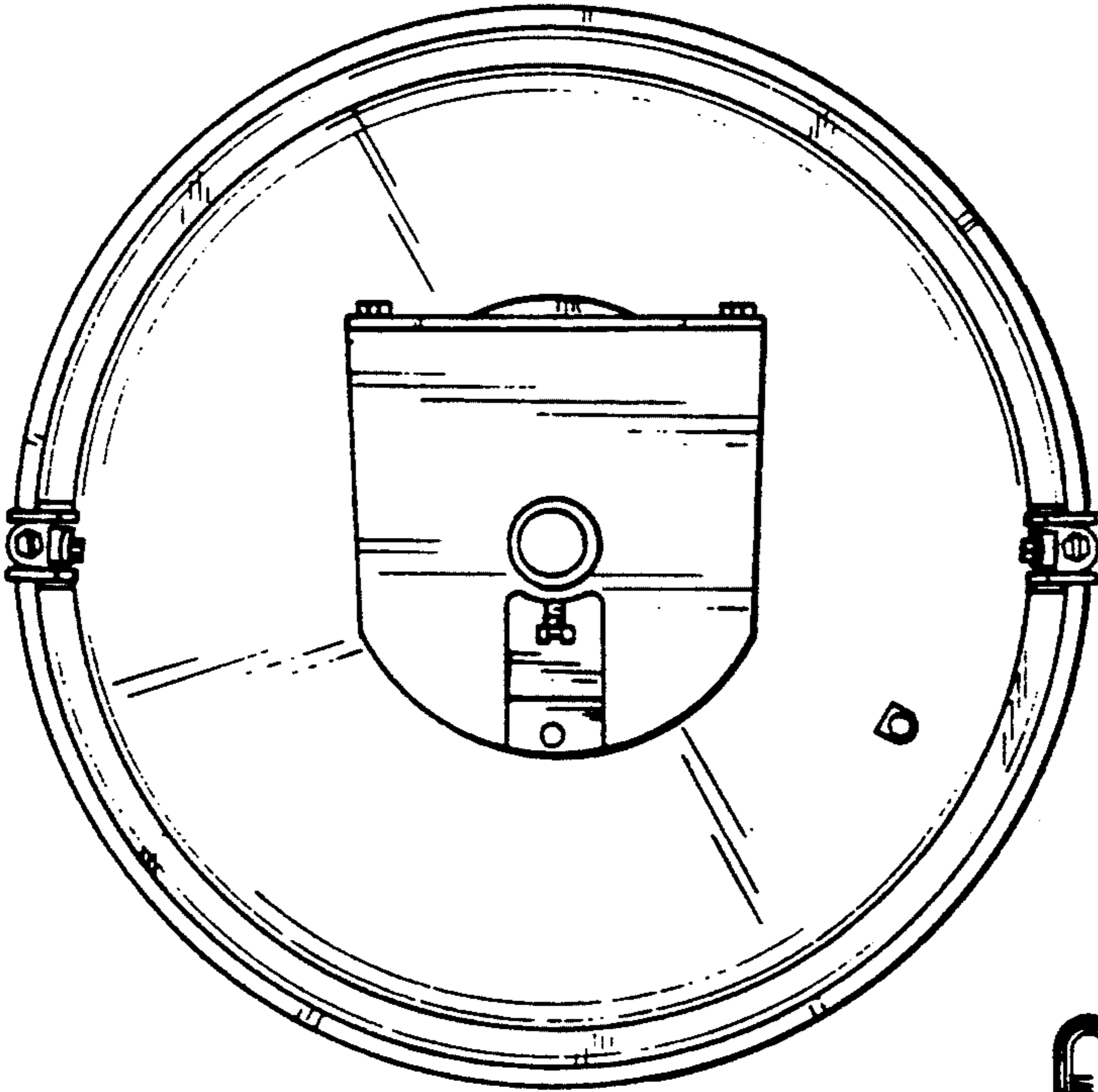
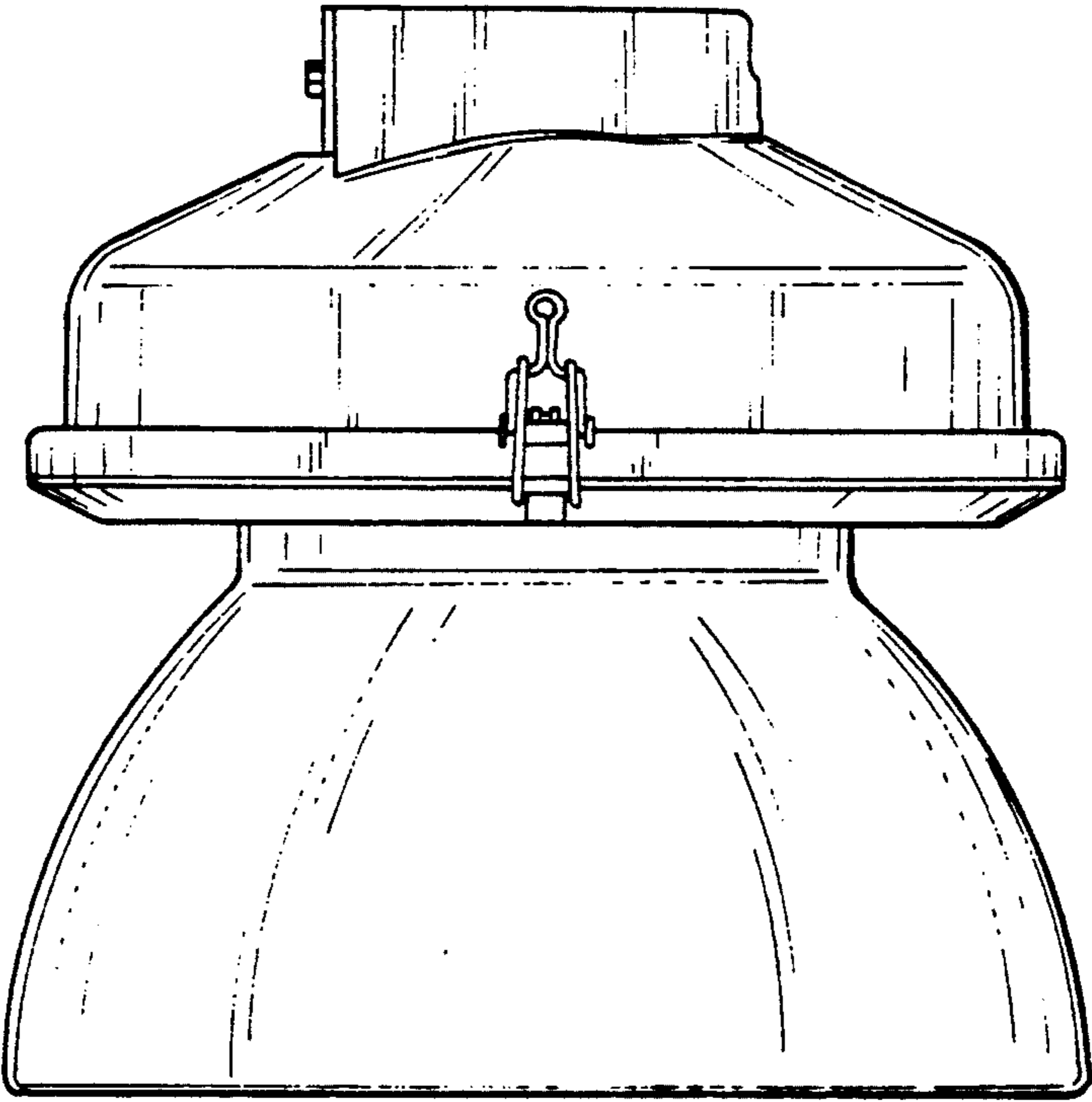

fig-4

fig-5



fig-6

