



US00D348428S

# United States Patent [19]

[11] Patent Number: **Des. 348,428**

Gallagher et al.

[45] Date of Patent: **\*\* Jul. 5, 1994**

[54] **BATTERY CHARGER WITH MEANS FOR SUPPORTING DUAL BATTERY PACKS**

*Assistant Examiner—Joel Sincavage  
Attorney, Agent, or Firm—Jones, Day, Reavis & Pogue*

[75] Inventors: **P. Sean Gallagher**, Park Forest;  
**William H. Schultz**, Northbrook,  
both of Ill.

[57] **CLAIM**

The ornamental design for a battery charger with means for supporting dual battery packs, as shown and described.

[73] Assignee: **Skil and S-B Power Tool Company**,  
Chicago, Ill.

**DESCRIPTION**

[\*\*] Term: **14 Years**

FIG. 1 is a front view of the battery charger with means for supporting dual battery packs;  
FIG. 2 is a back view of the battery charger with means for supporting dual battery packs;  
FIG. 3 is a right side view of the battery charger with means for supporting dual battery packs;  
FIG. 4 is a left side view of the battery charger with means for supporting dual battery packs;  
FIG. 5 is a top view of the battery charger with means for supporting dual battery packs;  
FIG. 6 is a bottom plan view of the battery charger with means for supporting dual battery packs; and,  
FIG. 7 is a perspective view of the battery charger with means for supporting dual battery packs.

[21] Appl. No.: **743,563**

[22] Filed: **Aug. 9, 1991**

[52] U.S. Cl. .... **D13/108**

[58] Field of Search ..... **320/2, 3, 4, 5;  
D13/107, 108; D14/240**

[56] **References Cited**

**U.S. PATENT DOCUMENTS**

D. 301,455 6/1989 Hotsumi et al. .... **D13/108**  
4,829,226 5/1989 Nakamura et al. .... **D13/107 X**

*Primary Examiner—Wallace R. Burke*

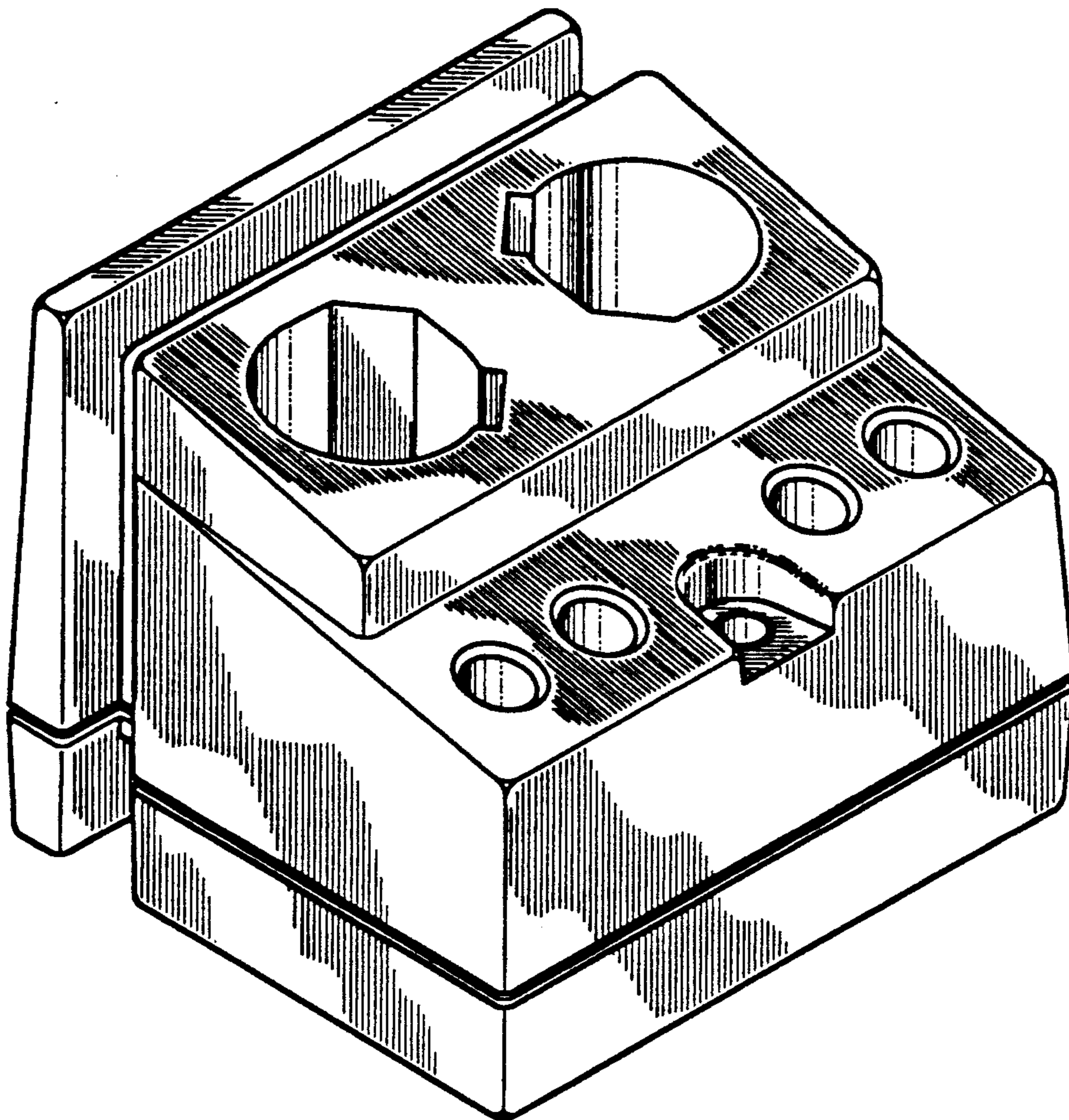

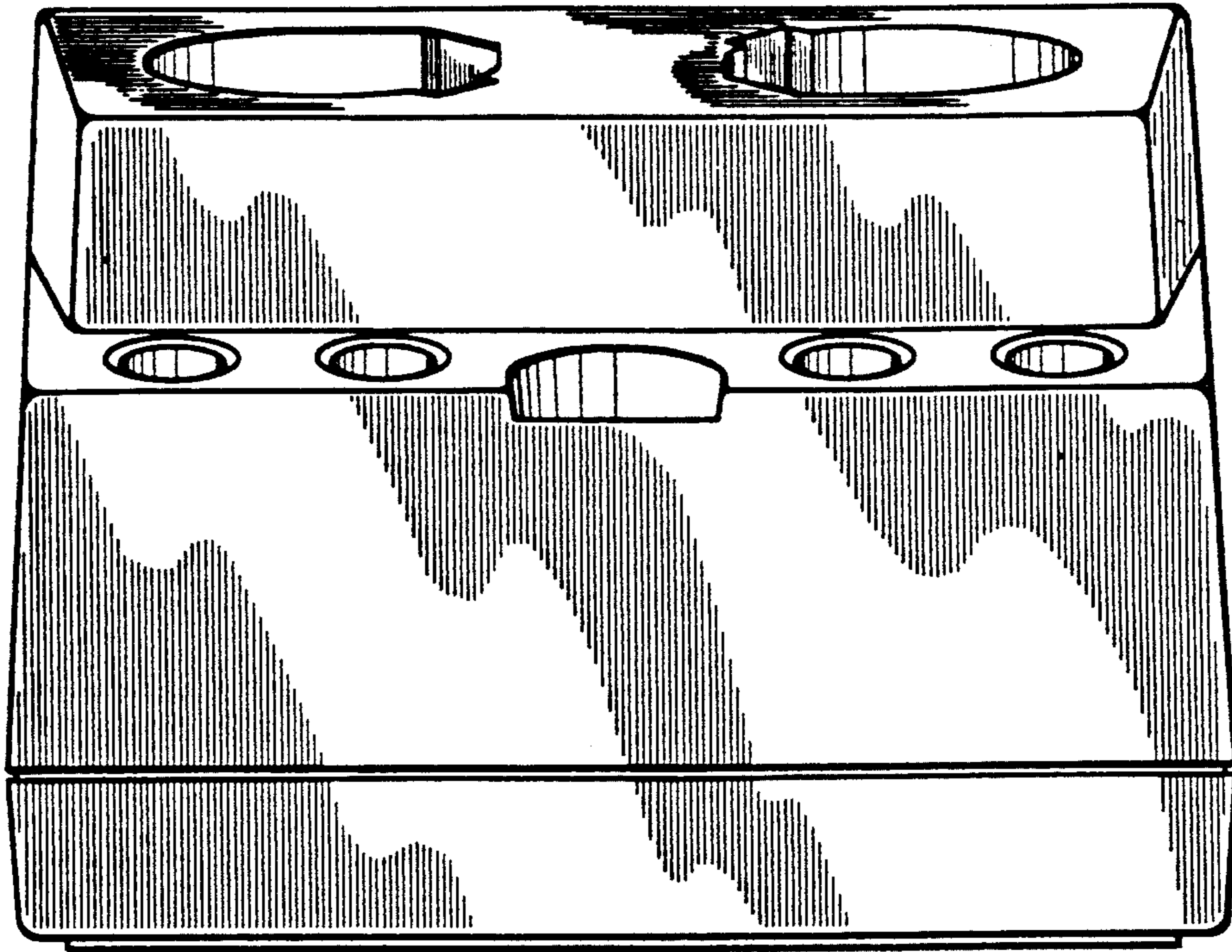

Fig.1

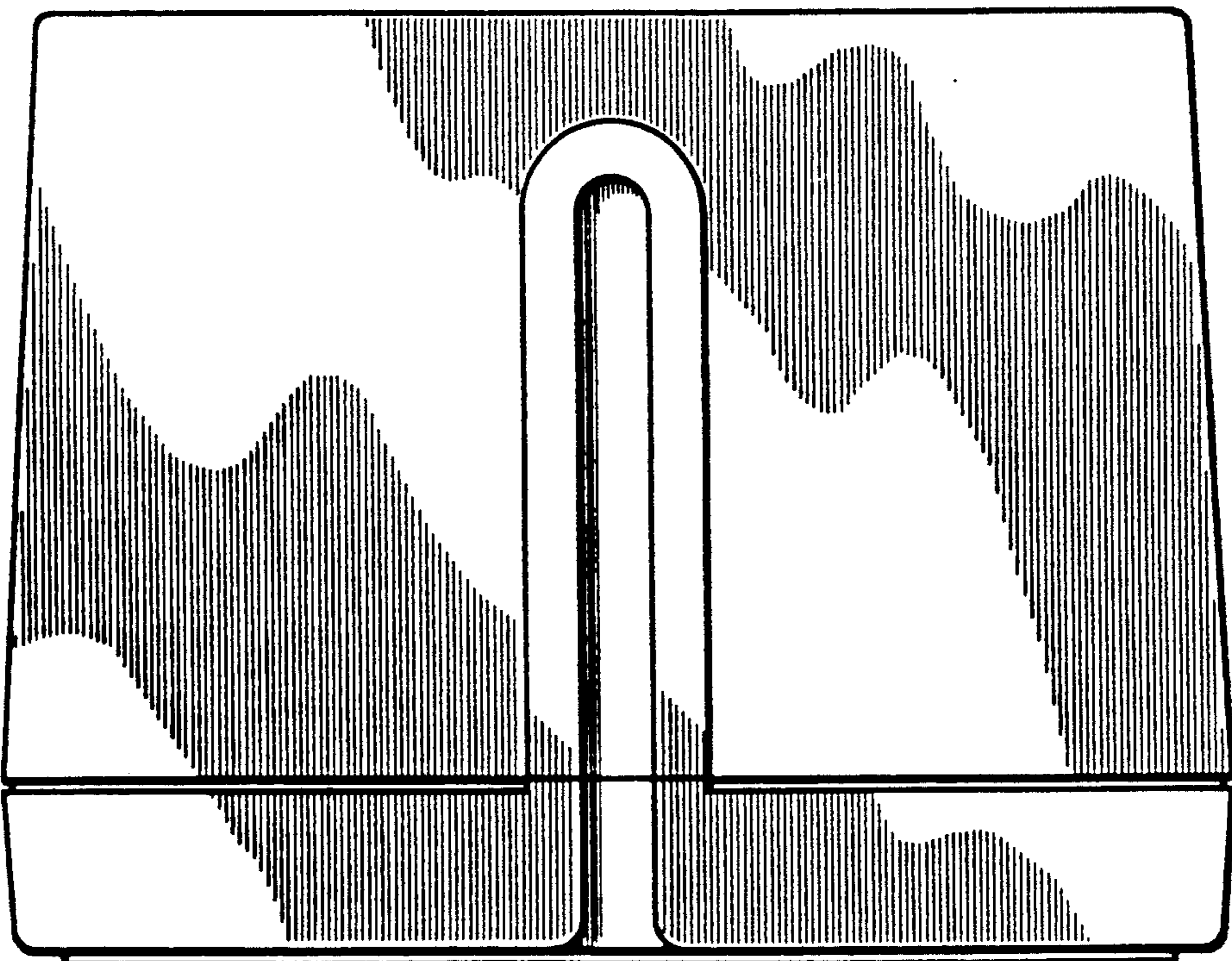

Fig.2

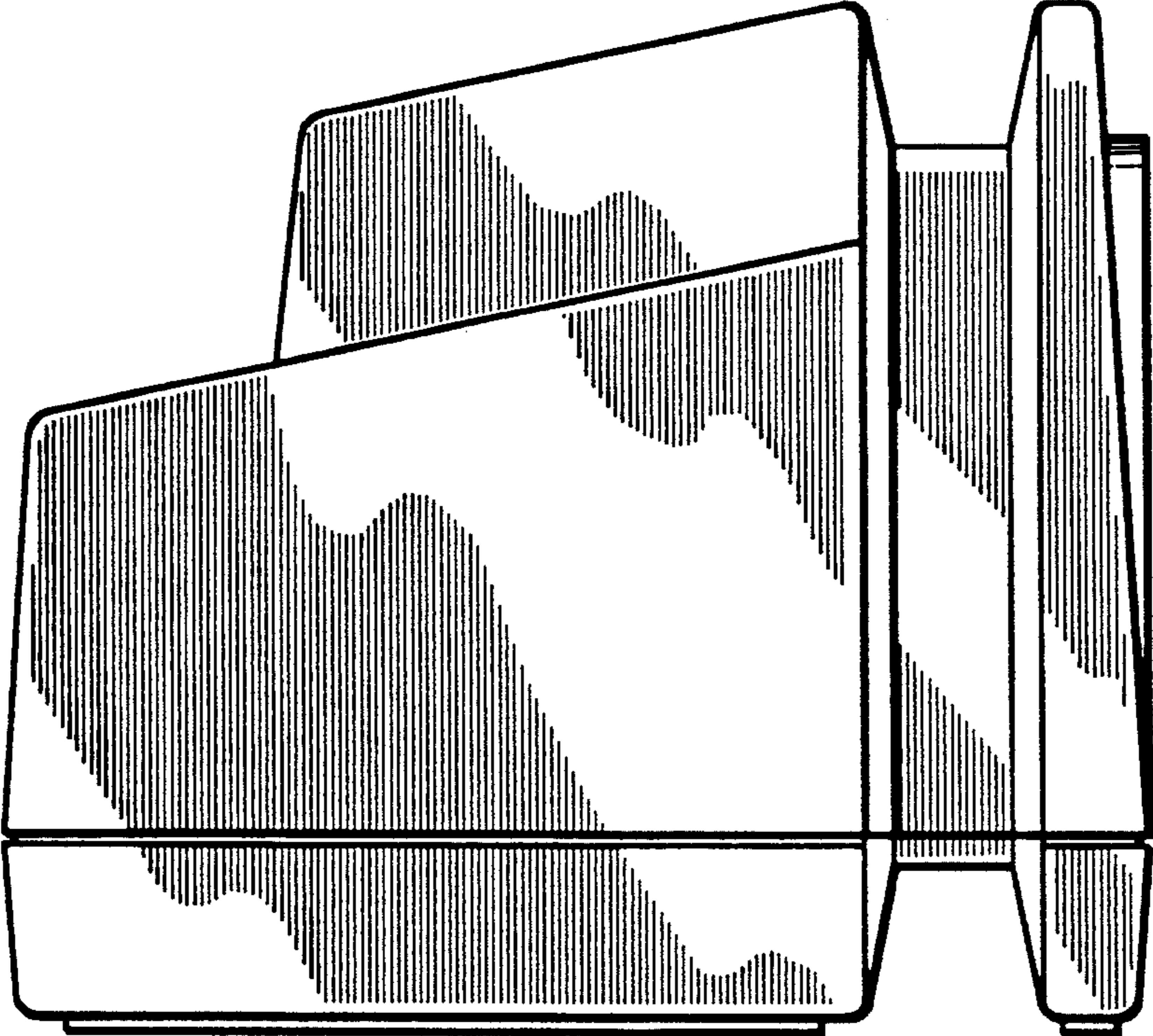

Fig.3

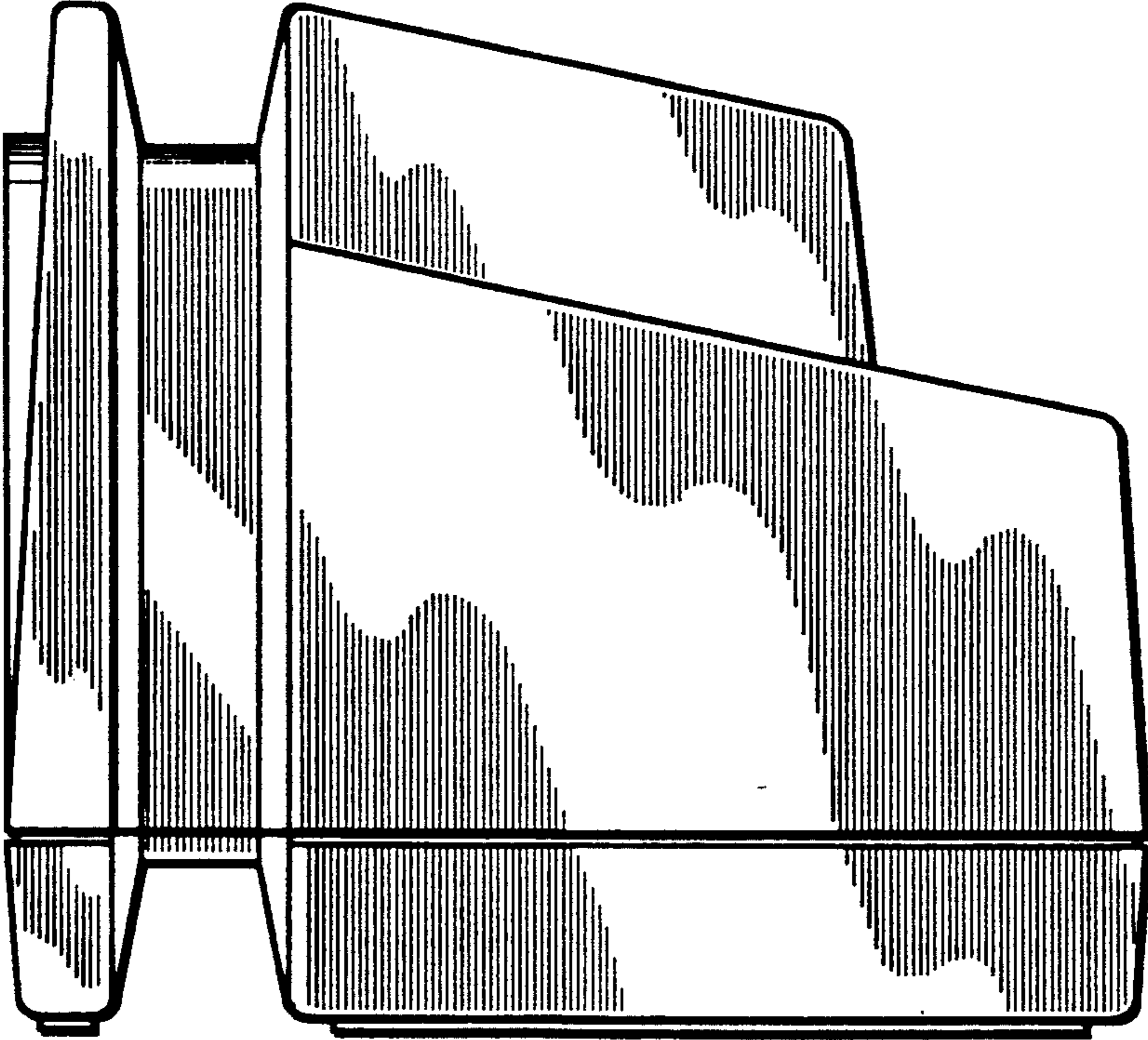

Fig.4

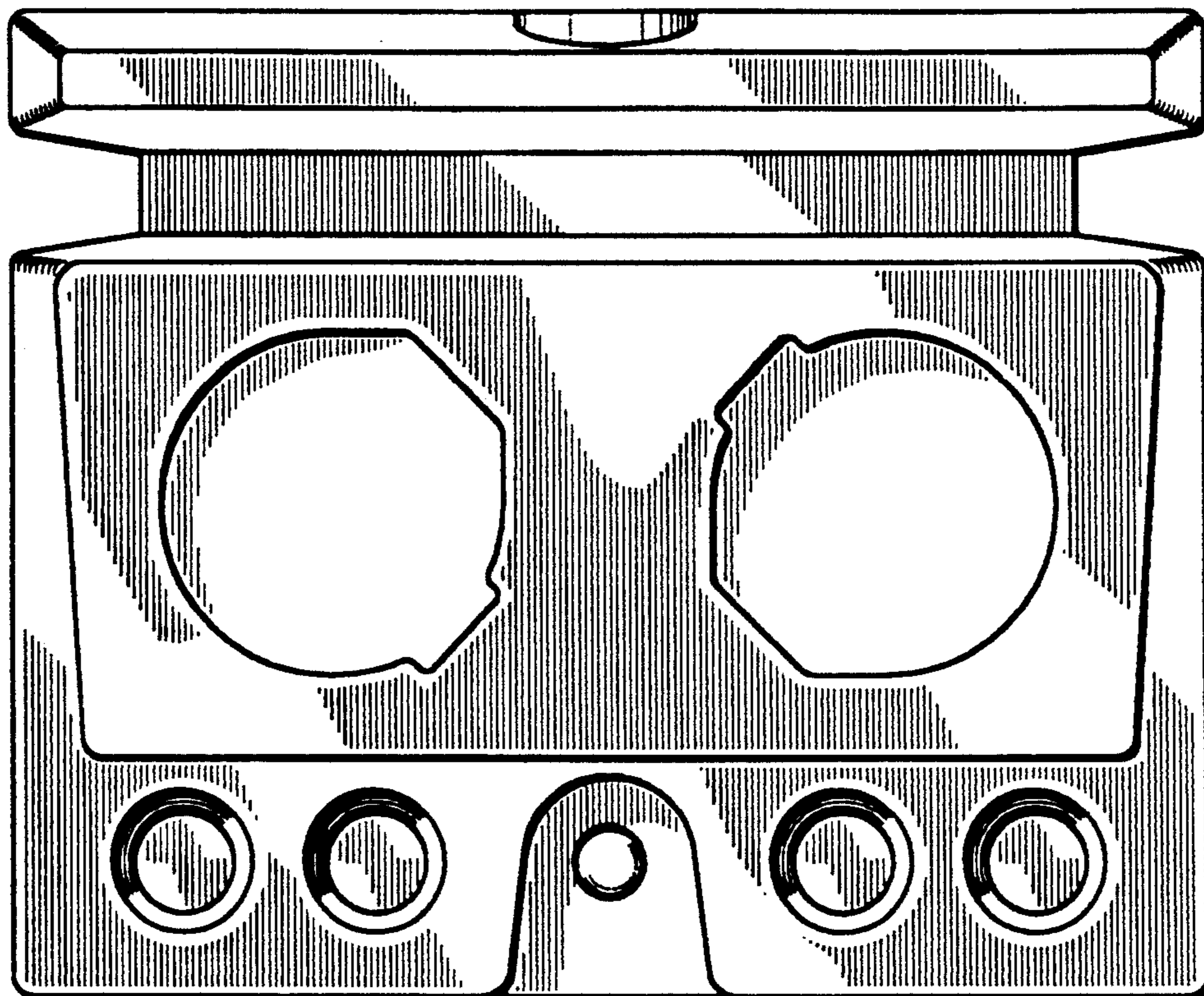

Fig.5

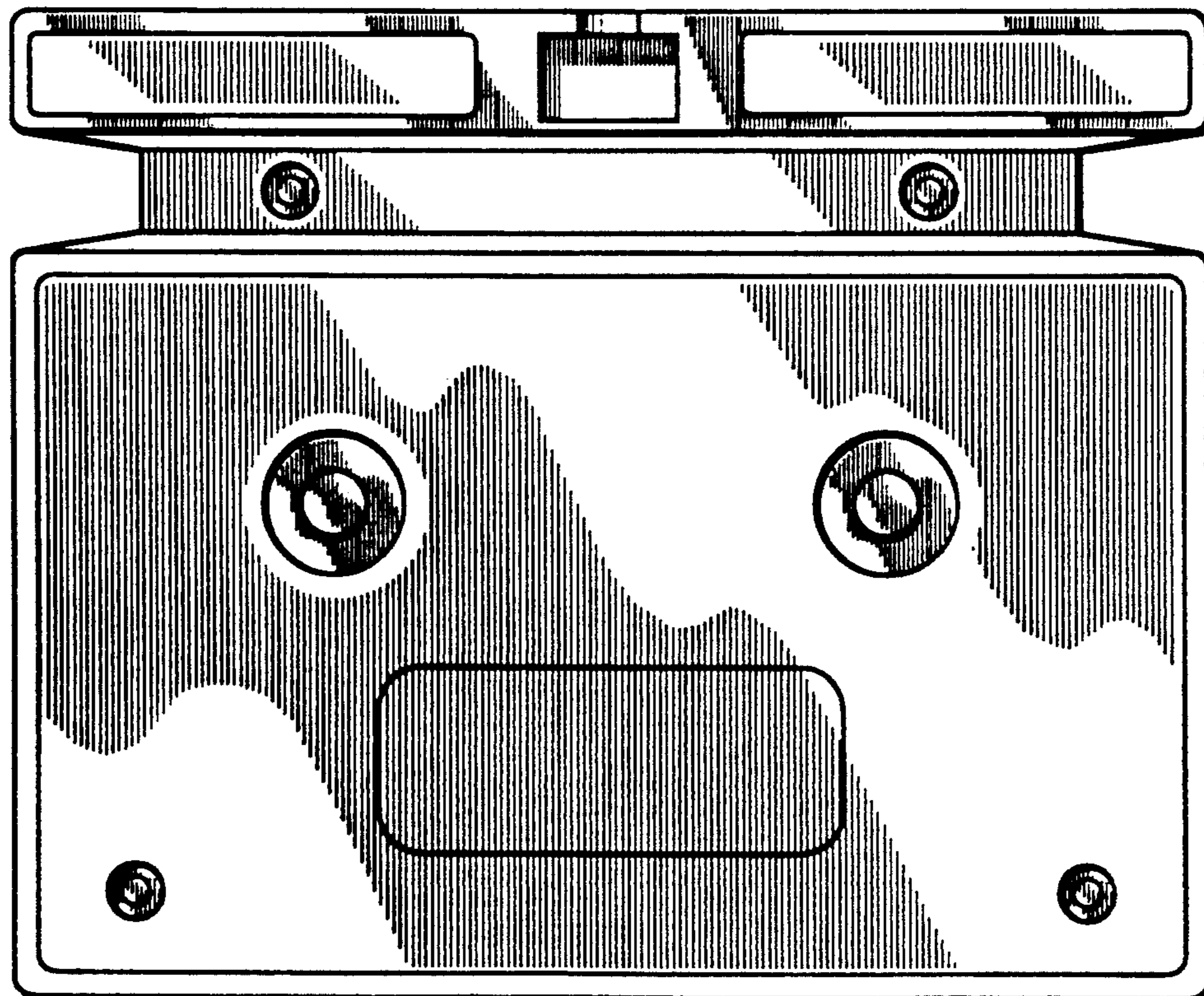

Fig.6

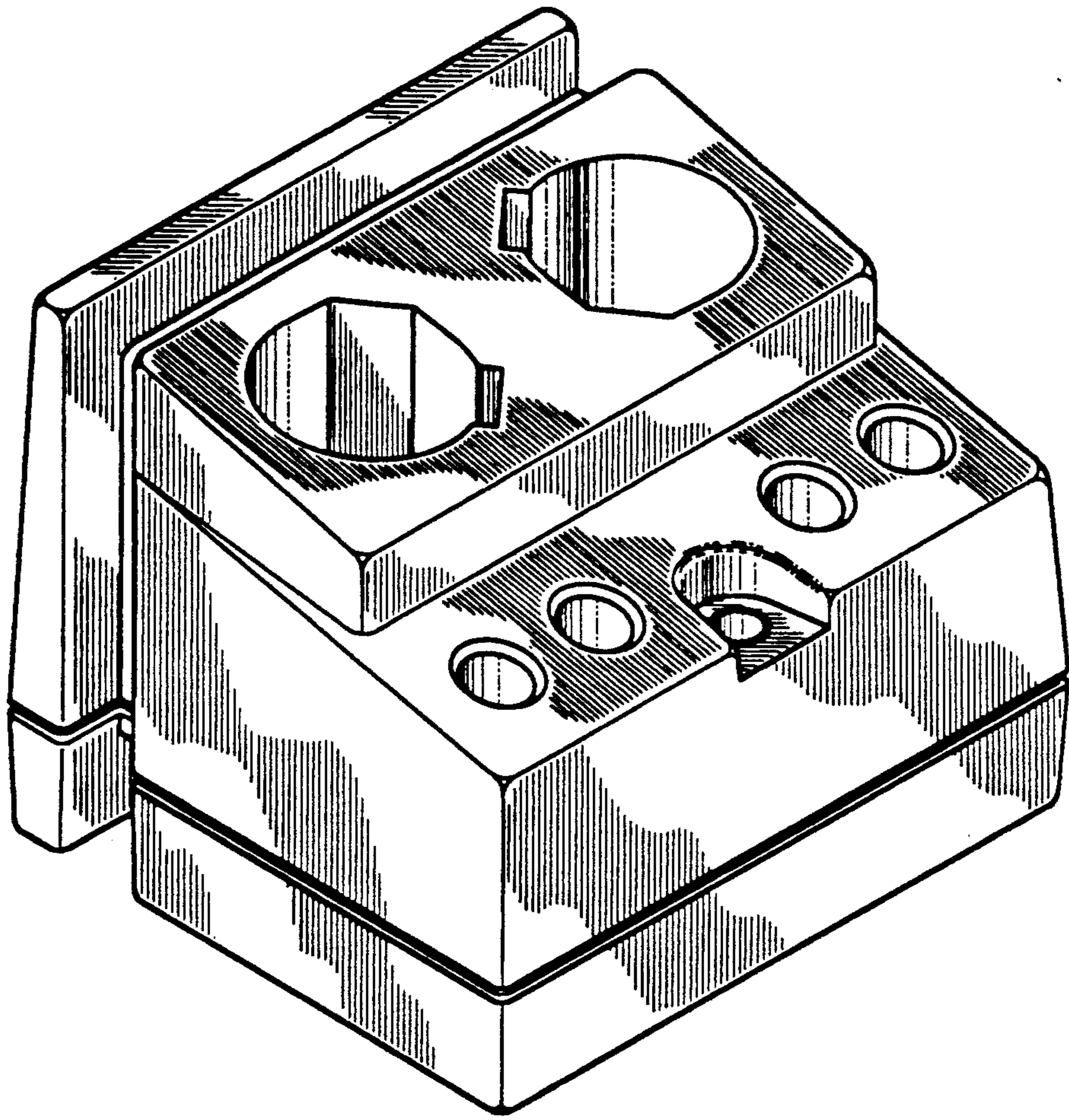

Fig.7