



US00D348411S

# United States Patent [19]

[11] Patent Number: **Des. 348,411**

**Hedgewick**

[45] Date of Patent: **\*\* Jul. 5, 1994**

[54] **PAVEMENT MARKER**

1,574,738 2/1926 Cretney ..... 404/15  
3,409,344 11/1968 Balint et al. .... D10/113

[75] Inventor: **Peter Hedgewick, Windsor, Canada**

*Primary Examiner*—Wallace R. Burke  
*Assistant Examiner*—Marcus Jackson  
*Attorney, Agent, or Firm*—Gifford, Groh, Sprinkle,  
Patmore and Anderson

[73] Assignee: **Pac-Tec, Inc., Heath, Ohio**

[\*\*] Term: **14 Years**

[21] Appl. No.: **2,741**

[57] **CLAIM**

[22] Filed: **Dec. 21, 1992**

The ornamental design for pavement marker, as shown and described.

[52] U.S. Cl. .... **D10/113**

[58] Field of Search ..... 40/612, 613; 116/63 C,  
116/63 T, 63 P; 404/6, 7, 8, 9, 10, 11, 12, 13, 14,  
15, 16; D10/109, 111, 113

**DESCRIPTION**

[56] **References Cited**

**U.S. PATENT DOCUMENTS**

- D. 219,845 2/1971 Hedgewick ..... D10/113
- D. 267,933 2/1983 Zuckinbill ..... D10/113
- D. 311,704 10/1990 May ..... D10/113
- D. 328,262 7/1992 Sakko ..... D10/113

FIG. 1 is a perspective view of a compact pavement marker showing a new design and with the broken line showing for illustrative purposes only and forming no part of the claimed design;  
FIG. 2 is a top elevational view thereof;  
FIG. 3 is a left side elevational view, with the opposite side being a mirror image;  
FIG. 4 is a front elevational view thereof; and,  
FIG. 5 is a bottom elevational view thereof.

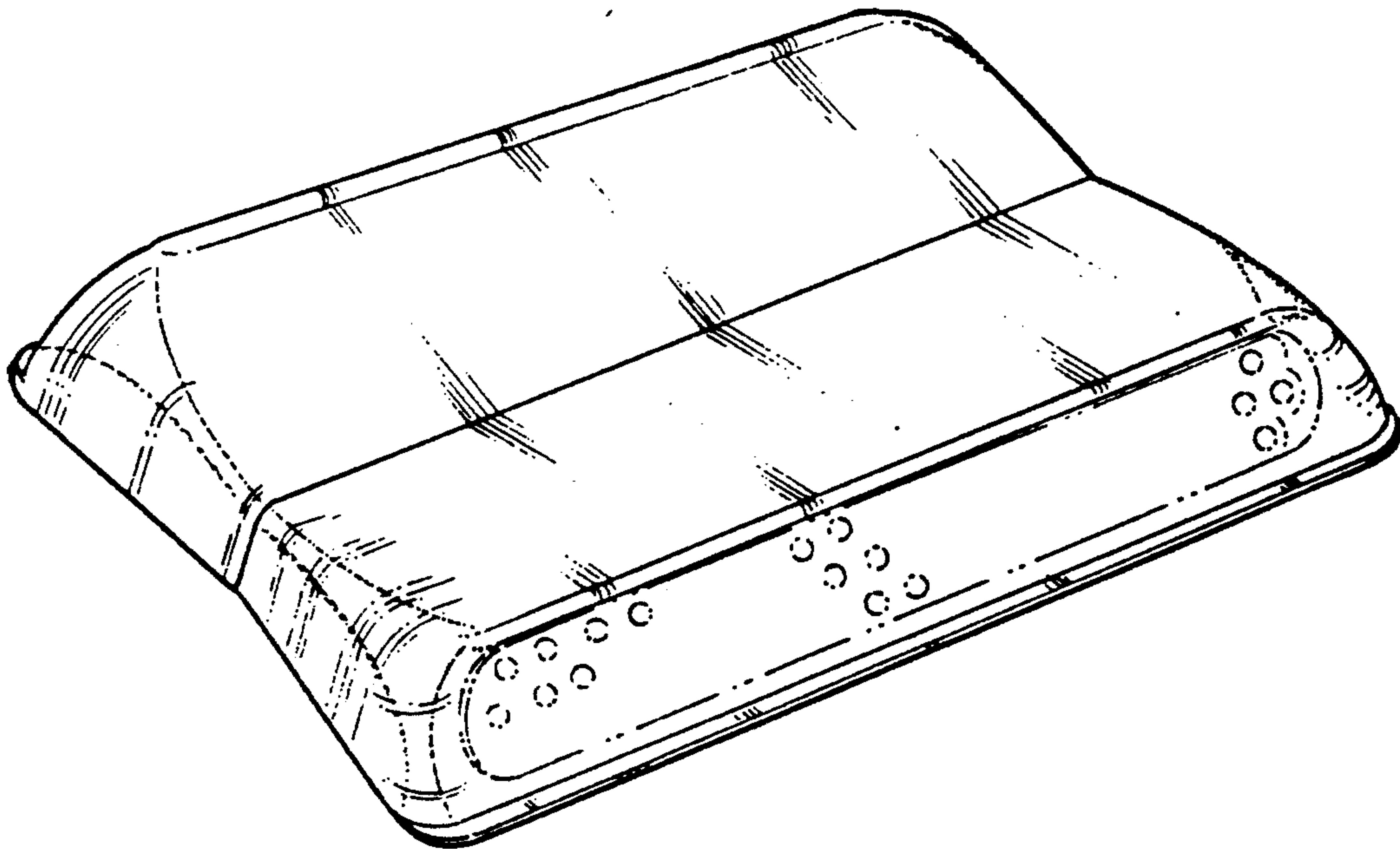

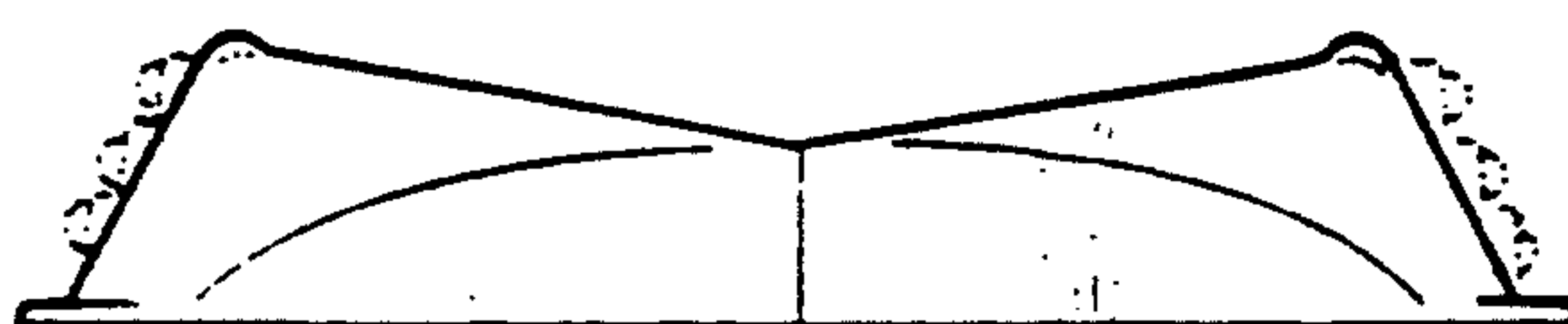
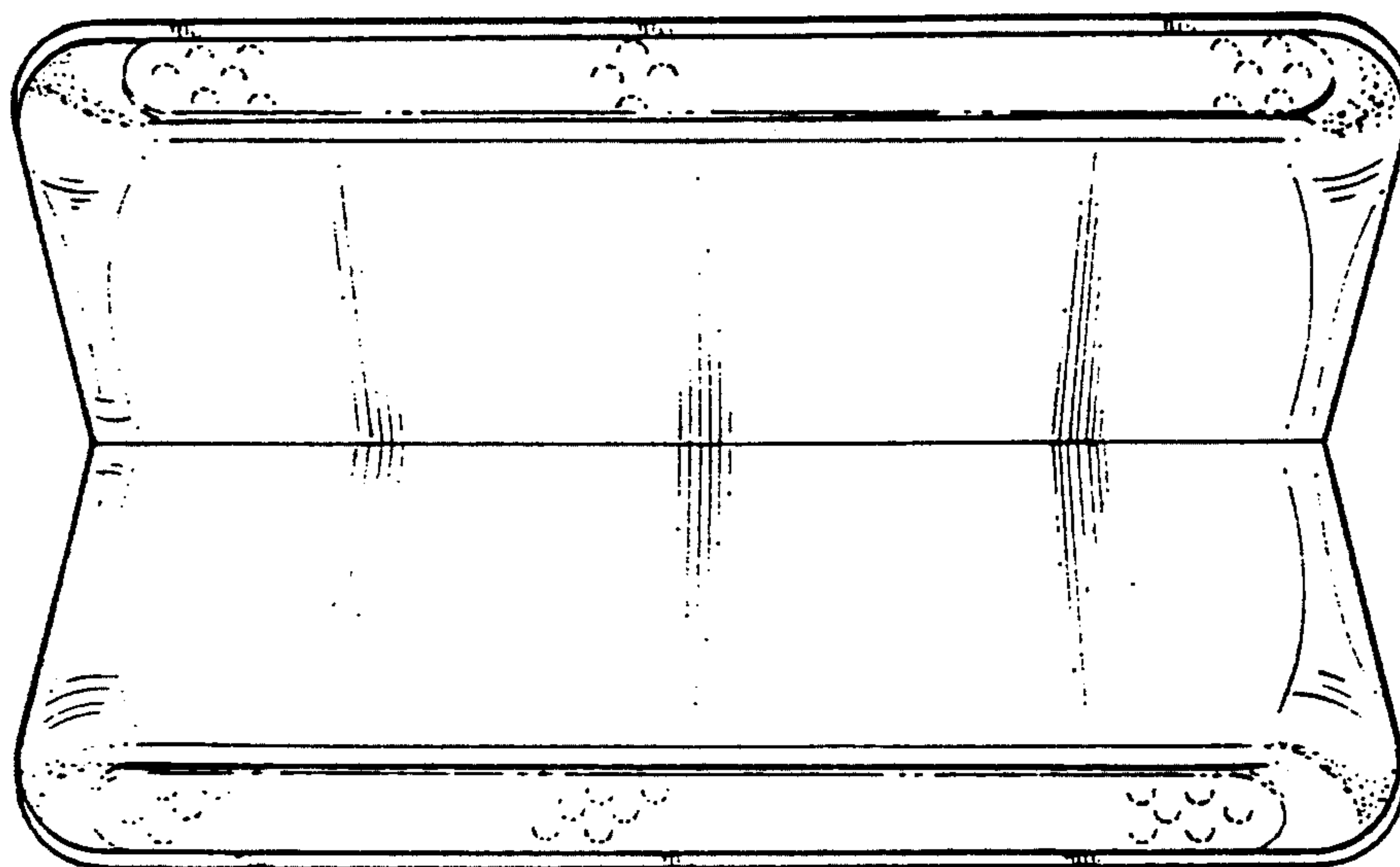
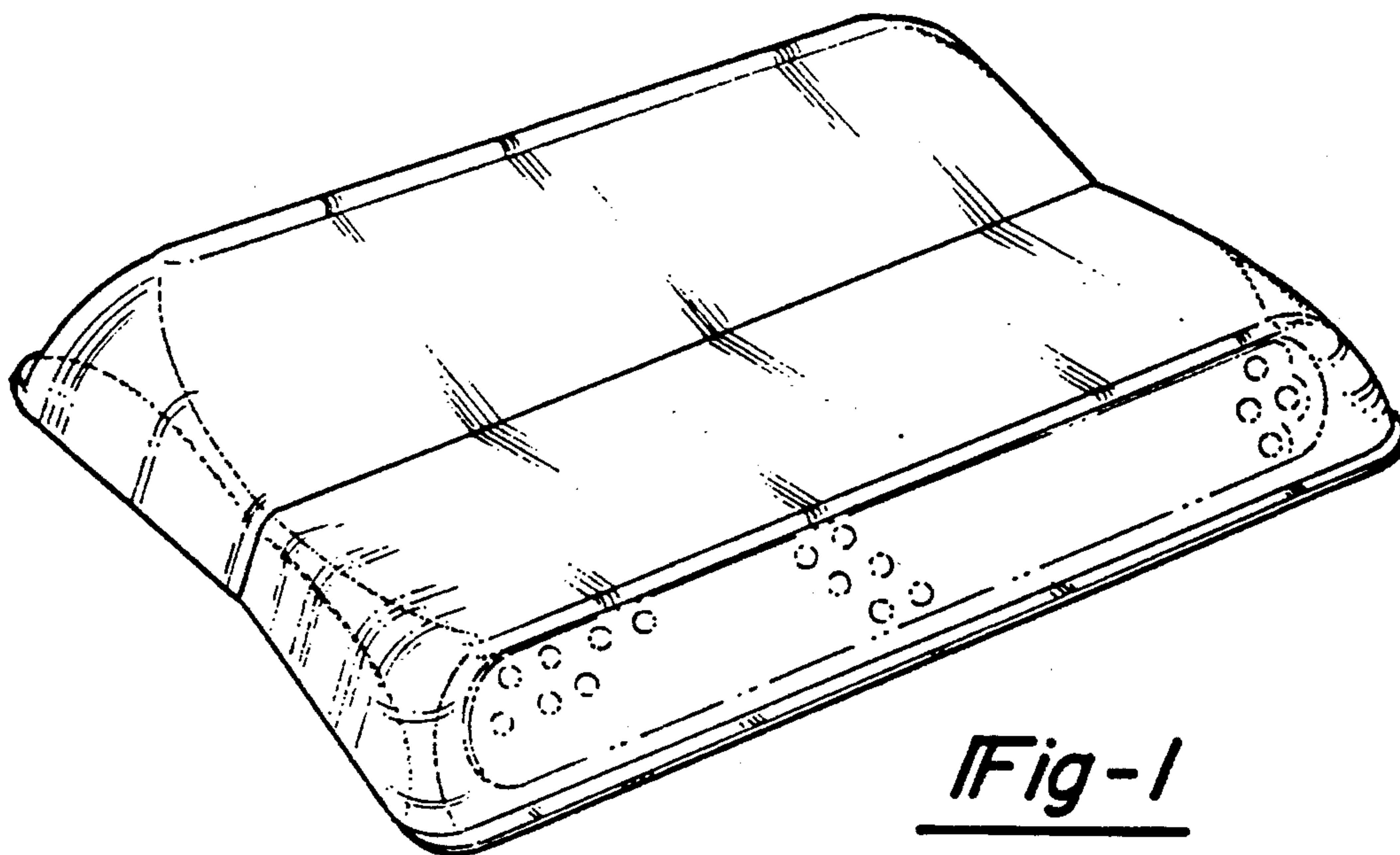

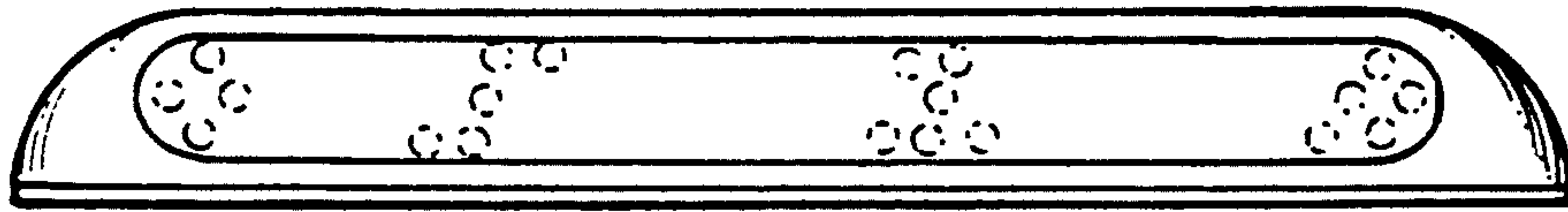

Fig-4

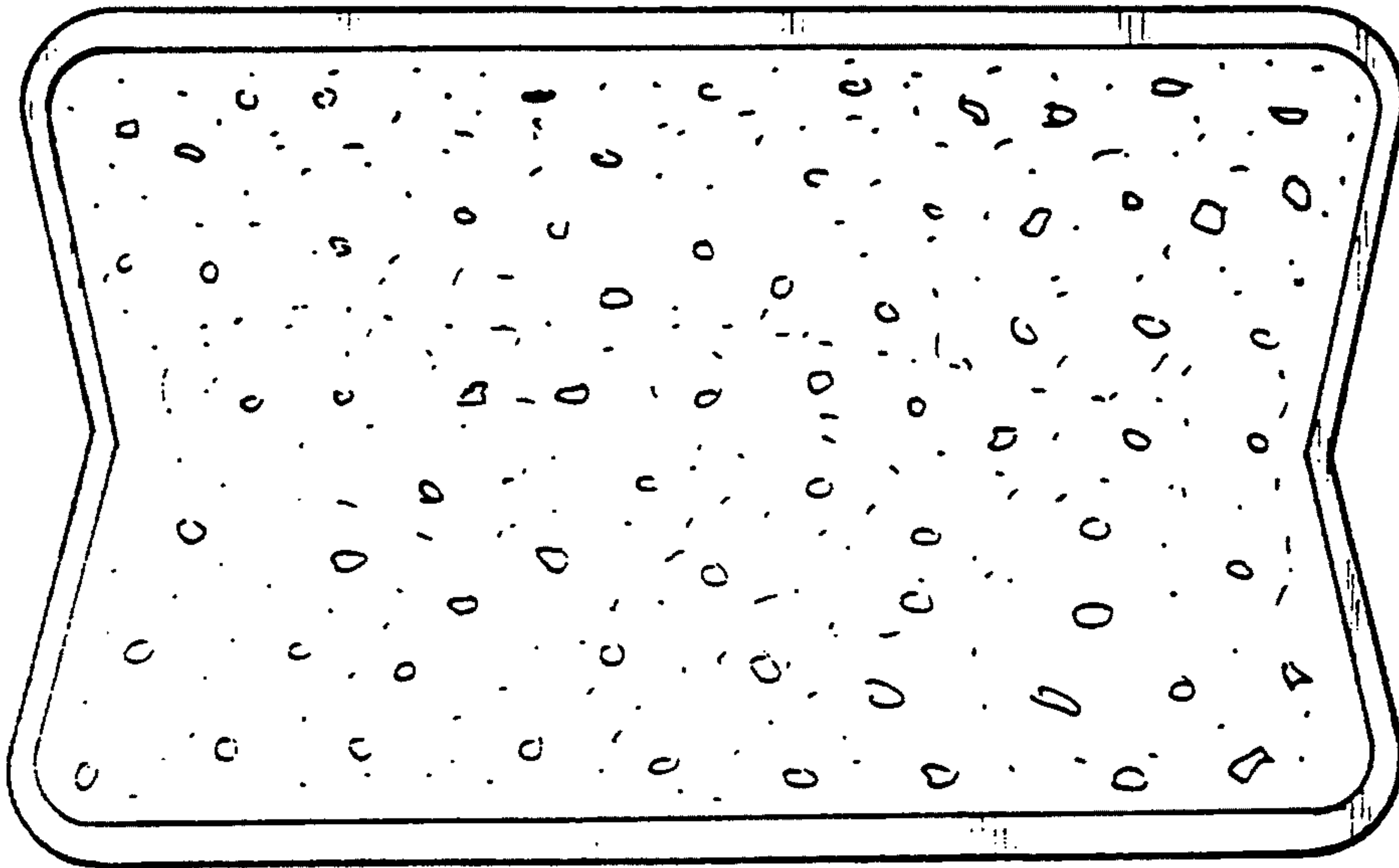

Fig-5