



US00D348244S

United States Patent [19]

[11] Patent Number: **Des. 348,244**

Schlangen et al.

[45] Date of Patent: **** Jun. 28, 1994**

- [54] **DUAL PERSONALIZED WATERCRAFT**
- [75] Inventors: **Phillip E. Schlangen; Raymond J. Buresch**, both of Minneapolis, Minn.
- [73] Assignee: **Hydro-Bikes, Inc.**, Minneapolis, Minn.
- [**] Term: **14 Years**
- [21] Appl. No.: **107**
- [22] Filed: **Oct. 1, 1992**
- [52] U.S. Cl. **D12/306; D12/304**
- [58] Field of Search **114/61; 440/14, 13, 440/26; D12/300, 304, 306**

- 4,968,274 11/1990 Gregory .
- 5,127,855 7/1992 Heywood 440/14
- 5,244,886 7/1993 Cunningham .

OTHER PUBLICATIONS

Scientific American, "Human Powered Watercraft" brochure Dec., 1986.

Primary Examiner—Kay H. Chin

[57] CLAIM

The ornamental design for a dual personalized watercraft, as shown and described.

DESCRIPTION

FIG. 1 is a top plan view of a dual personalized watercraft showing our new design;
 FIG. 2 is a right side elevational view thereof;
 FIG. 3 is a left side elevational view thereof;
 FIG. 4 is a sectional view taken along the line 4—4 of FIG. 1;
 FIG. 5 is a sectional view taken along the line 5—5 of FIG. 1;
 FIG. 6 is a sectional view taken along the line 6—6 of FIG. 1;
 FIG. 7 is an enlarged front elevational view thereof;
 FIG. 8 is an enlarged rear elevational view thereof; and,
 FIG. 9 is a bottom plan view thereof.

[56] **References Cited**
U.S. PATENT DOCUMENTS

- D. 287,847 1/1987 Bobinac .
- D. 321,854 11/1991 Foley et al. .
- 637,547 11/1899 Clark .
- 1,761,883 6/1930 Froedtert .
- 2,177,074 10/1939 Mattson .
- 3,352,276 11/1967 Zimmerman .
- 3,593,684 7/1971 Cogliano .
- 4,323,352 4/1982 Warren et al. .
- 4,493,657 1/1985 Zeitler .
- 4,698,034 10/1987 Anthonijsz 440/27
- 4,836,298 6/1989 Laboureau .

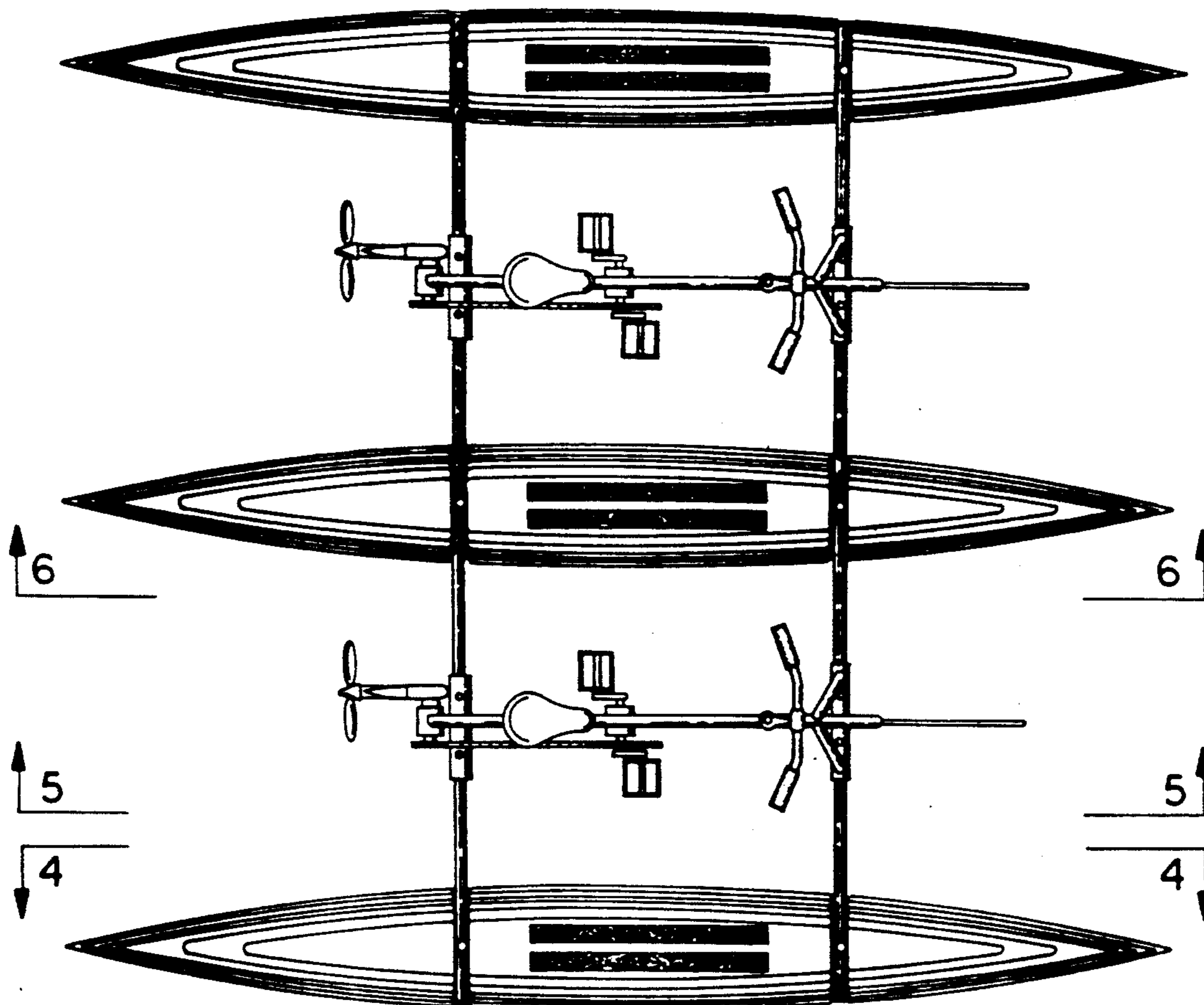

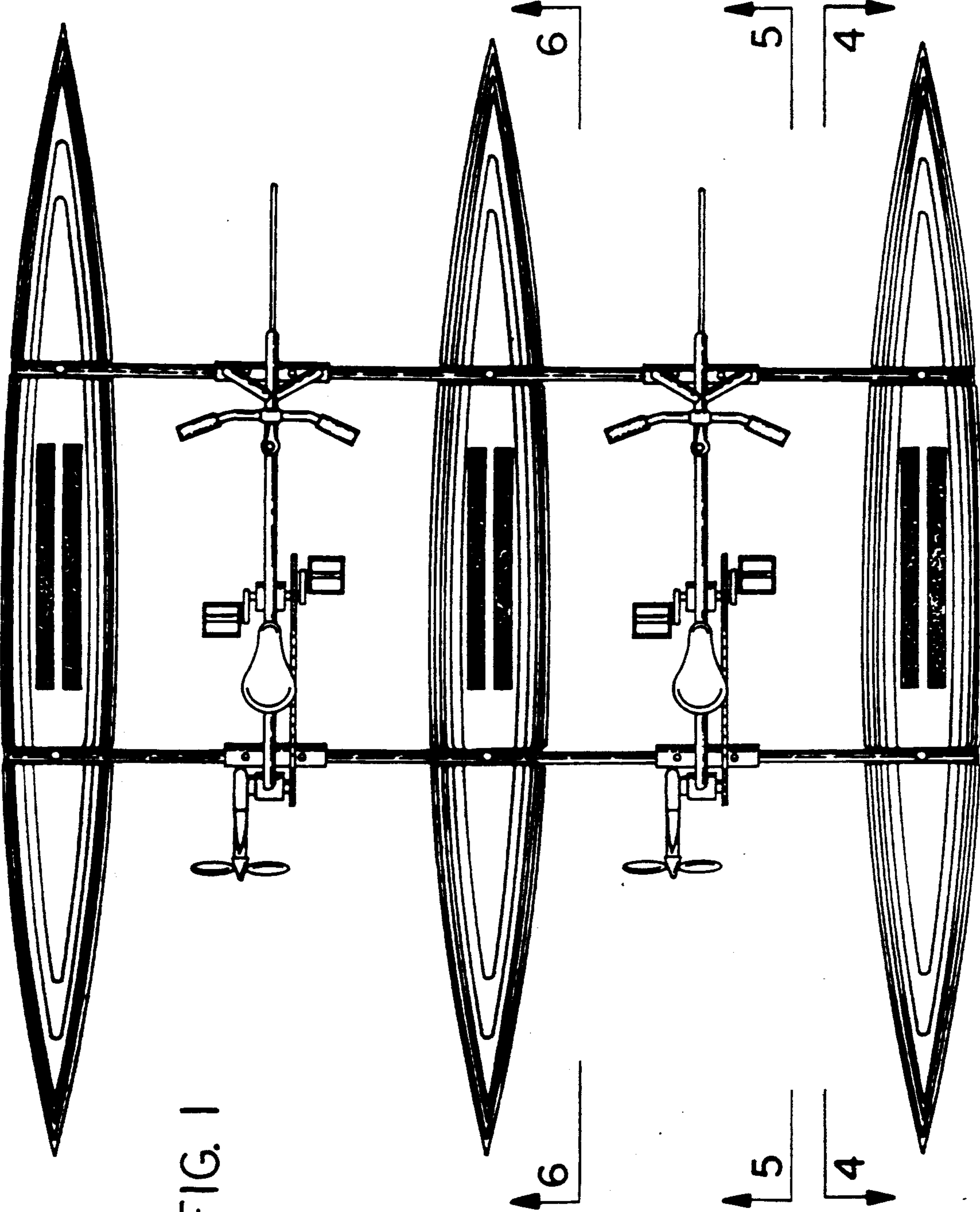

FIG. 1

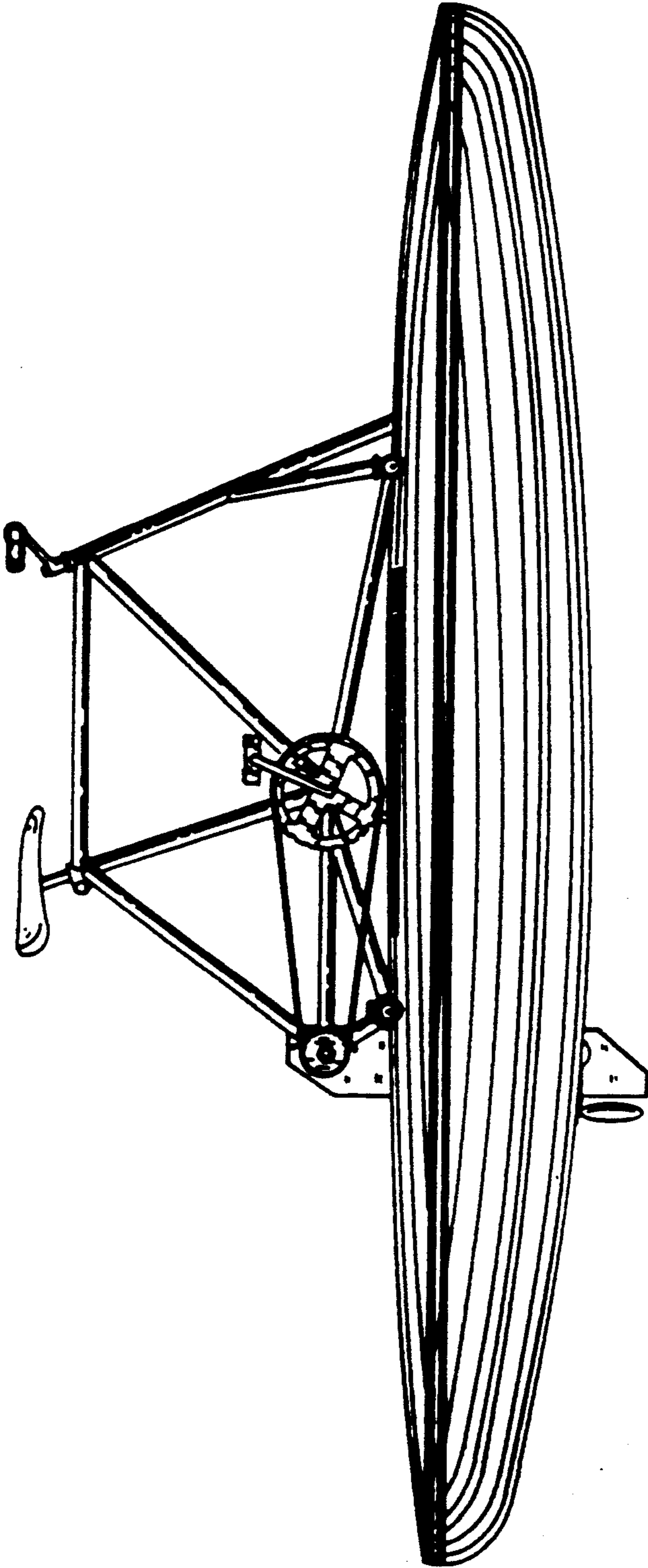

FIG. 2

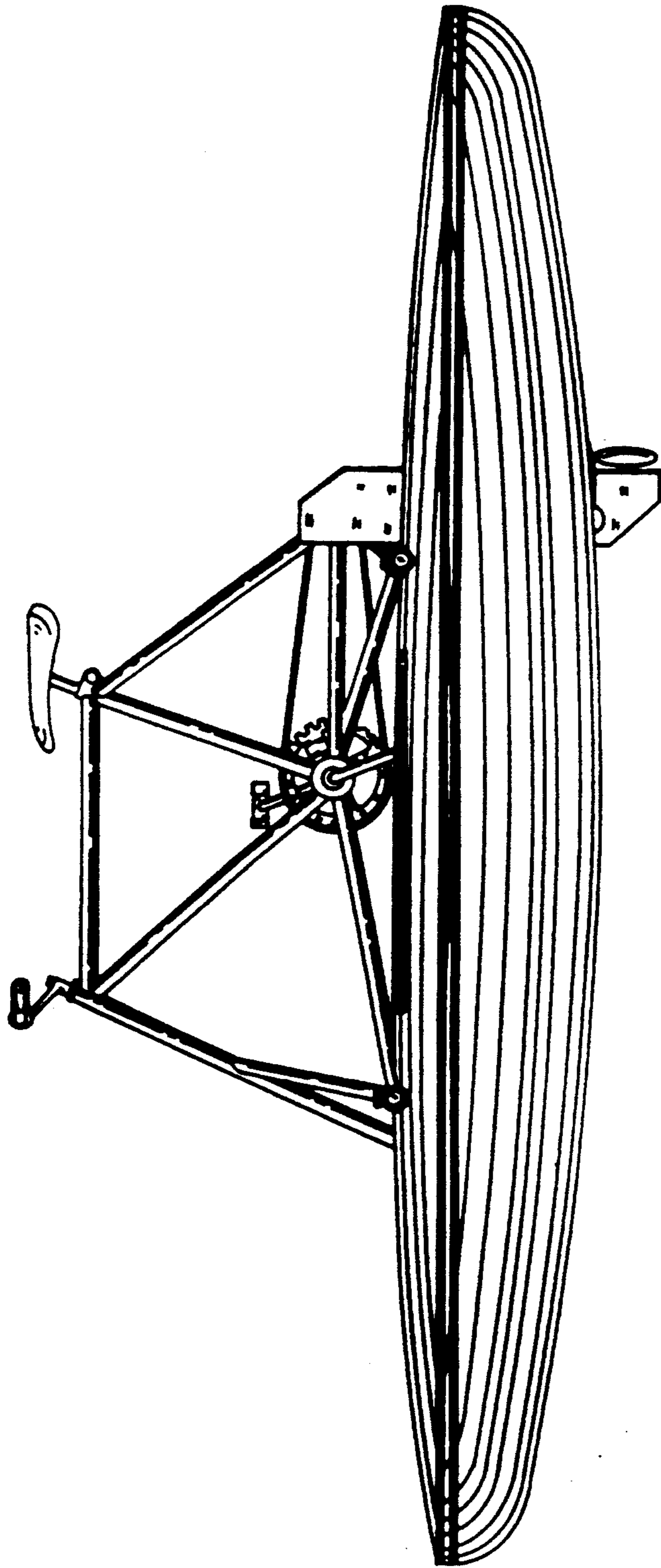

FIG. 3

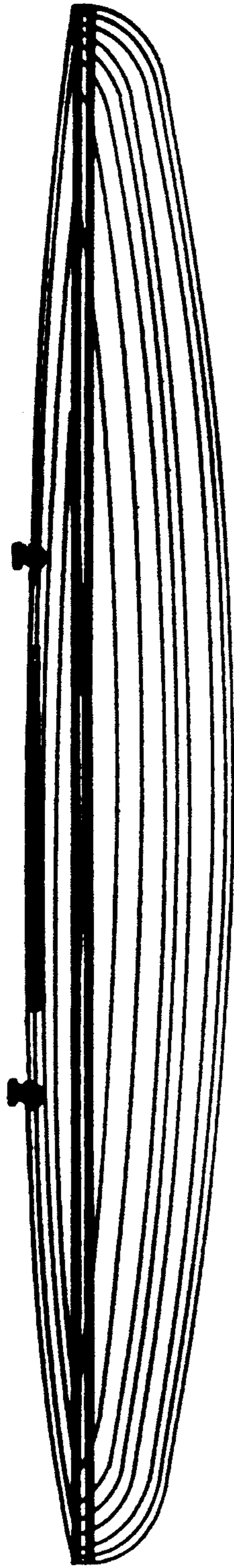

FIG. 4

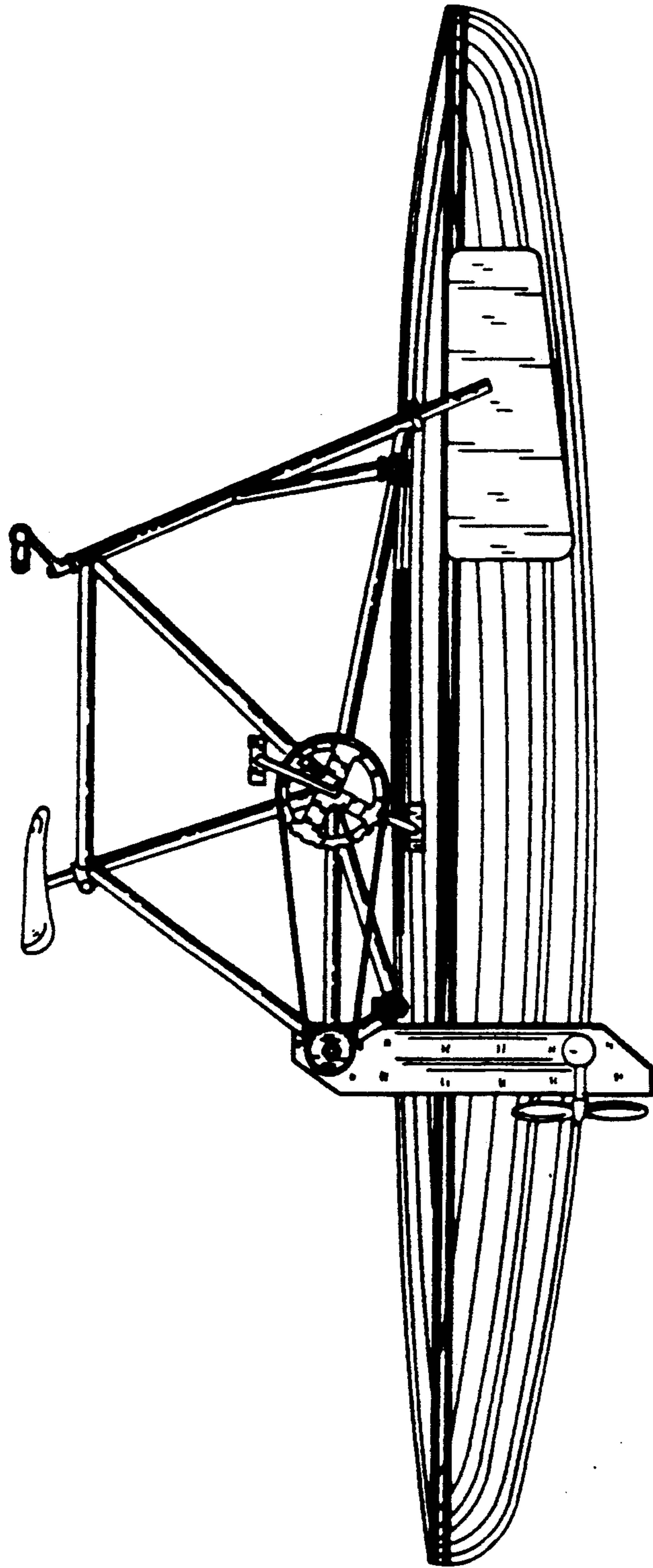

FIG. 5

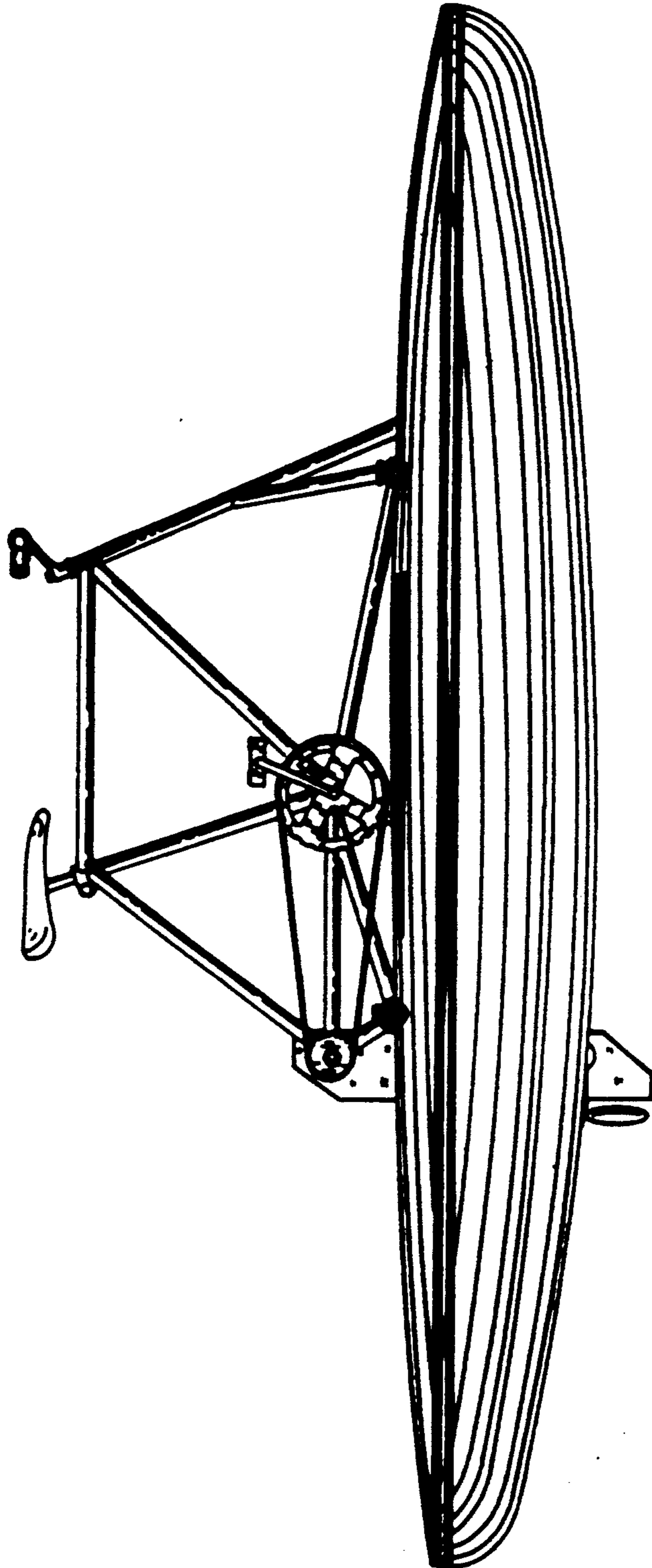

FIG. 6

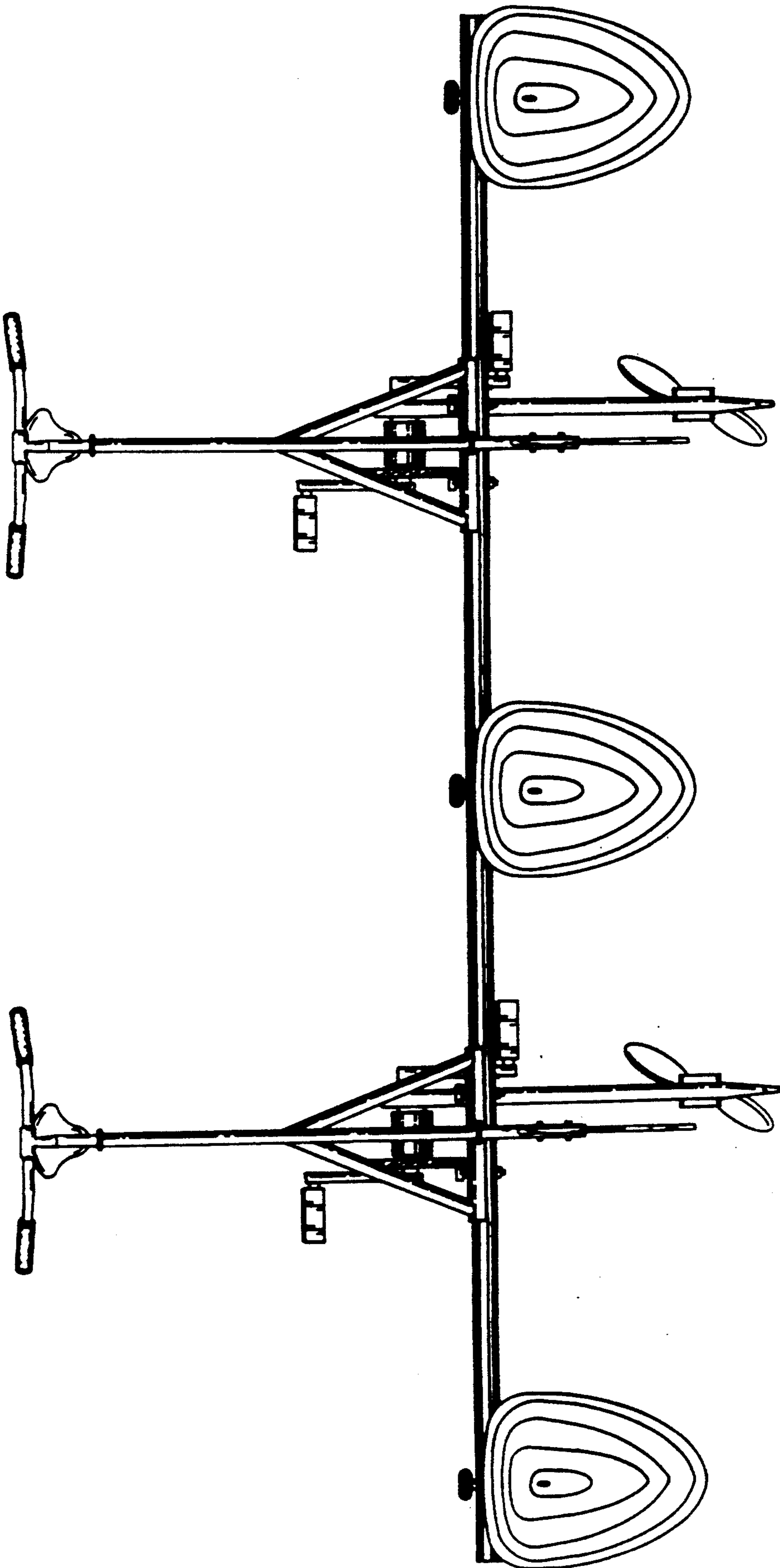

FIG. 7

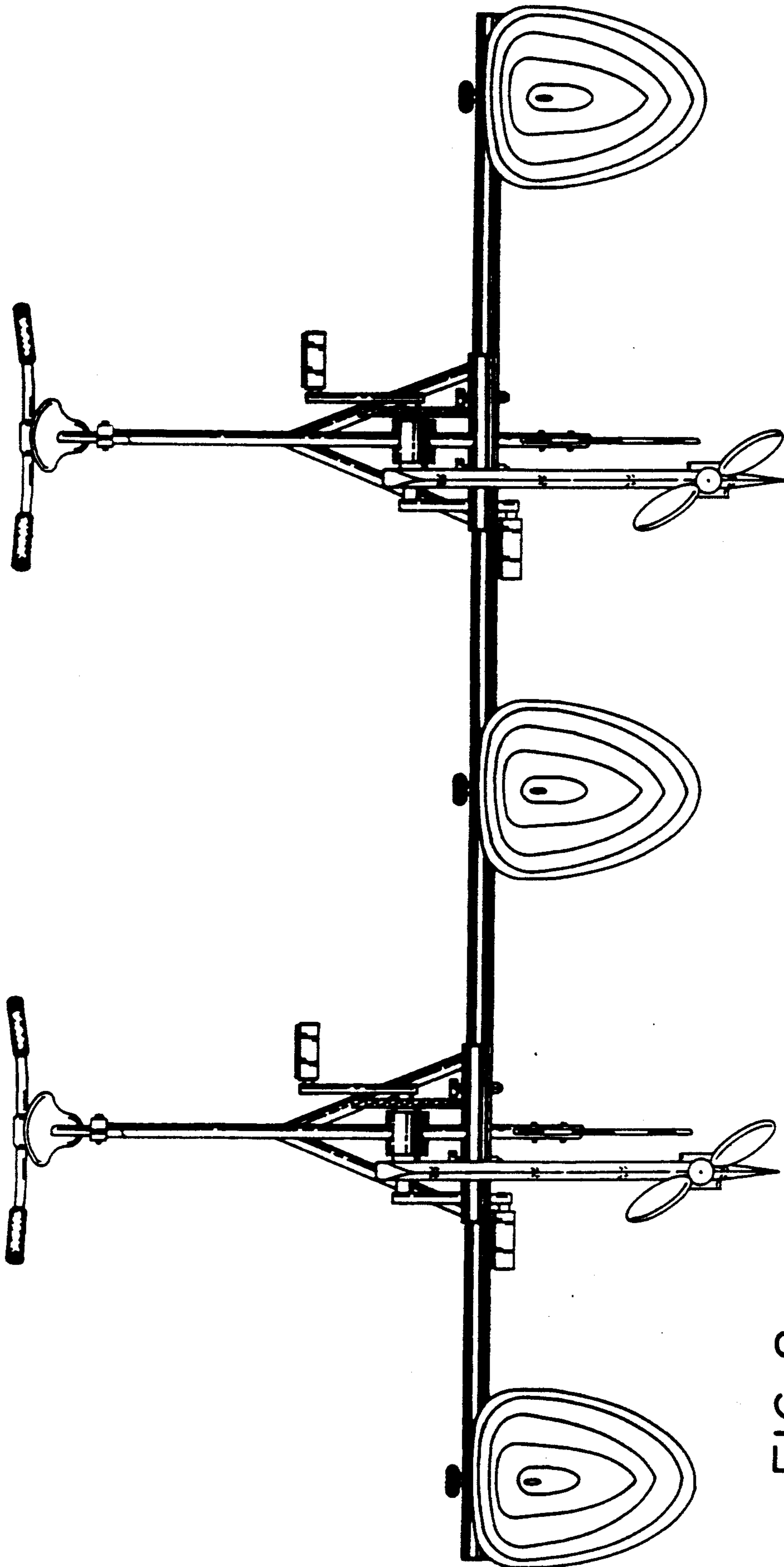

FIG. 8

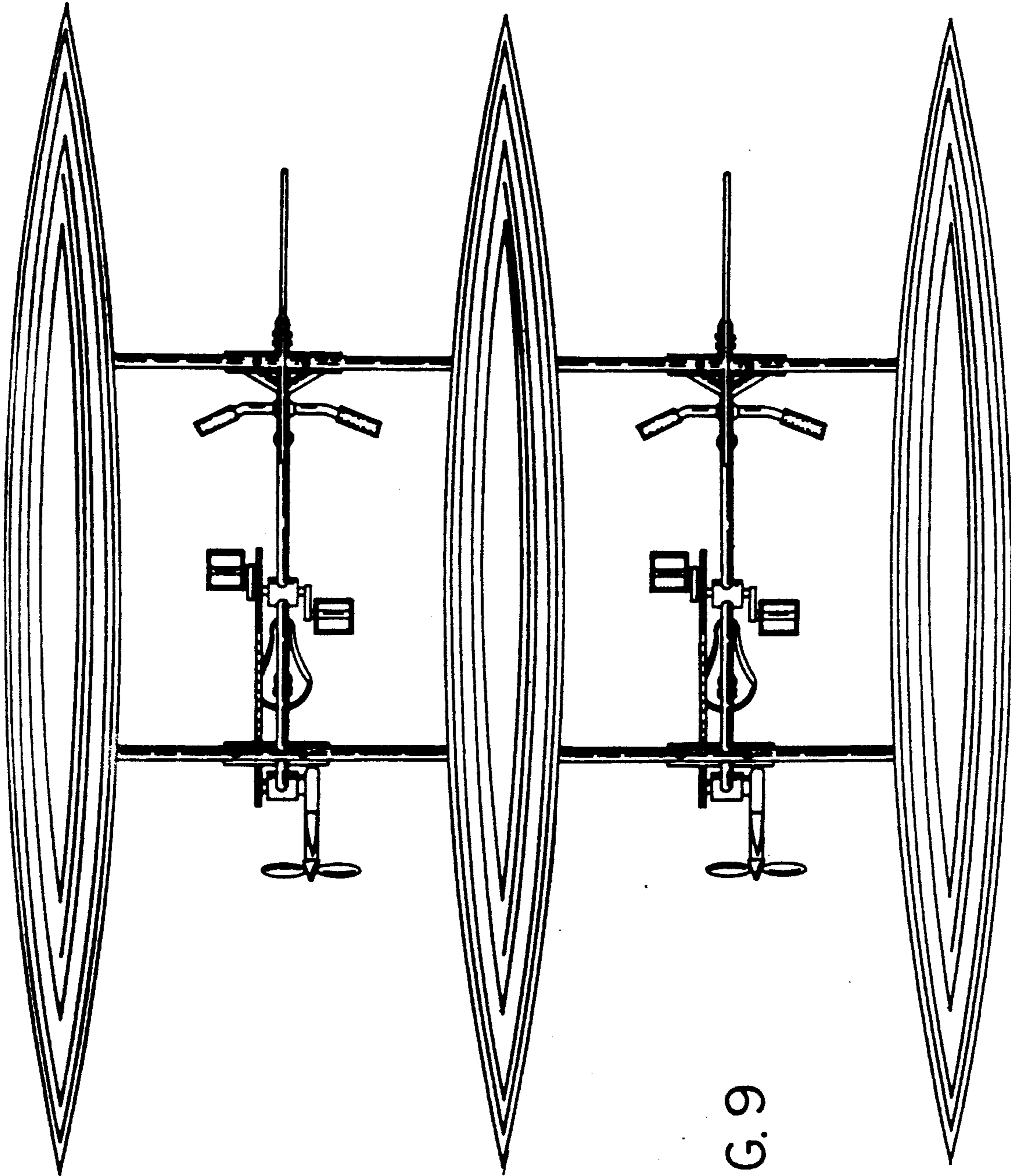

FIG. 9