



US00D348208S

United States Patent [19]
Chen

[11] **Patent Number: Des. 348,208**

[45] **Date of Patent: ** Jun. 28, 1994**

[54] **AUTOMOBILE STEERING WHEEL LOCK**

[76] **Inventor: Ping-Ken Chen**, No. 16, Kanping, Chiku, Tainan Hsing, Taiwan

[**] **Term: 14 Years**

[21] **Appl. No.: 13,429**

[22] **Filed: Sep. 24, 1993**

[52] **U.S. Cl. D8/331**

[58] **Field of Search D8/330-331, D8/333, 339, 341; 70/14, 233, 237-238, 245, 247, 252**

[56] **References Cited**

U.S. PATENT DOCUMENTS

D. 330,500	10/1992	Chen	D8/331
D. 333,970	3/1993	Starmer	D8/331
D. 339,973	10/1993	Chen	D8/331
D. 340,855	11/1993	Wu et al.	D8/331
4,882,920	11/1989	Wu	70/209
4,974,433	12/1990	Wang	70/237 X
5,095,723	3/1992	Lin	70/209 X

FOREIGN PATENT DOCUMENTS

2413710 3/1974 Fed. Rep. of Germany 70/238
223819A 6/1991 United Kingdom 70/238

Primary Examiner—Brian N. Vinson

[57] **CLAIM**

The ornamental design for an automobile steering wheel lock, as shown and described.

DESCRIPTION

FIG. 1 is a top, front, and right side perspective view of an automobile steering wheel lock showing my new design;

FIG. 2 is a front elevational view thereof;

FIG. 3 is a rear elevational view thereof;

FIG. 4 is a left side elevational view thereof;

FIG. 5 is a right side elevational view thereof;

FIG. 6 is a top plan view thereof;

FIG. 7 is a bottom plan view thereof; and,

FIG. 8 is a reduced top, front, and left side perspective view thereof, the broken-line disclosure of a portion of a steering wheel and automobile interior being for illustrative purposes only and forming no part of the claimed design.

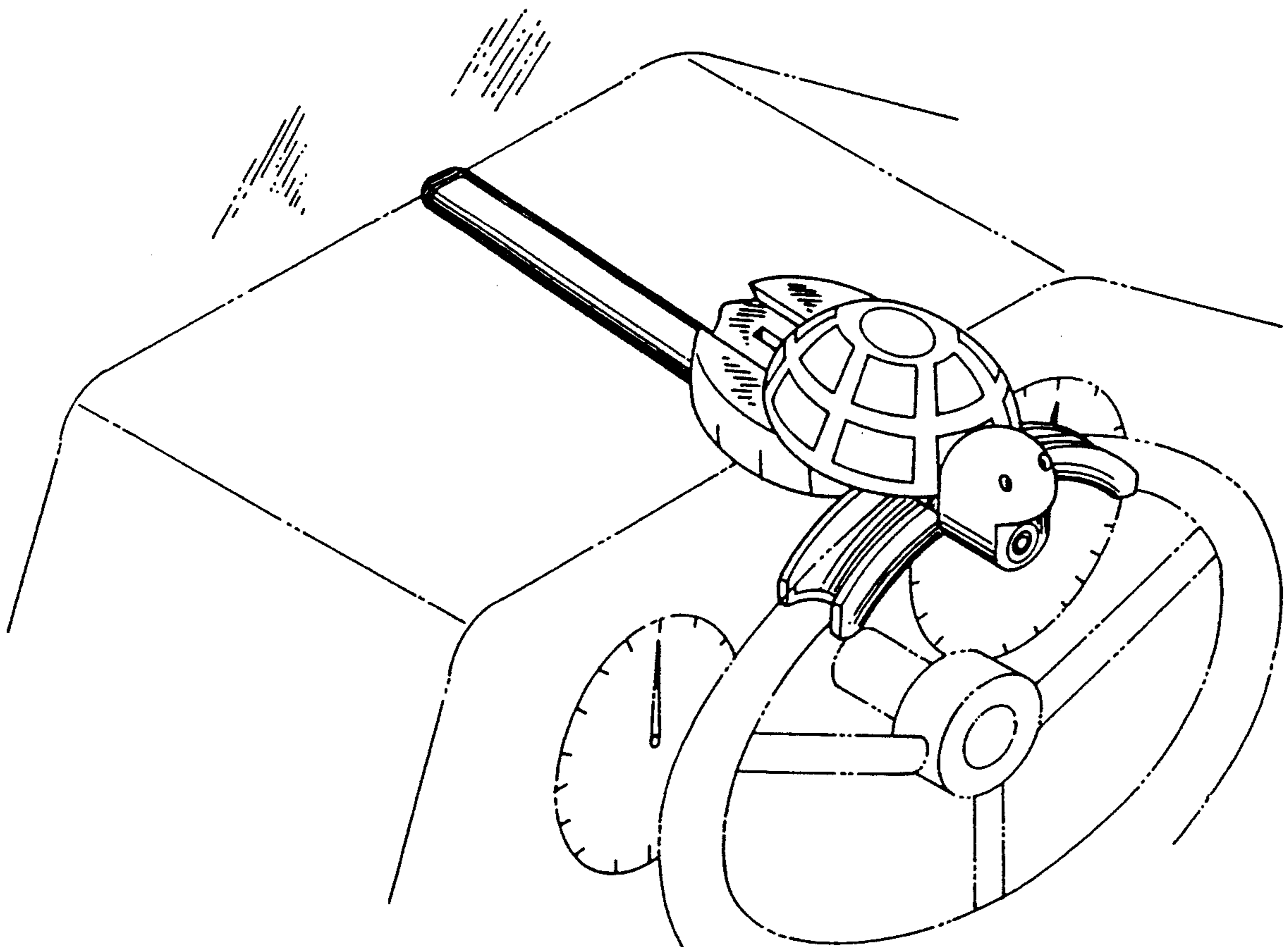

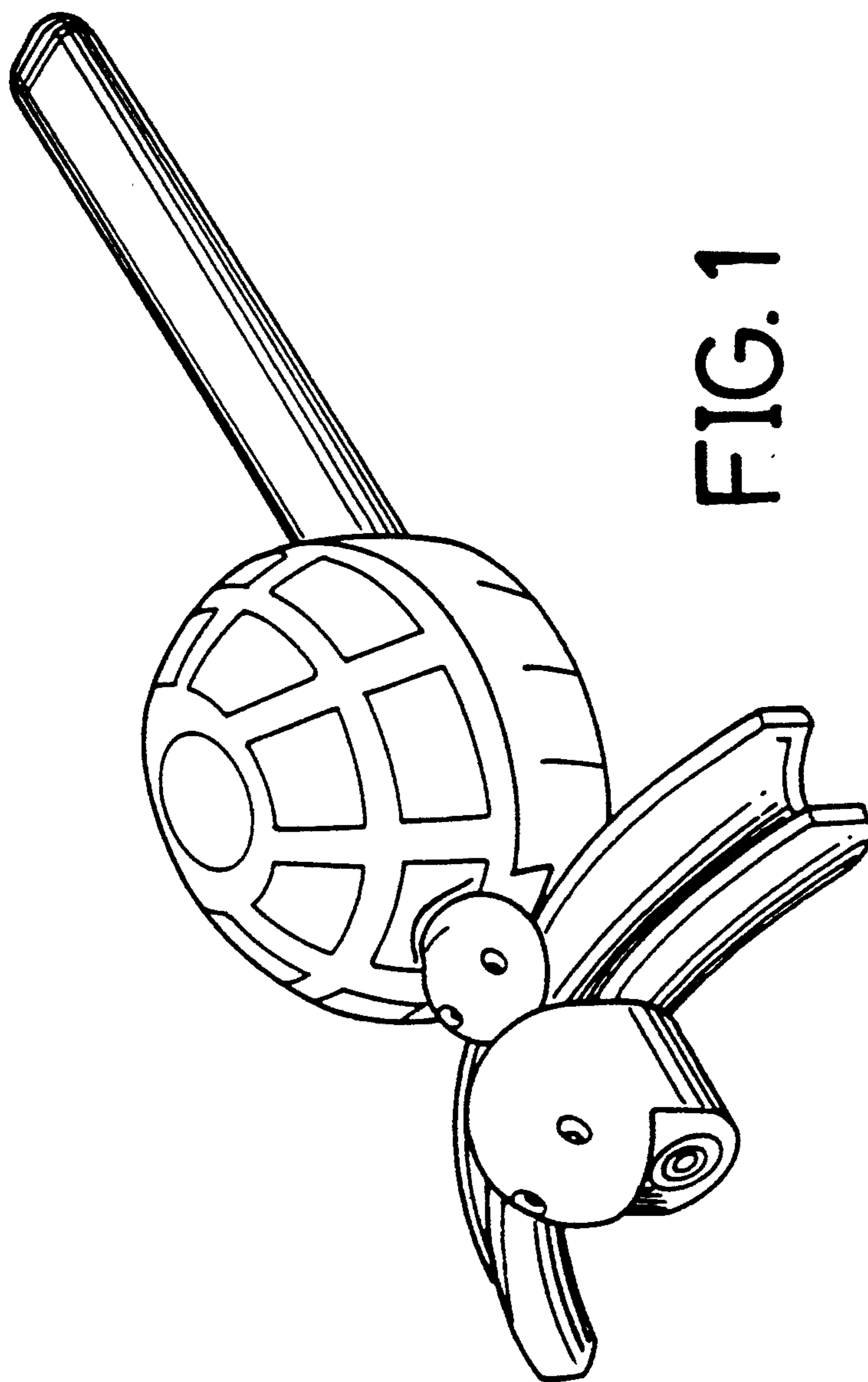

FIG. 1

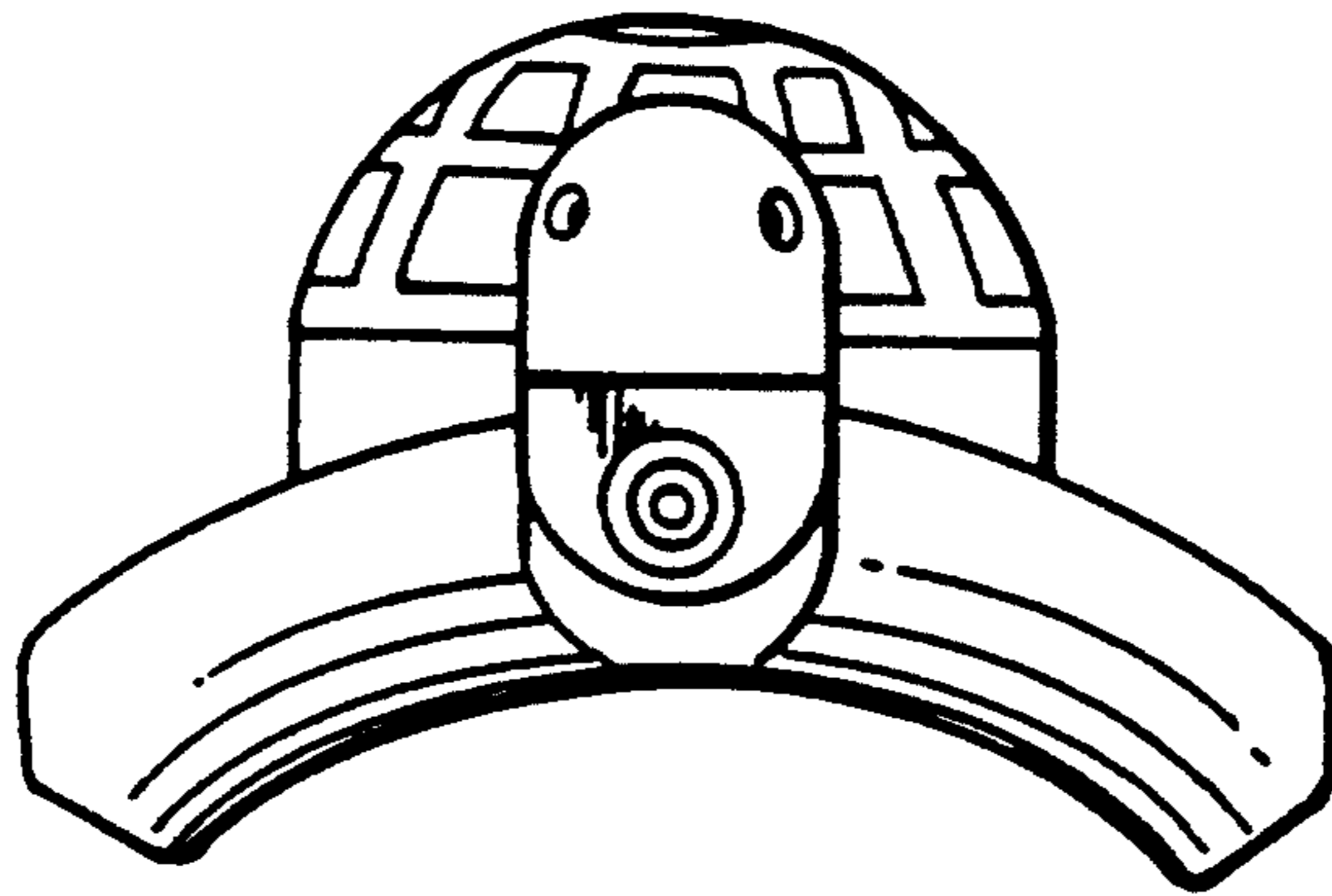

FIG. 2

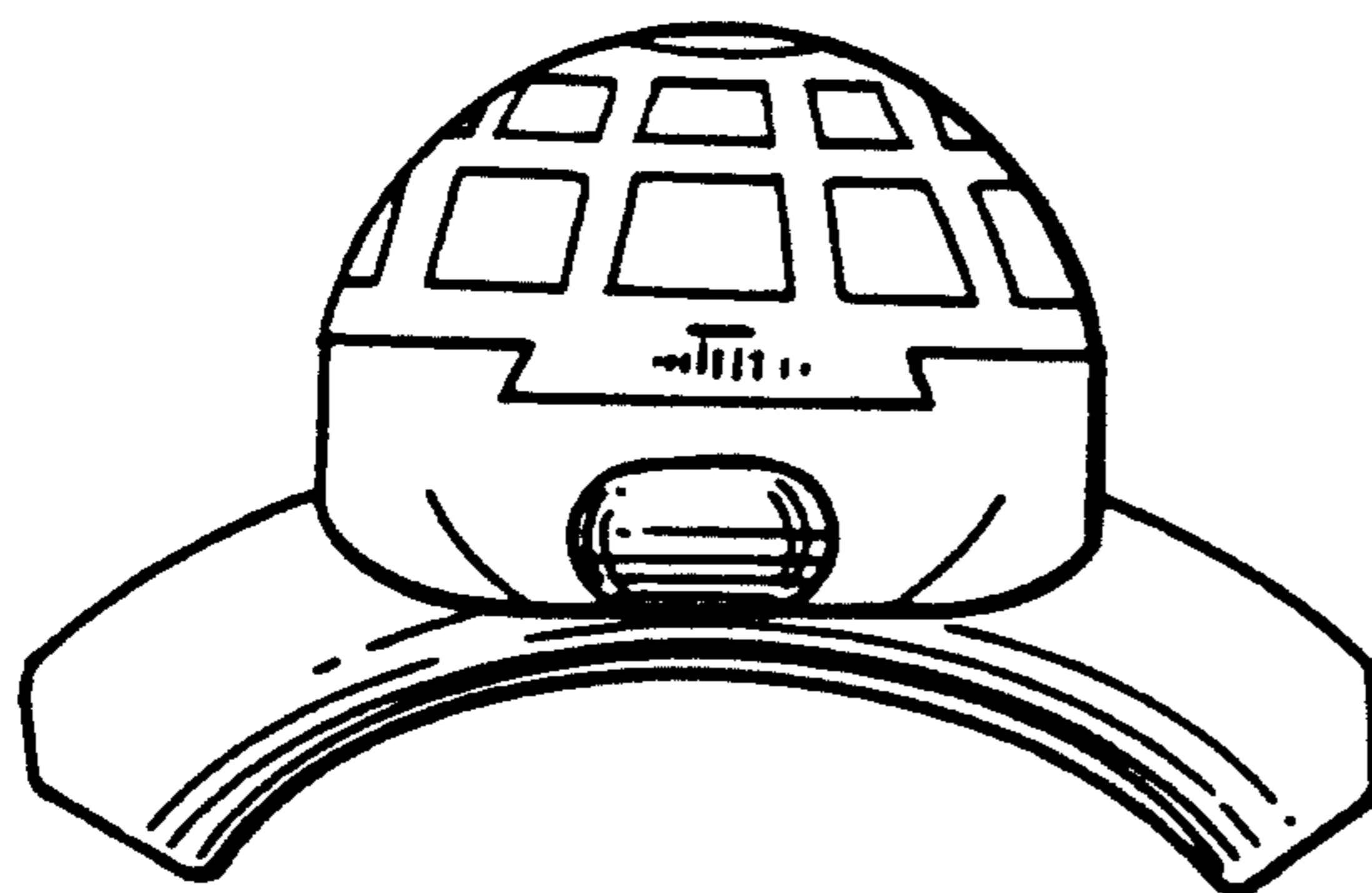

FIG. 3

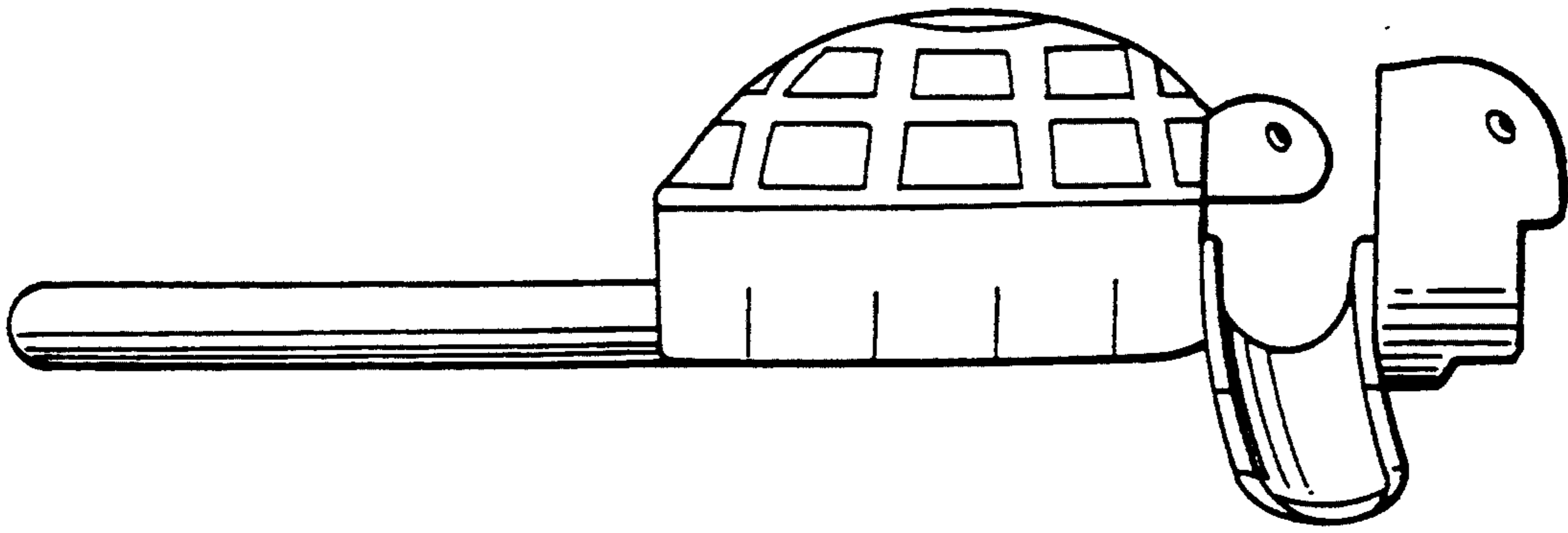

FIG. 4

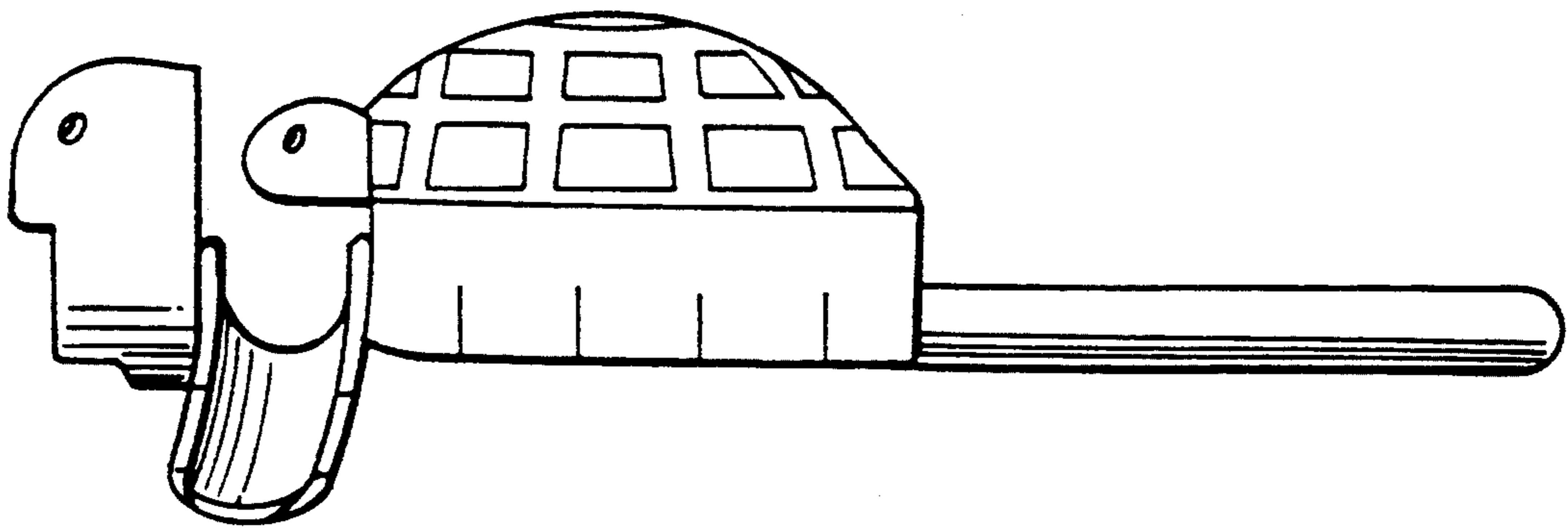

FIG. 5

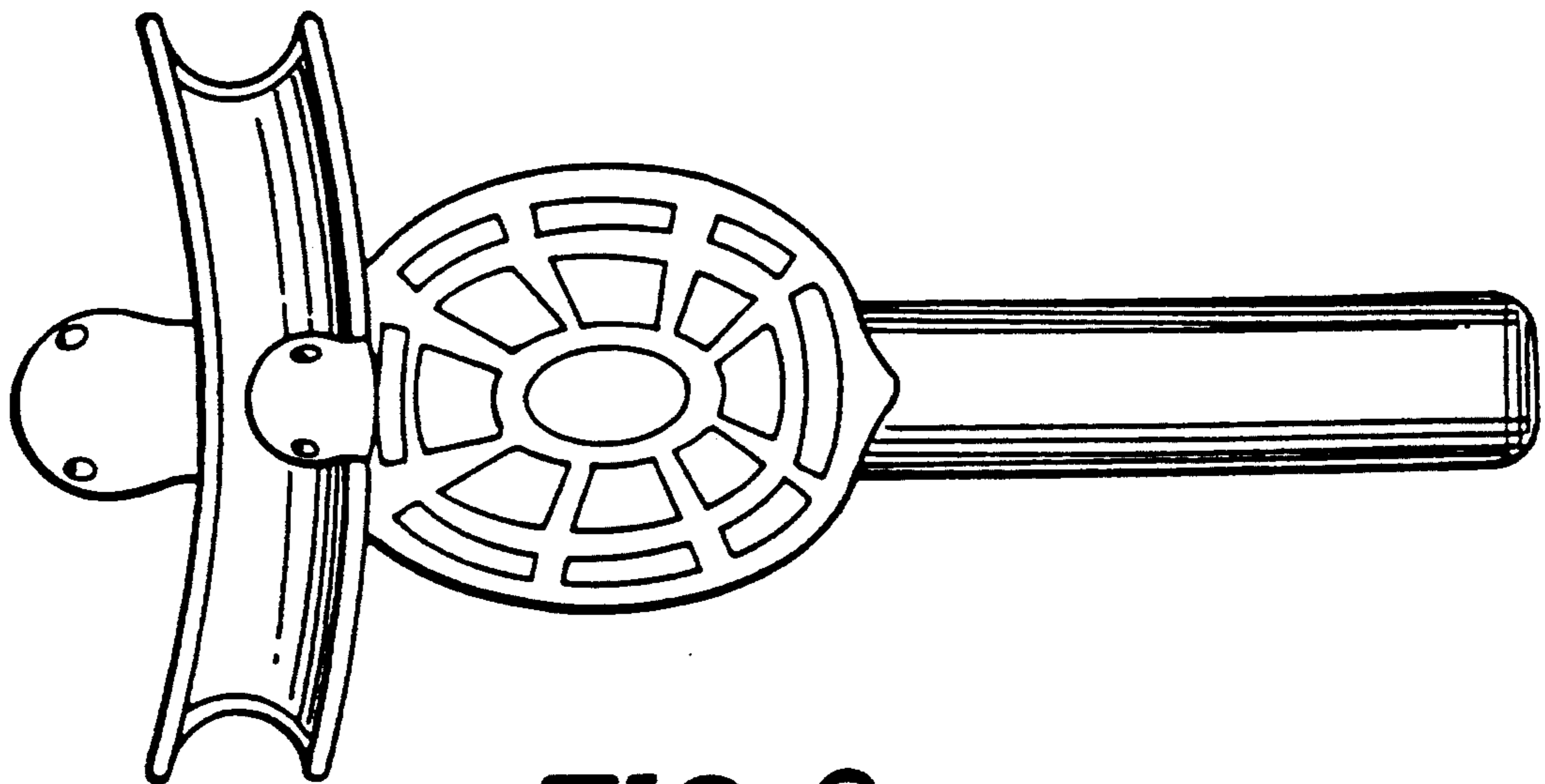

FIG. 6

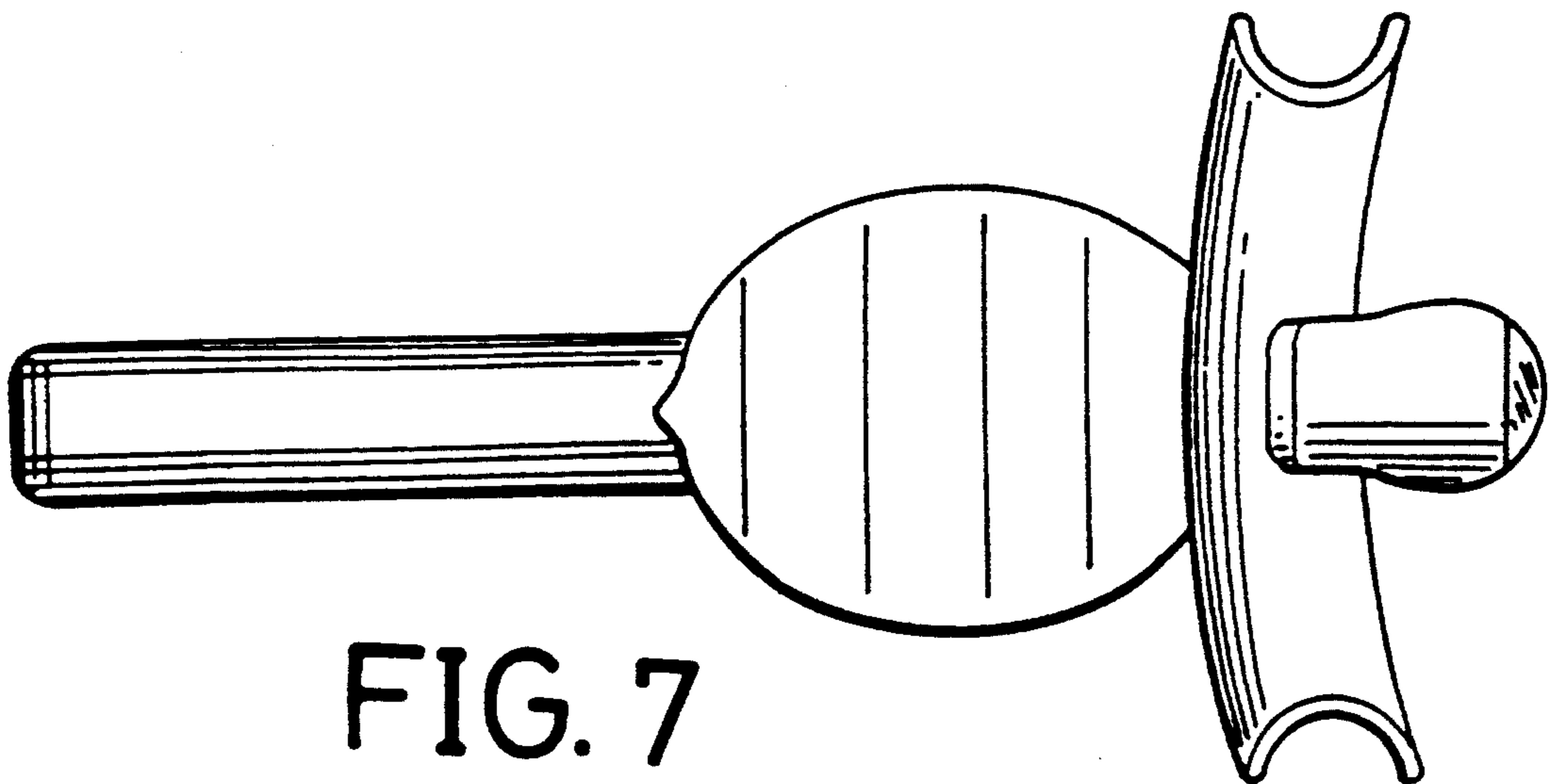

FIG. 7

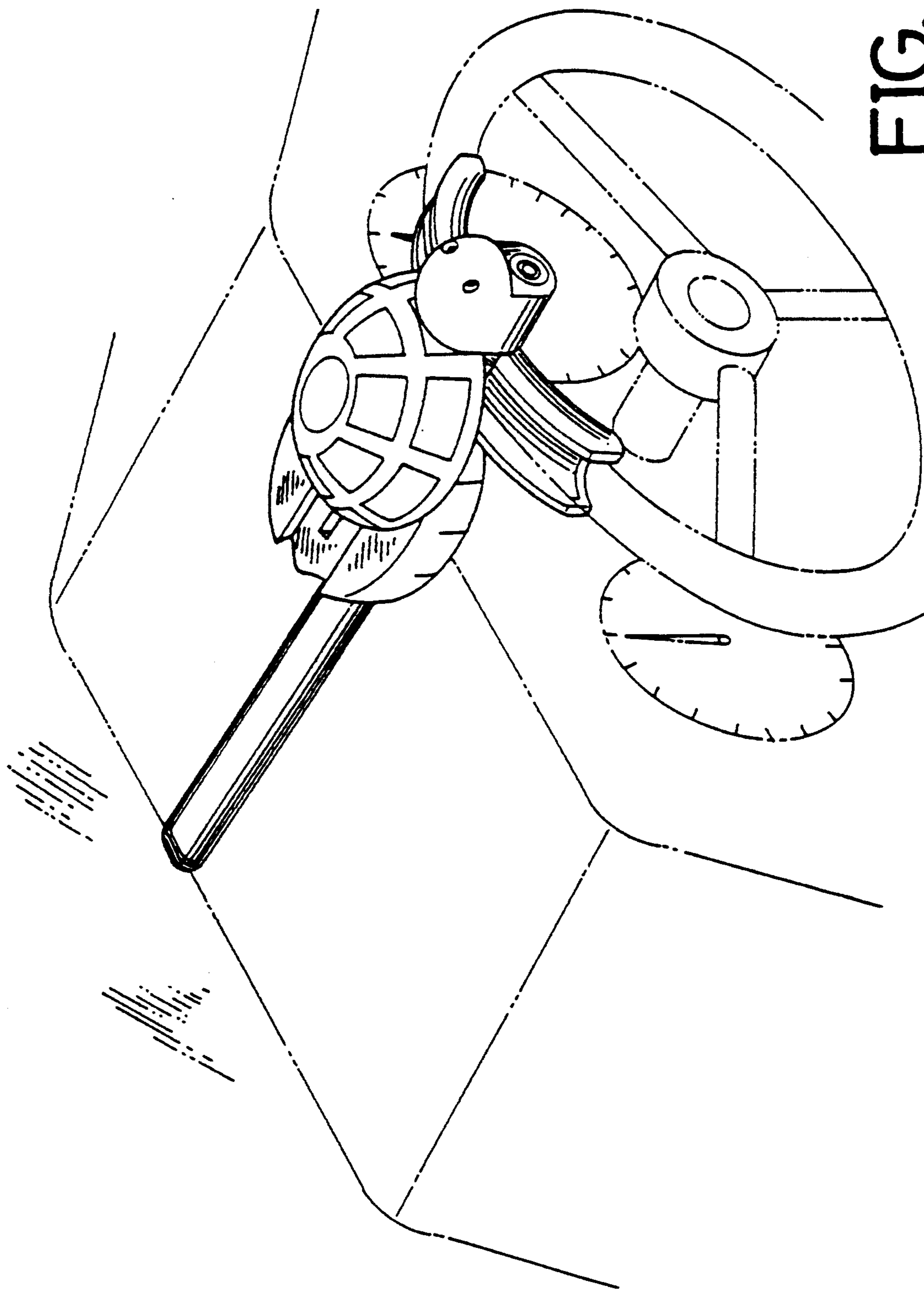

FIG. 8