



US00D348206S

United States Patent [19]

Chen

[11] Patent Number: **Des. 348,206**

[45] Date of Patent: **** Jun. 28, 1994**

- [54] **AUTOMOBILE STEERING LOCK**
- [76] Inventor: **Tian-Yuan Chen**, 95-4, Min-Hsiang Street, Chung-Ho, Taipei Hsien, Taiwan
- [**] Term: **14 Years**
- [21] Appl. No.: **9,687**
- [22] Filed: **Jun. 21, 1993**
- [52] U.S. Cl. **D8/231**
- [58] Field of Search **D8/330-331, D8/333, 339, 341; 70/14, 233-237, 238, 245, 247, 252**

- 4,974,433 12/1990 Wang 70/237 X
- 5,095,723 3/1992 Lin 70/209 X

FOREIGN PATENT DOCUMENTS

- 2413710 3/1974 Fed. Rep. of Germany 70/238
- 2238519A 6/1991 United Kingdom 70/238

Primary Examiner—Brian N. Vinson

[57] CLAIM

The ornamental design for an automobile steering lock, shown.

DESCRIPTION

FIG. 1 is a top, front, and right side perspective view of an automobile steering lock showing my new design; FIG. 2 is a front elevational view thereof; FIG. 3 is a rear elevational view thereof; FIG. 4 is a left elevational view thereof; FIG. 5 is a right side elevational view thereof; FIG. 6 is a top plan view thereof; and, FIG. 7 is a bottom plan view thereof.

- [56] **References Cited**
- U.S. PATENT DOCUMENTS**
- D. 330,500 10/1992 Chen D8/331
- D. 333,970 3/1993 Starmer D8/331
- D. 339,973 10/1993 Chen D8/331
- D. 340,855 11/1993 Wu et al. D8/331
- 4,882,920 11/1989 Wu 70/209

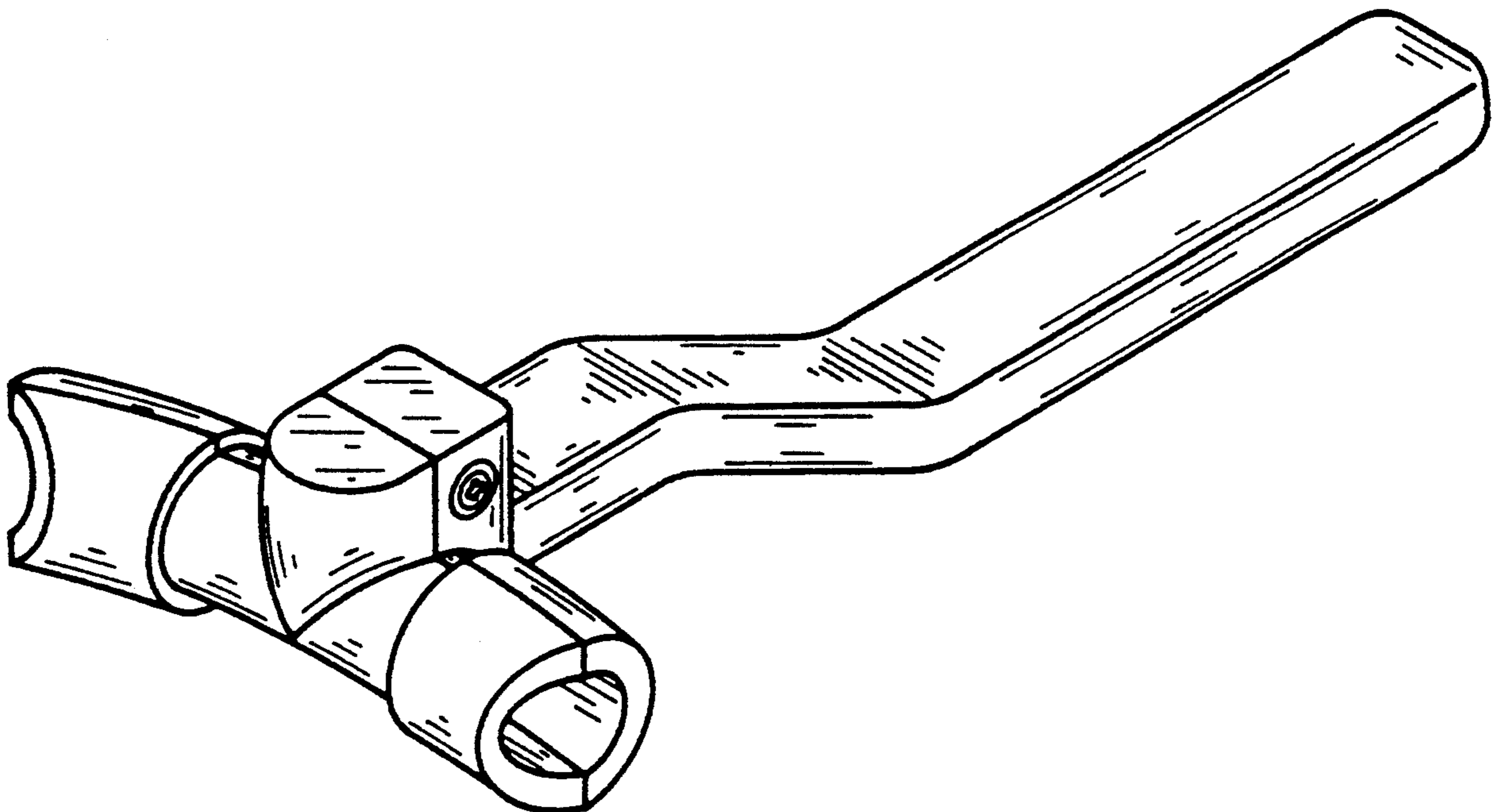

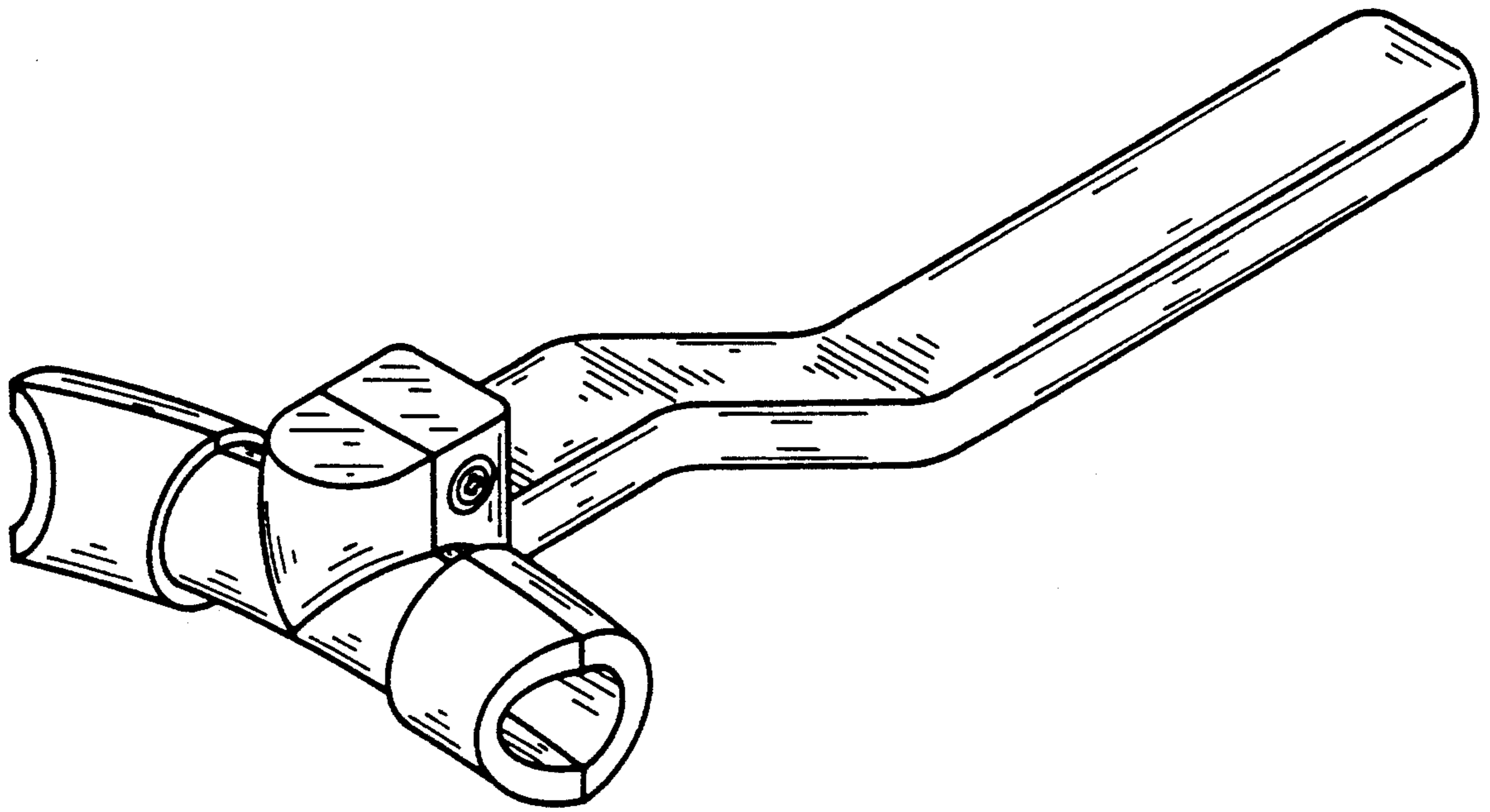

FIG. 1

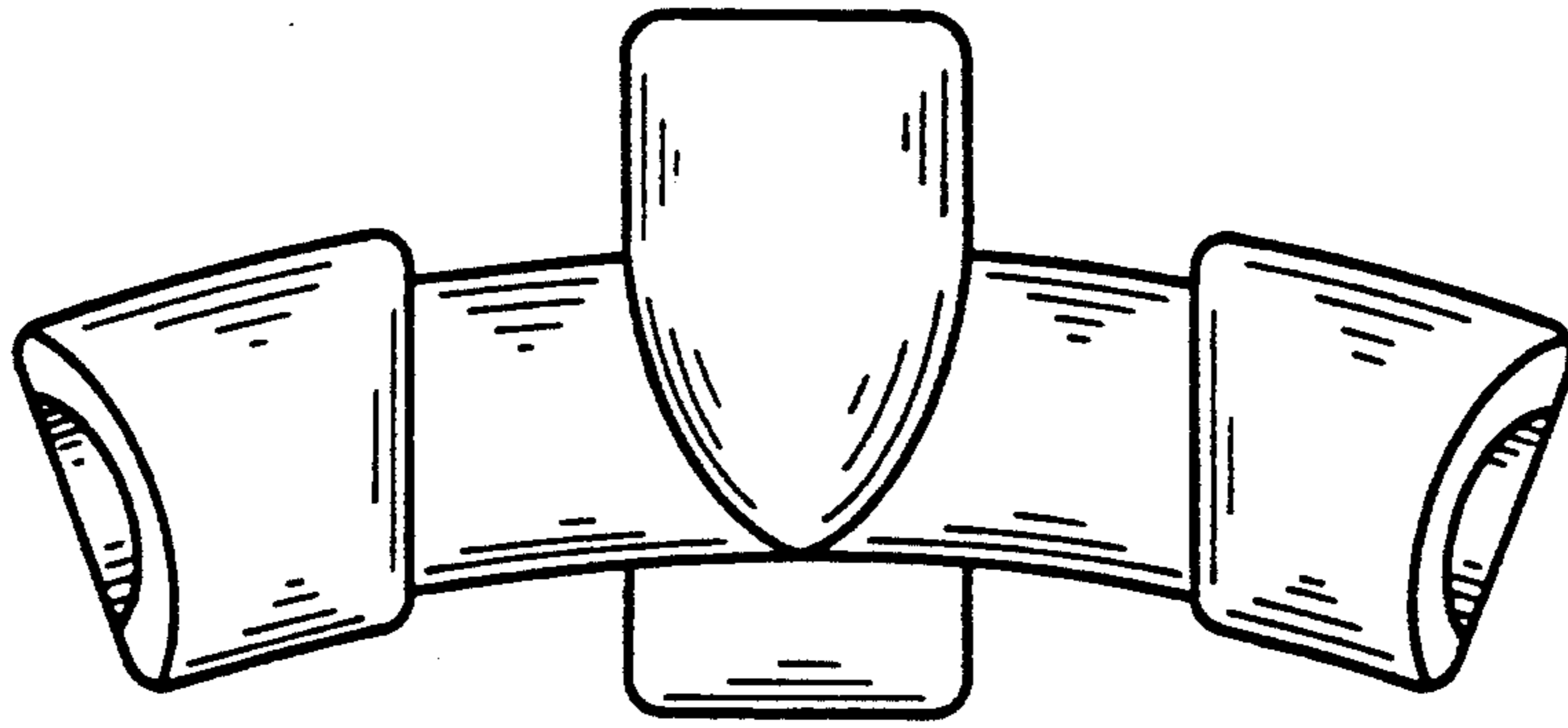

FIG. 2

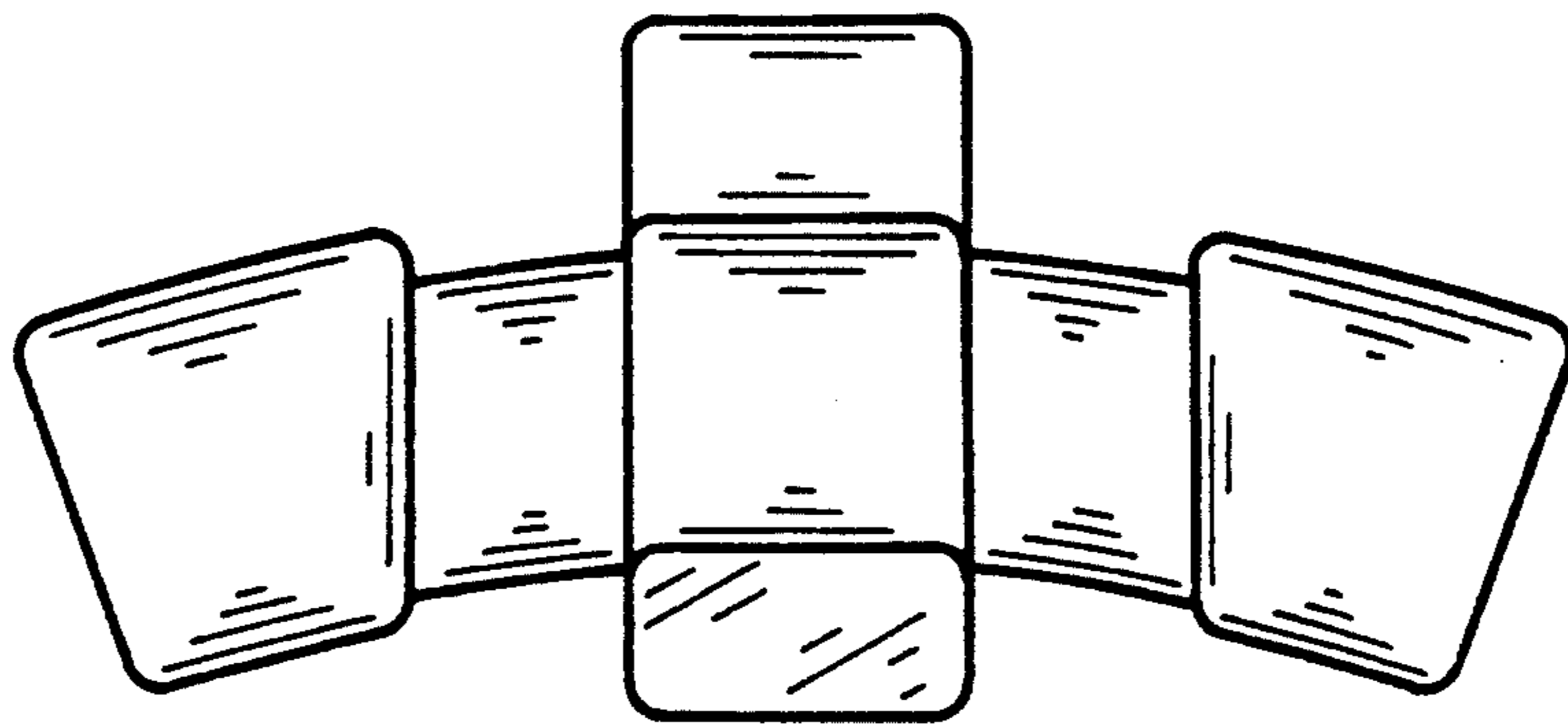

FIG. 3

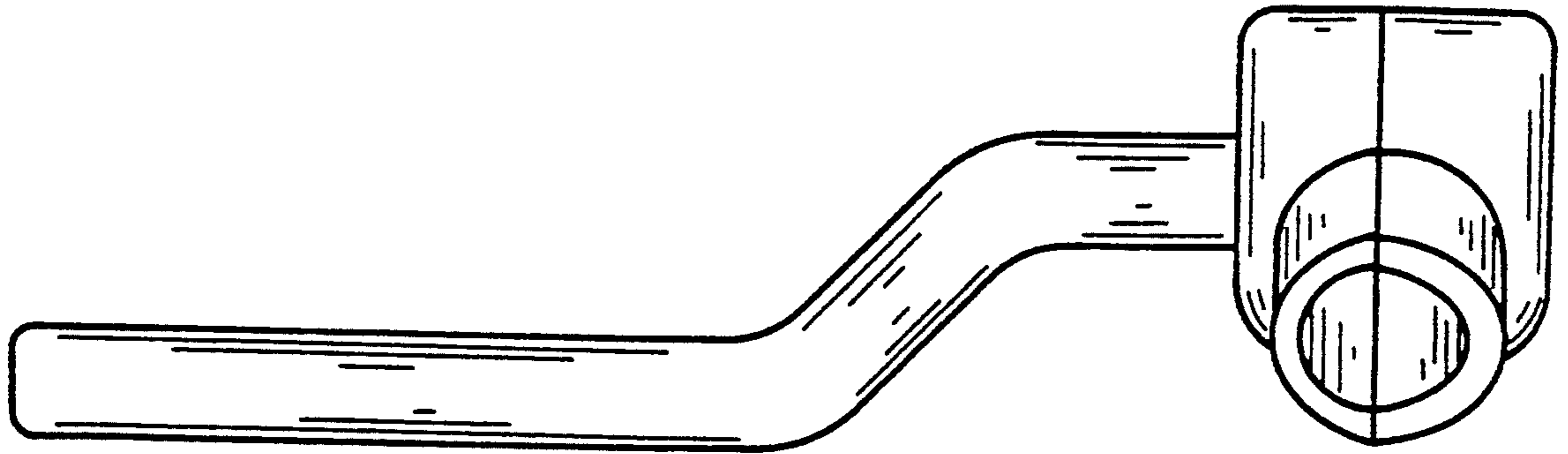

FIG. 4

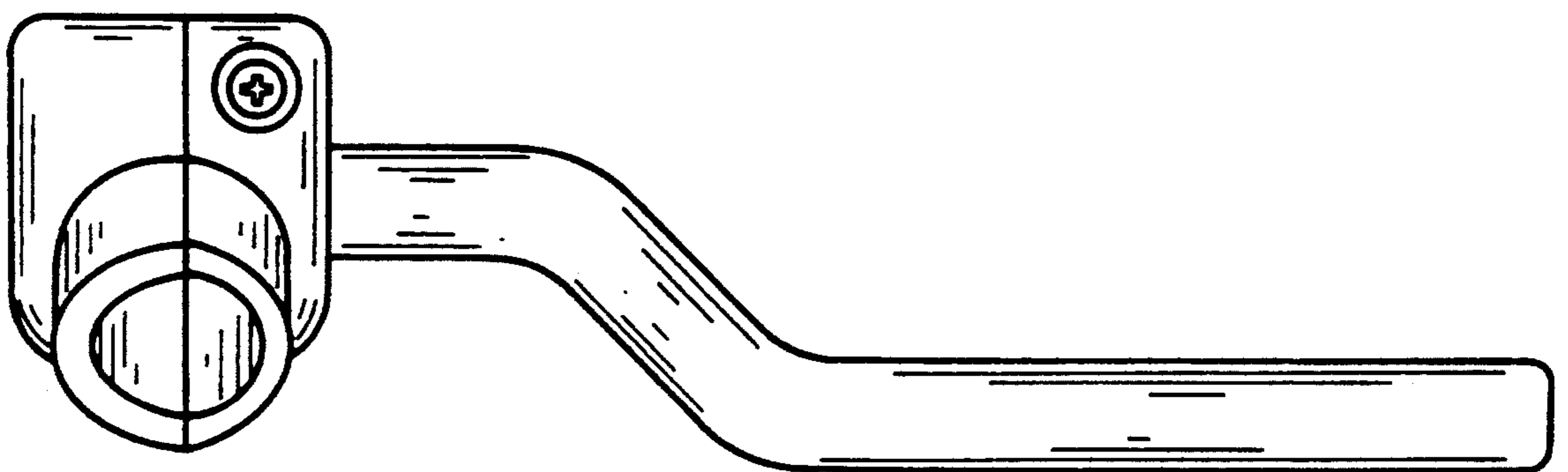

FIG. 5

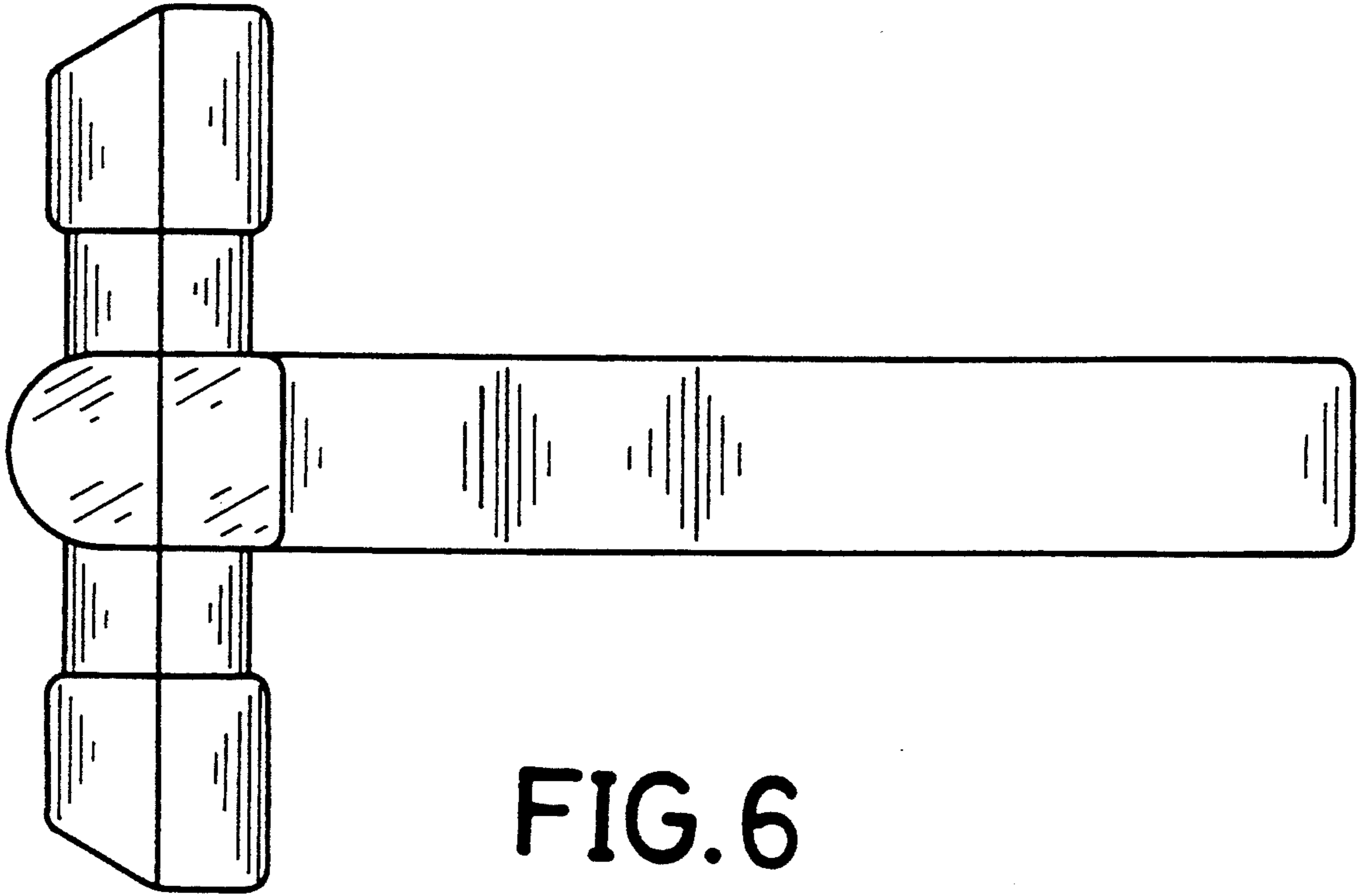

FIG. 6

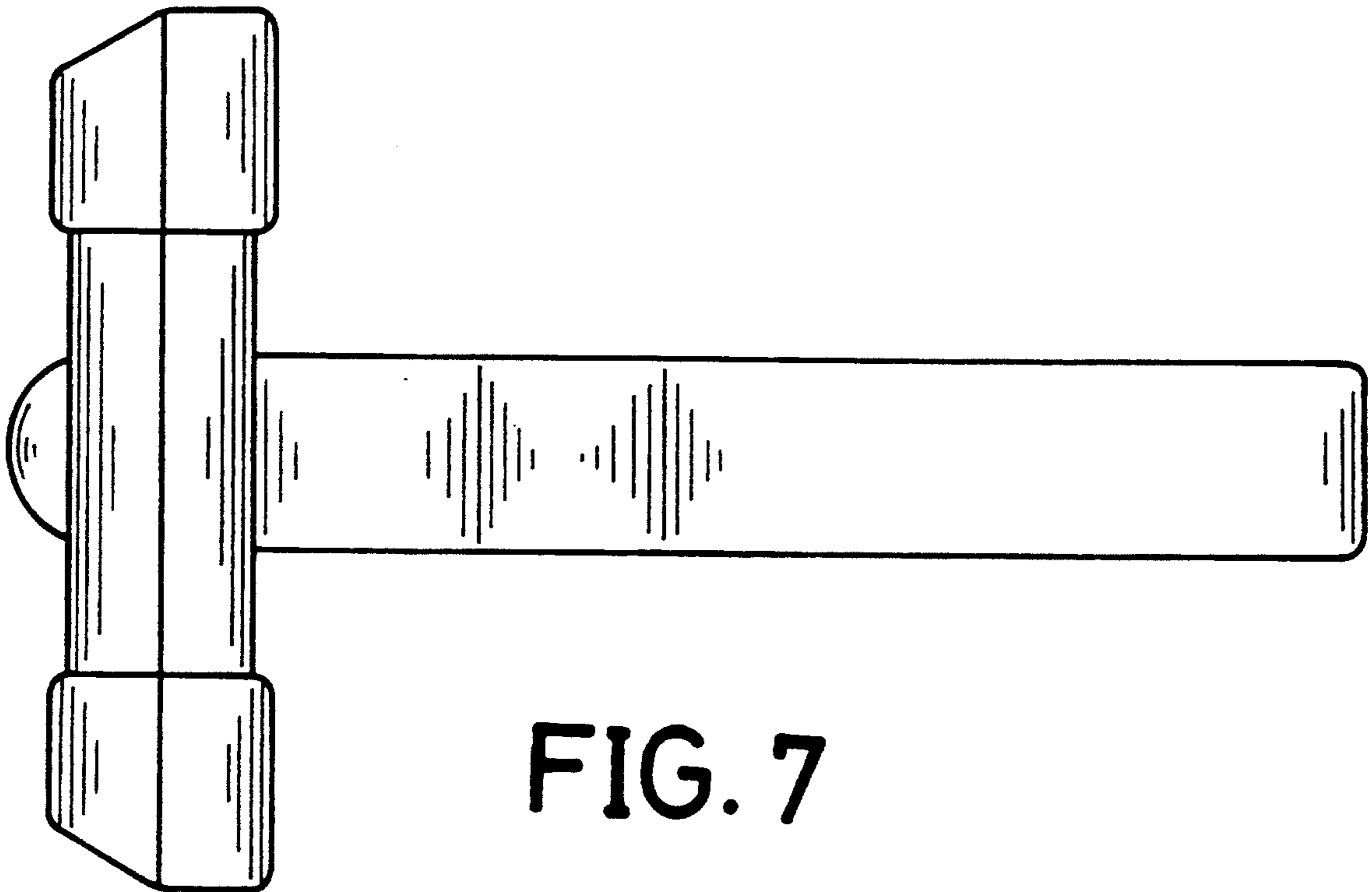

FIG. 7