



US00D348196S

United States Patent [19]
Forsberg

[11] **Patent Number: Des. 348,196**
[45] **Date of Patent: ** Jun. 28, 1994**

[54] **HOLDING DEVICE FOR TOOLS,
INSTRUMENTS AND PIPES**
[76] Inventor: **Bengt Forsberg, Fänestad, 330 12
Forsheda, Sweden**
[**] Term: **14 Years**
[21] Appl. No.: **814,911**
[22] Filed: **Dec. 23, 1991**

4,716,811 1/1988 Johnson 269/237

Primary Examiner—Alan P. Douglas
Assistant Examiner—J. H. Musgrove

[57] **CLAIM**

The ornamental design for a holding device for tools, instruments and pipes, as shown and described.

DESCRIPTION

FIG. 1 is a top, front and right-side perspective view of a holding device for tools, instruments and pipes showing my new design;

FIG. 2 is a bottom, rear and left-side perspective view thereof;

FIG. 3 is a top, front and right-side perspective view with the clamping jaws in an open position;

FIG. 4 is a rear, bottom and left-side perspective view with the jaws in an open position;

FIG. 5 is a top, front and right-side perspective view with the barrel clamp in an alternating position; and,

FIG. 6 is a bottom, rear and left-side perspective view thereof.

[30] **Foreign Application Priority Data**
Jun. 24, 1991 [SE] Sweden 91-1307
[52] U.S. Cl. **D8/72**
[58] **Field of Search** **D8/72, 73, 373;**
248/74.1, 62, 74.4, 65, 58, 55, 228, 300;
269/268, 238, 239, 237

[56] **References Cited**
U.S. PATENT DOCUMENTS

D. 313,490 1/1991 Abbey D8/373
4,524,959 6/1985 Kubo 269/239

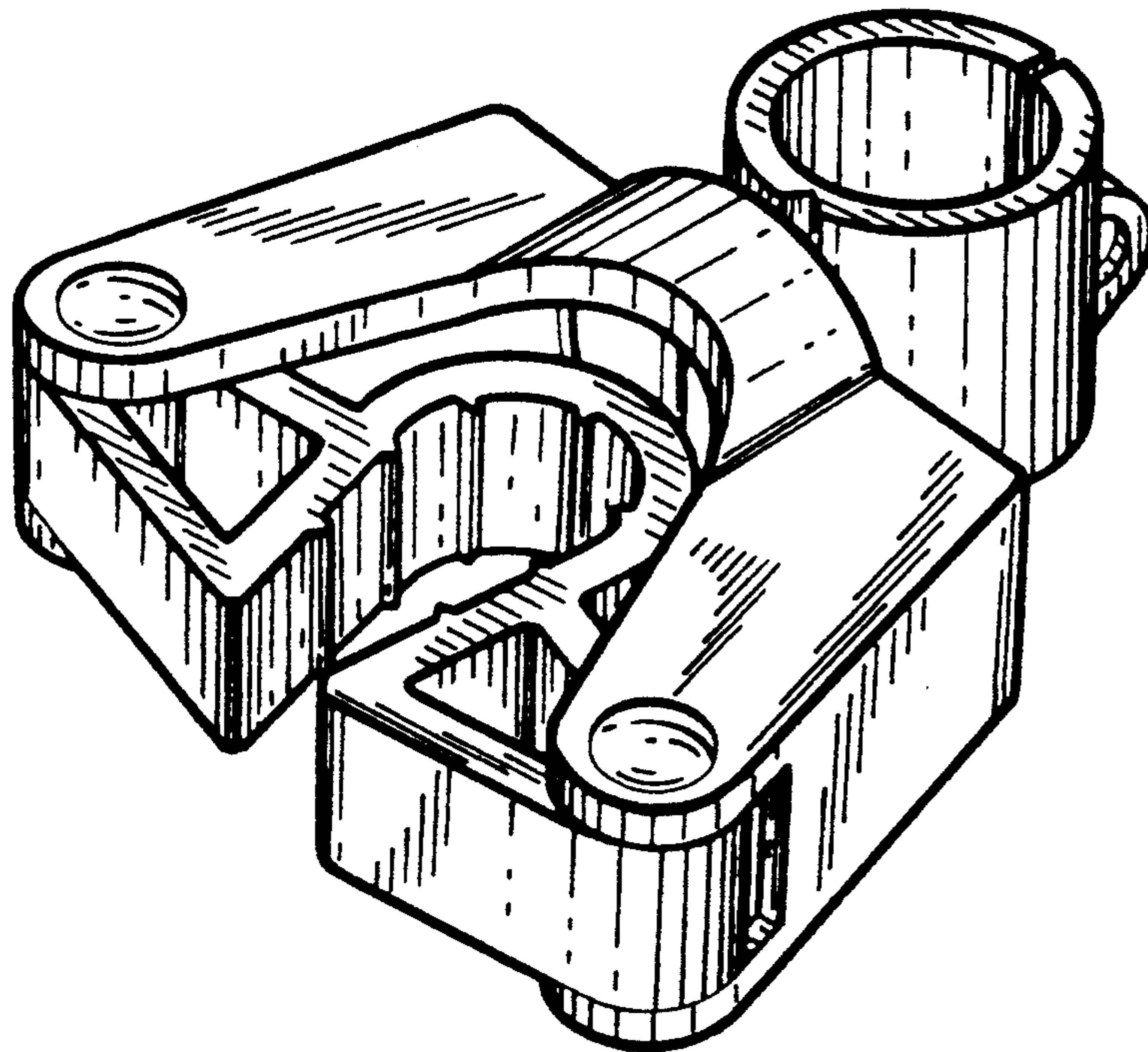

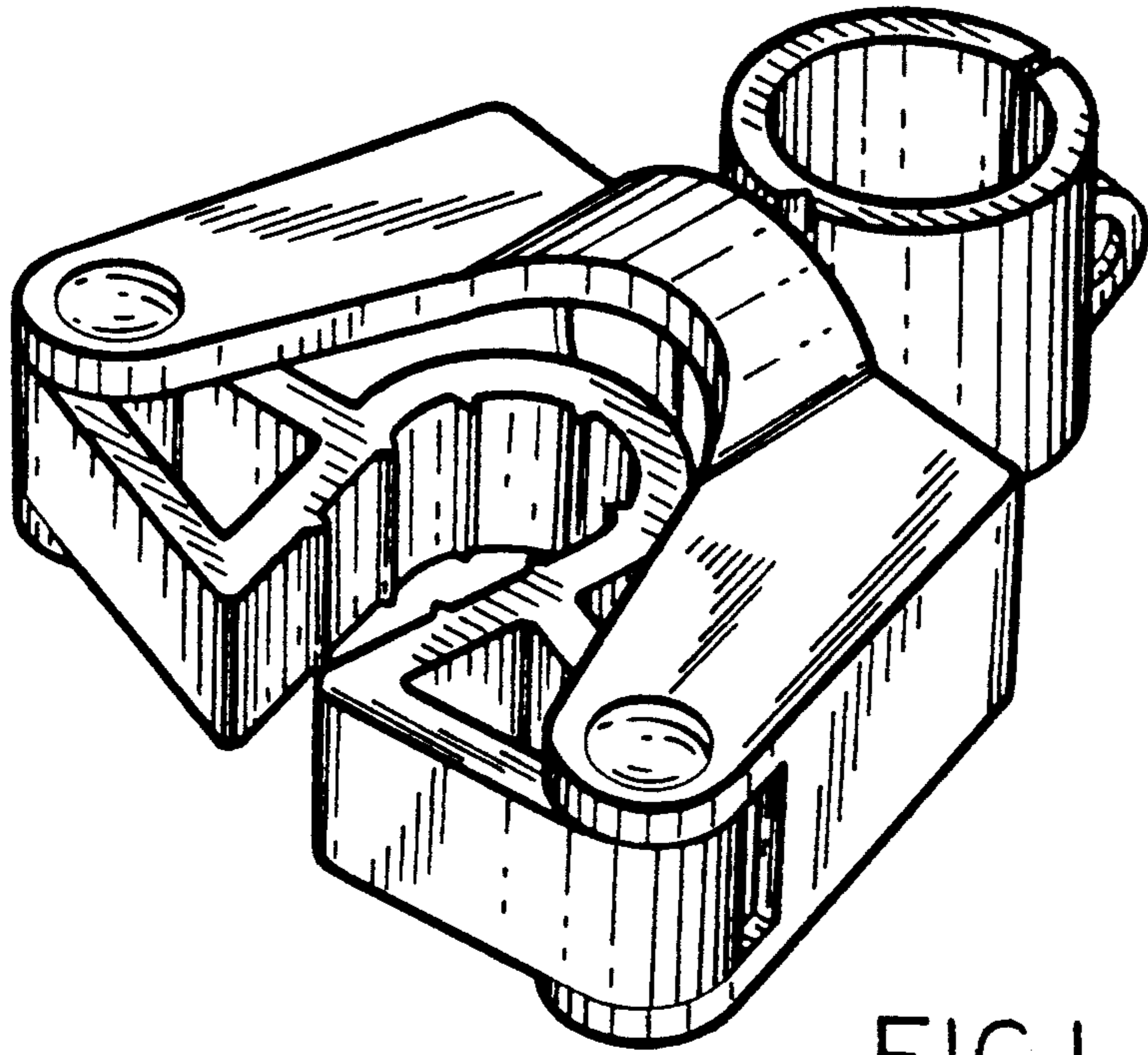

FIG. 1

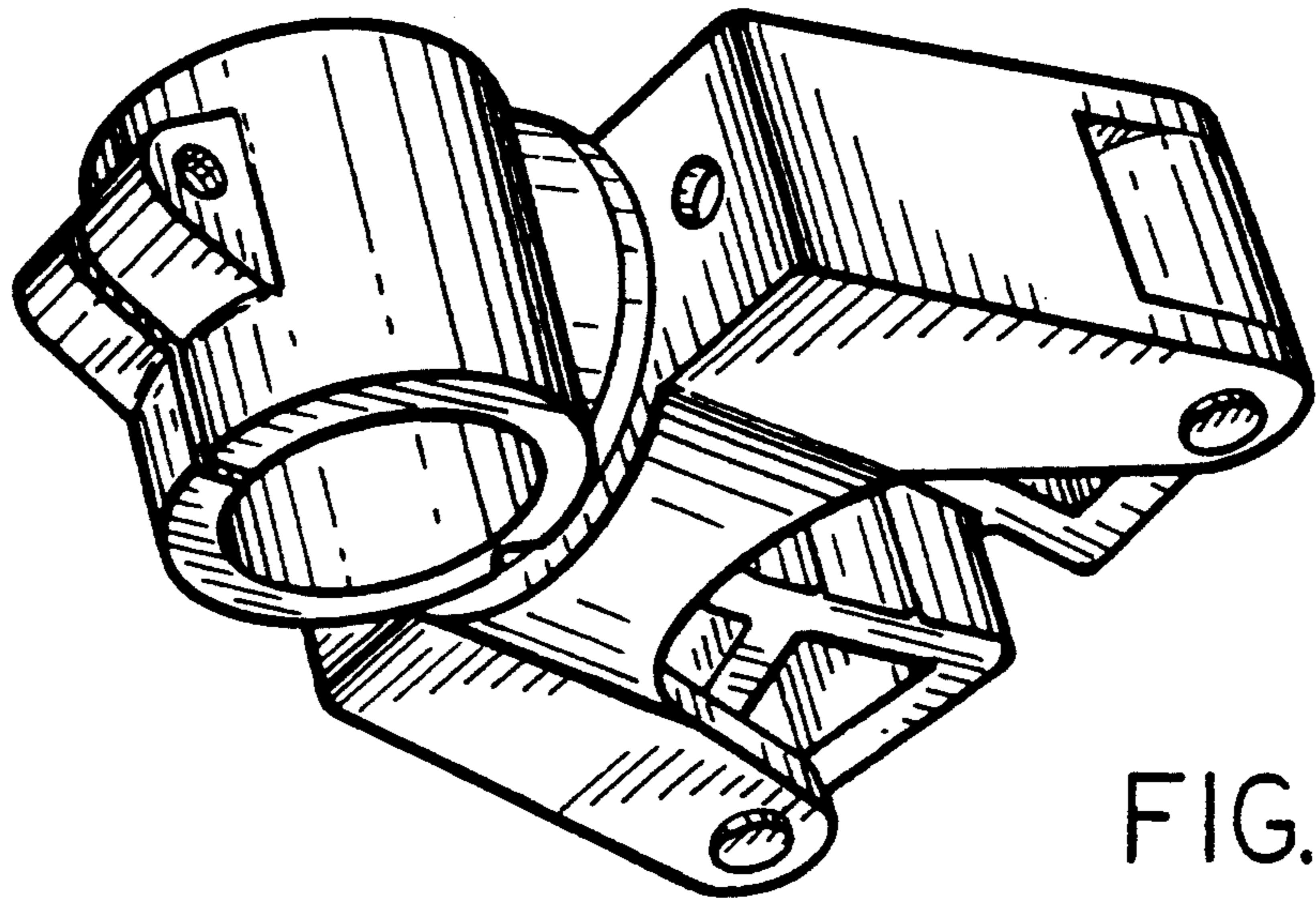

FIG. 2

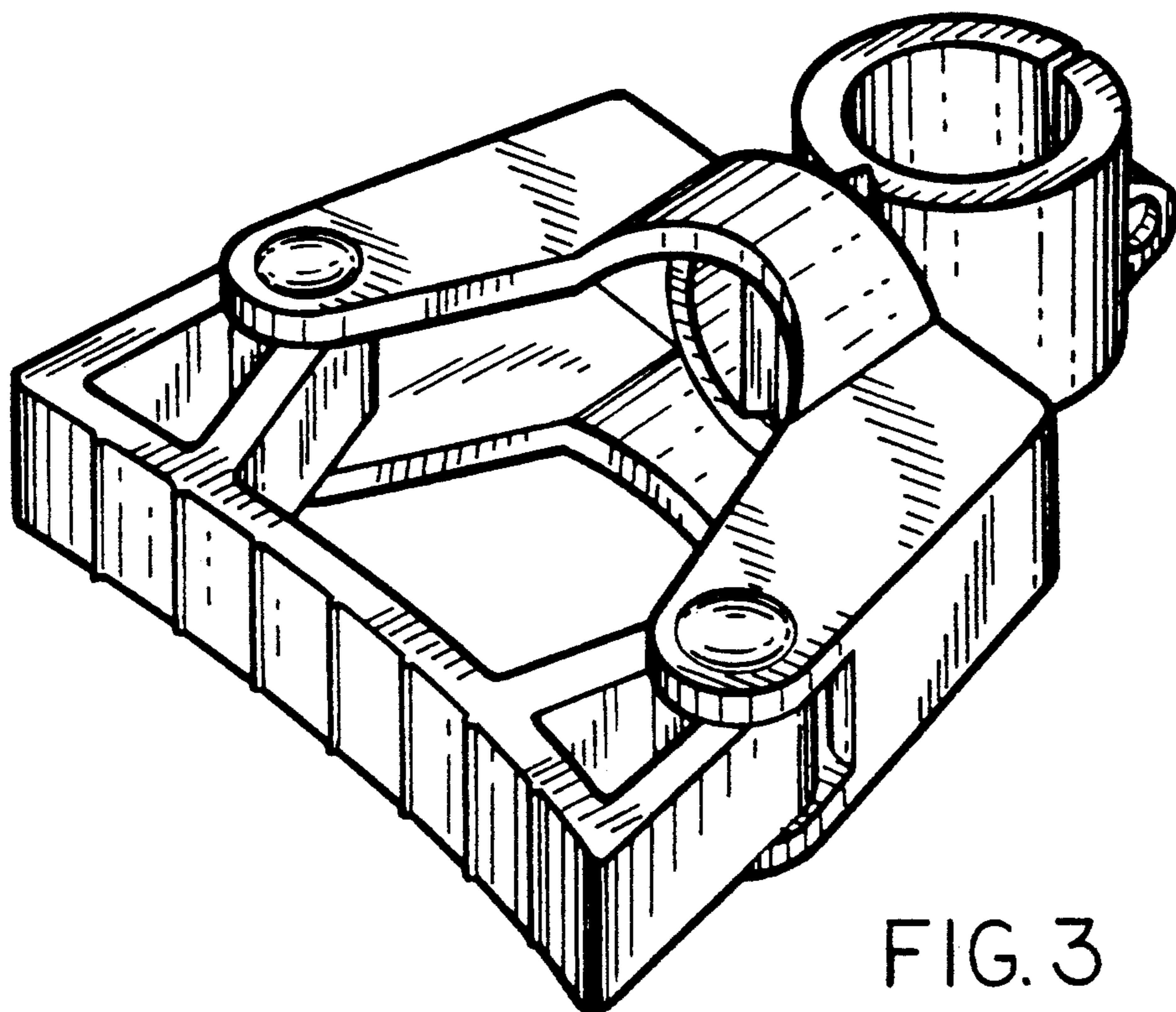

FIG. 3

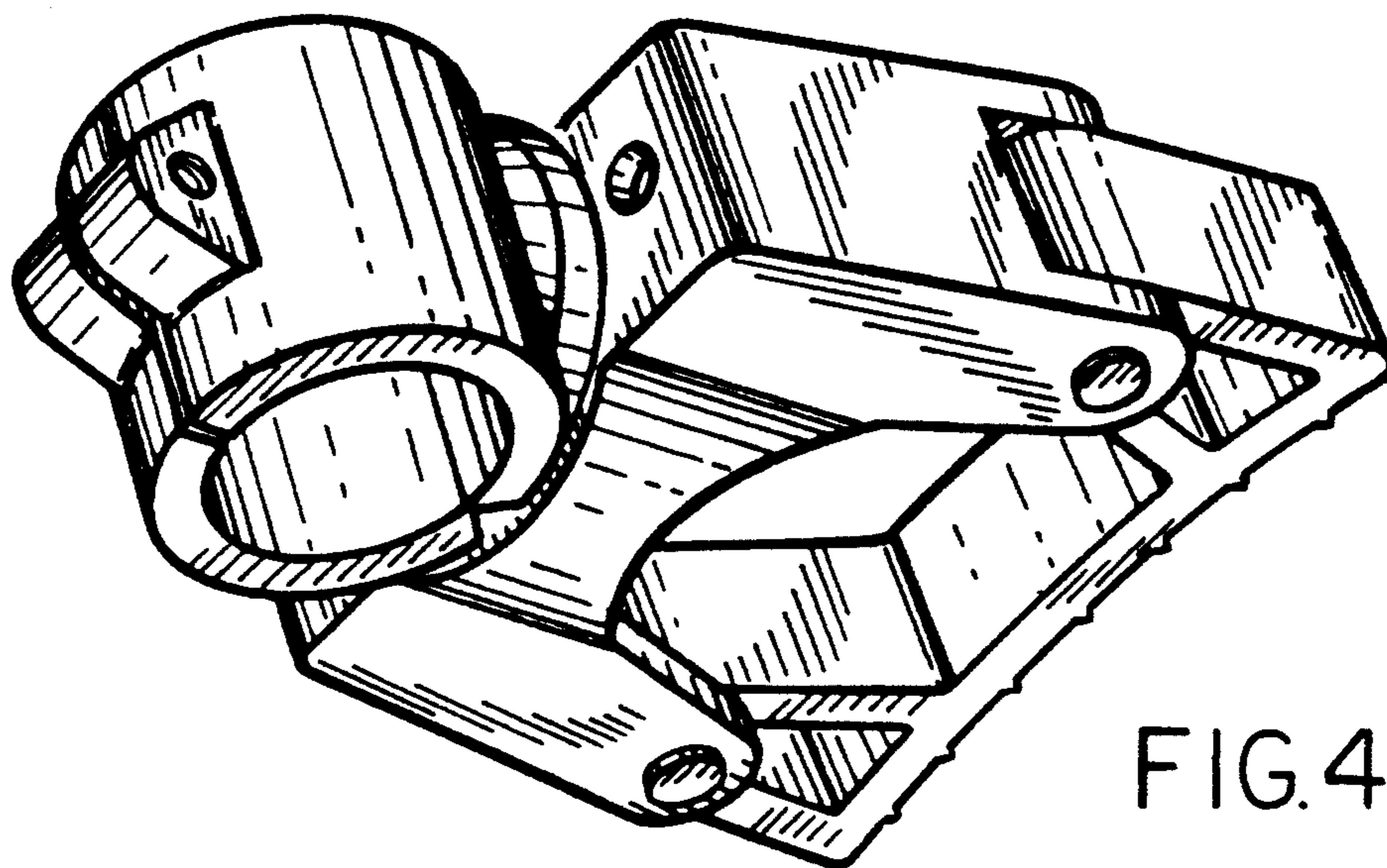

FIG. 4

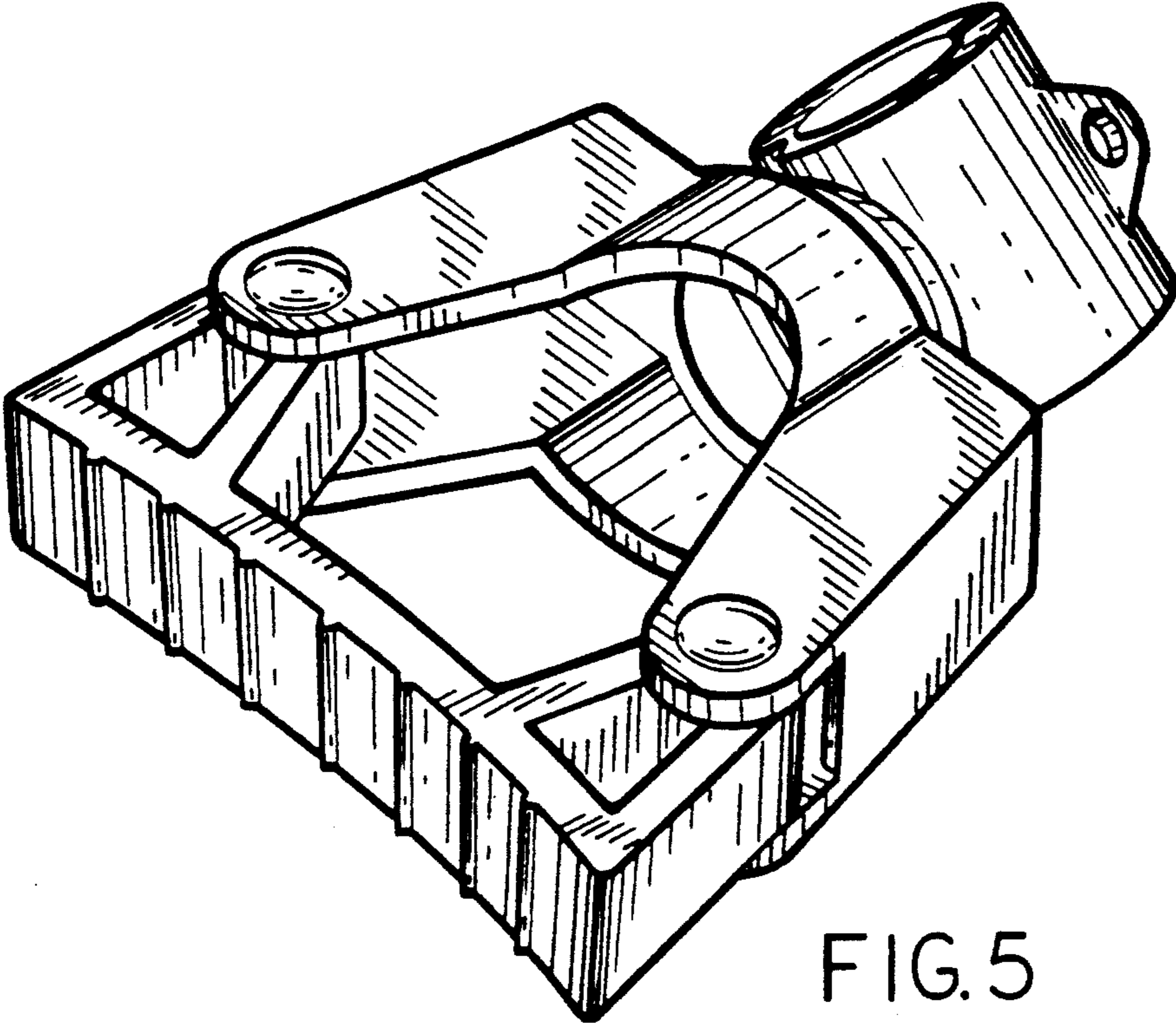

FIG. 5

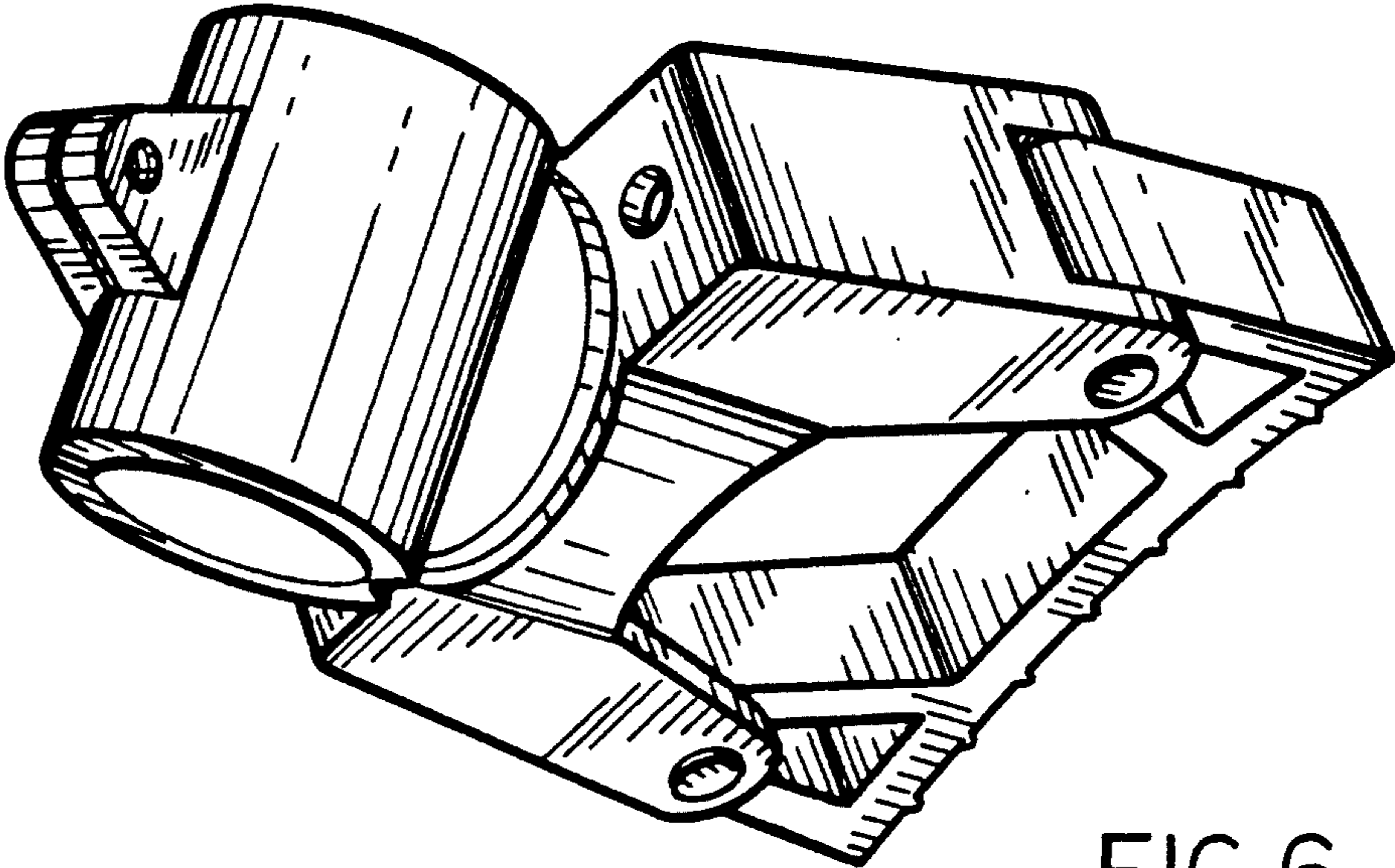

FIG. 6