



US00D348046S

United States Patent [19]

[11] Patent Number: **Des. 348,046**

Hulsebus

[45] Date of Patent: **** Jun. 21, 1994**

[54] **BATTERY ADAPTER TO PROVIDE PROPER FIX INTO BATTERY TRAY**

FOREIGN PATENT DOCUMENTS

[75] Inventor: **Randy K. Hulsebus, Colgate, Wis.**

600011 4/1960 Canada 429/100

[73] Assignee: **Globe-Union Inc., Milwaukee, Wis.**

Primary Examiner—Wallace R. Burke

Assistant Examiner—Joel Sincavage

[**] Term: **14 Years**

Attorney, Agent, or Firm—Edward L. Levine; Joseph E. Root, III

[21] Appl. No.: **889,109**

[57] CLAIM

[22] Filed: **May 27, 1992**

The ornamental design for a battery adapter to provide proper fit into battery tray, as shown and described.

[52] U.S. Cl. **D13/119**

[58] Field of Search 180/68.5; 429/98, 99, 429/100; D13/119

DESCRIPTION

[56] References Cited

U.S. PATENT DOCUMENTS

- D. 269,868 7/1983 Seltzer et al. D13/119
- D. 311,898 11/1990 Luzader et al. D13/119
- D. 321,856 11/1991 Whitley et al. D13/119
- 4,508,794 4/1985 Wright 429/100

FIG. 1 is a perspective view of the battery adapter to provide proper fit into battery tray;
 FIG. 2 is a top plan view thereof;
 FIG. 3 is a bottom plan thereof;
 FIG. 4 is a front elevation view thereof, the rear elevation view being a mirror image; and,
 FIG. 5 is a right side elevation view thereof, the opposite side being a mirror image.

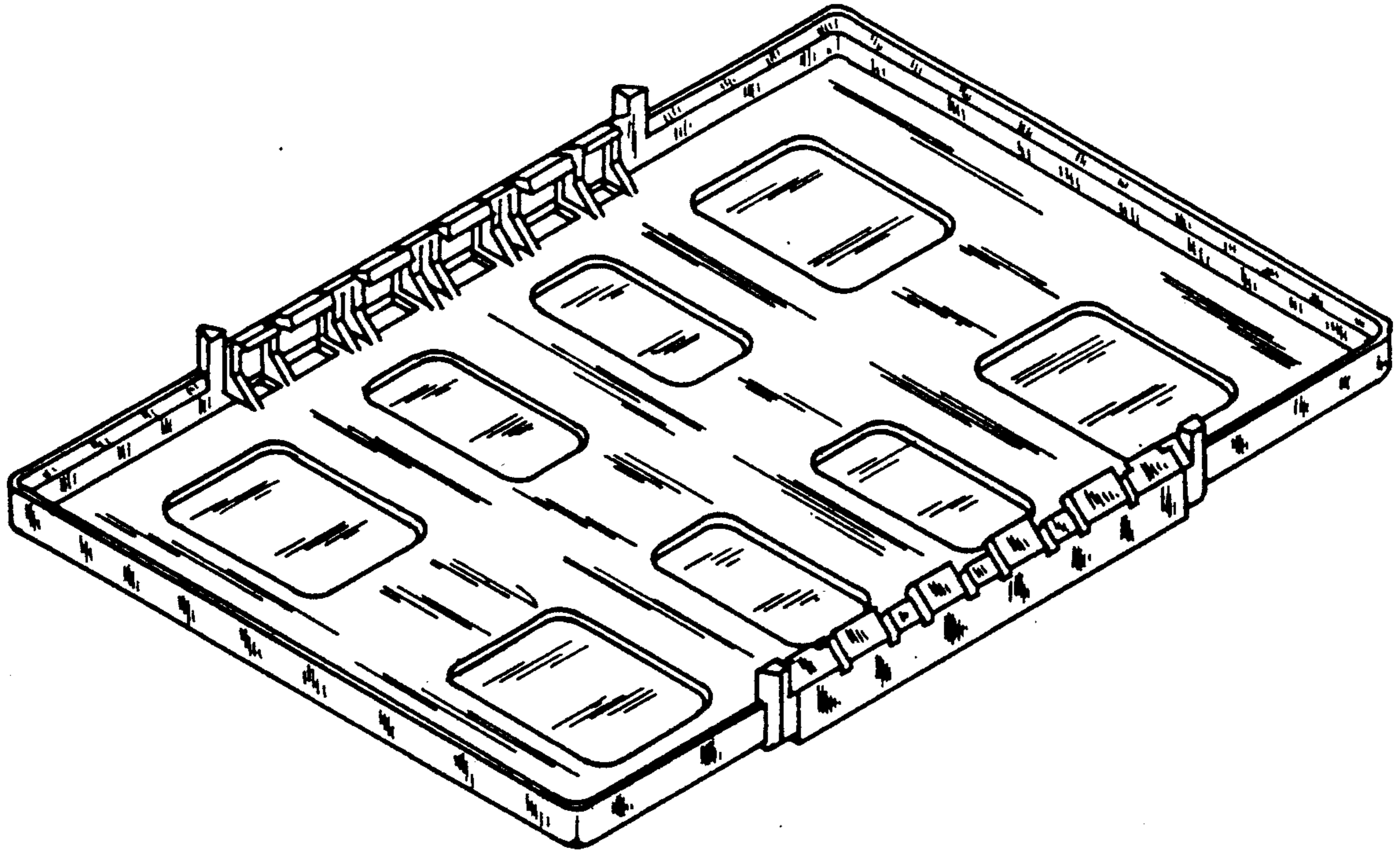

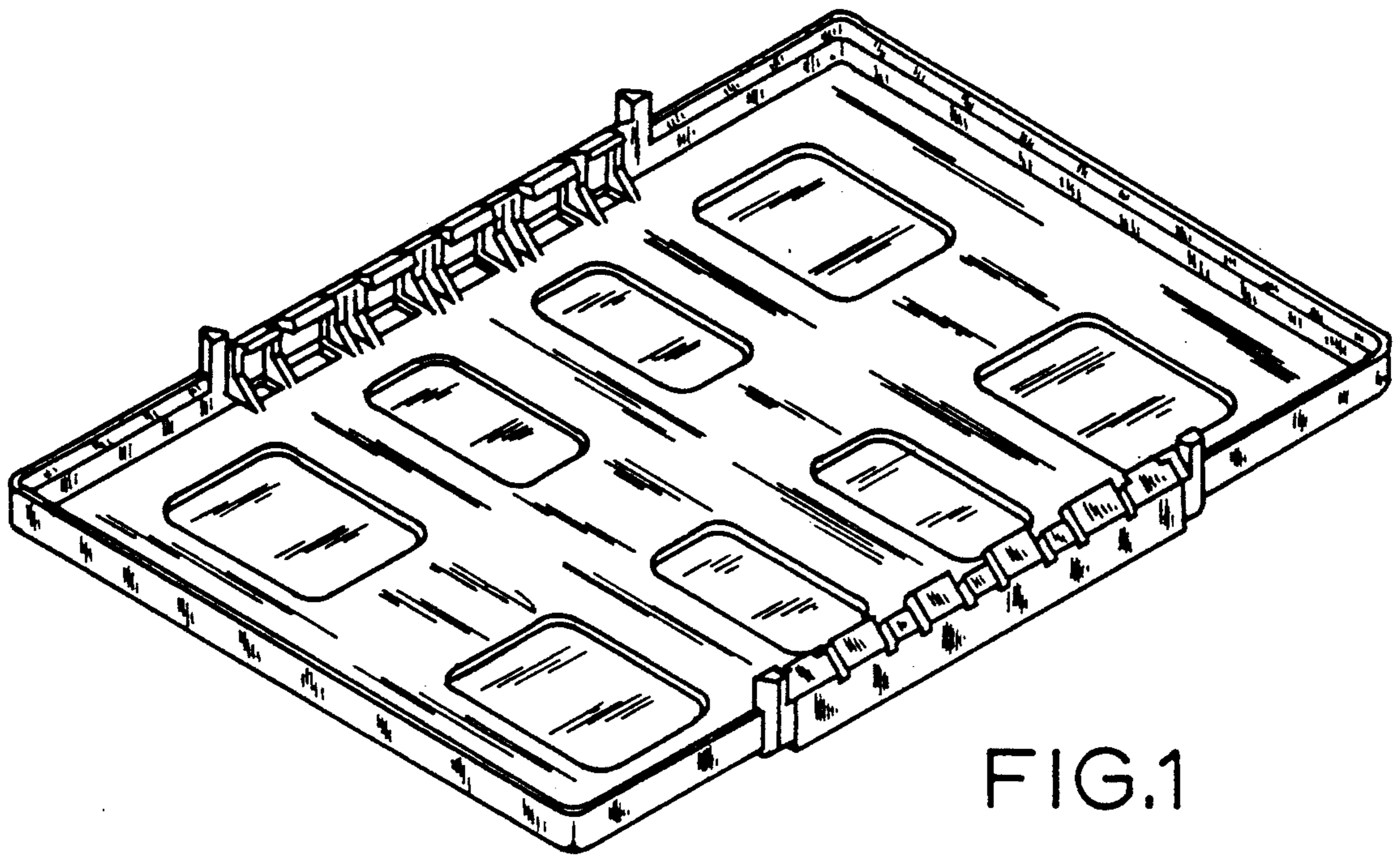

FIG. 1

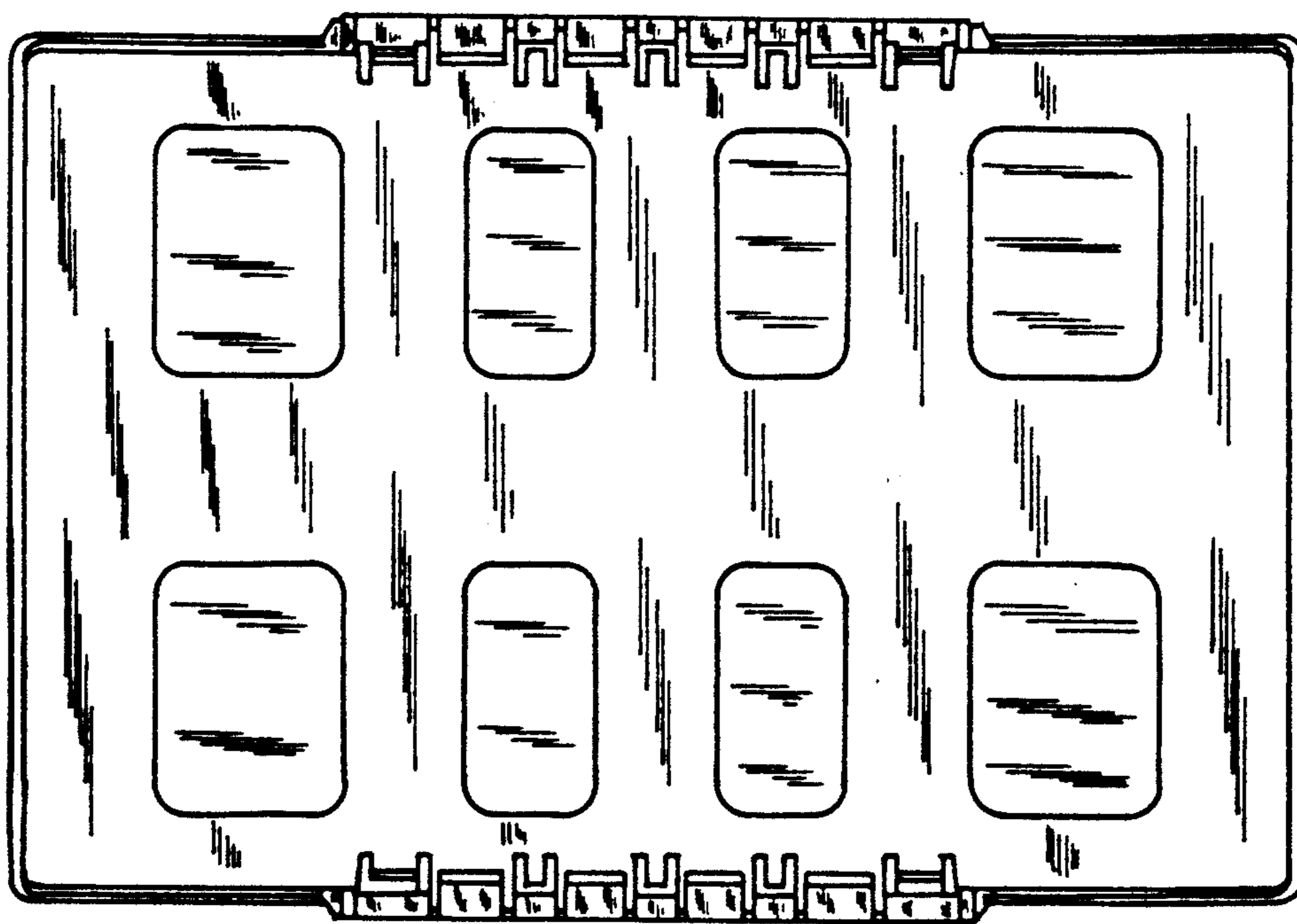

FIG. 2

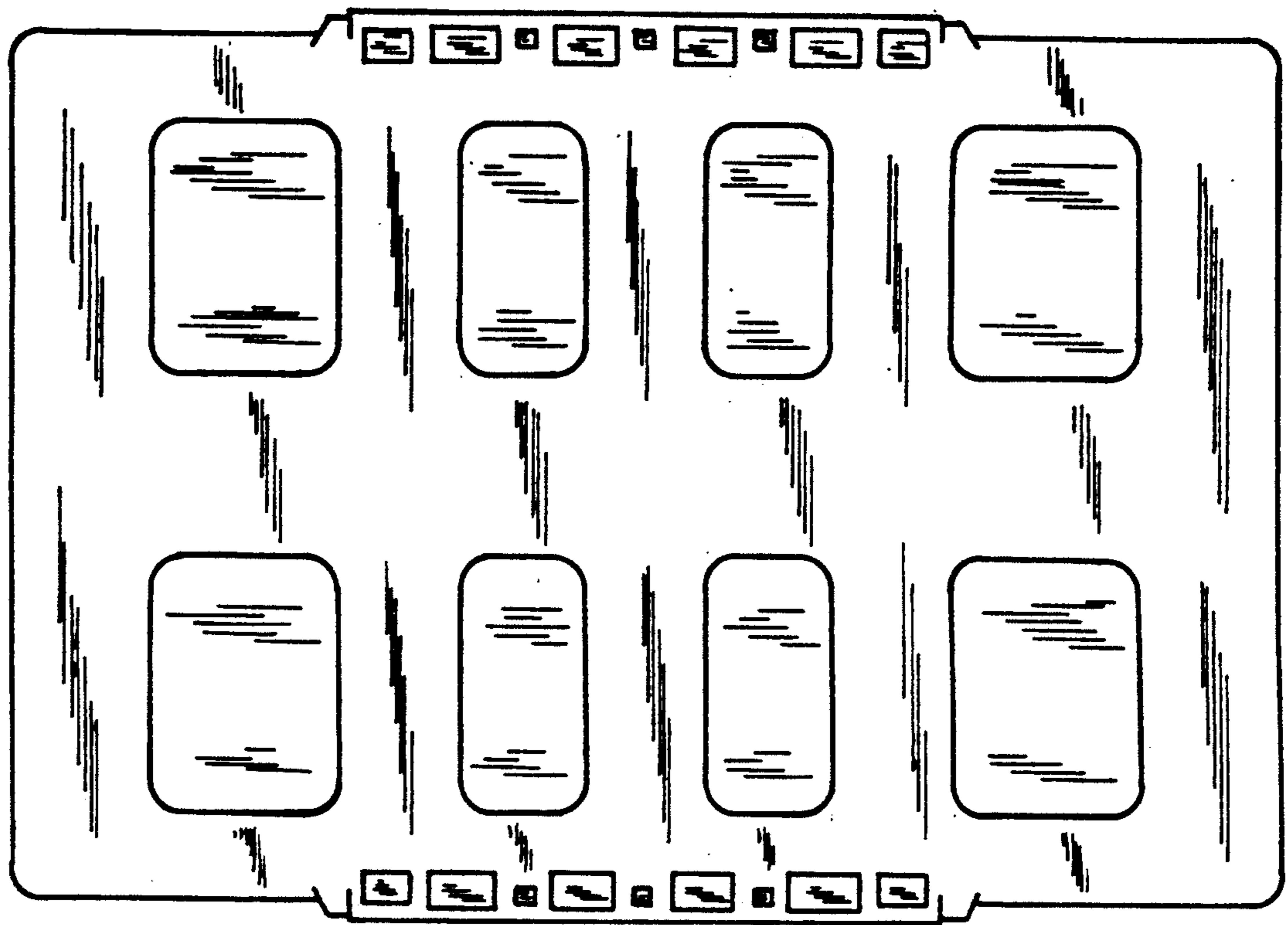

FIG. 3



FIG. 4



FIG. 5