



US00D348036S

# United States Patent [19]

[11] Patent Number: Des. 348,036

Rossigno et al.

[45] Date of Patent: \*\* Jun. 21, 1994

[54] REAR SHELL FOR A BRAKE BOOSTER

5,195,421 3/1993 Shinohara et al. .... 91/369.1  
5,207,142 4/1993 Hewitt ..... 91/369.1

[75] Inventors: Louis P. Rossigno, Granger, Ind.;  
Jon R. Dodson, Niles, Mich.

Primary Examiner—Wallace R. Burke

Assistant Examiner—Melody Brown

[73] Assignee: Allied-Signal Inc., Morristown, N.J.

Attorney, Agent, or Firm—Leo H. McCormick, Jr.; Ken  
C. Decker

[\*\*] Term: 14 Years

[21] Appl. No.: 942,495

[57] CLAIM

[22] Filed: Sep. 9, 1992

The ornamental design for a rear shell for a brake  
booster, as shown.

[52] U.S. Cl. .... D12/180

[58] Field of Search ..... 91/369.1, 369.2, 369.3;  
D12/180

## DESCRIPTION

### [56] References Cited

#### U.S. PATENT DOCUMENTS

3,879,059 4/1975 Gibes ..... 296/200  
4,763,561 8/1988 Gautier ..... 91/369.1

FIG. 1 is a rear perspective of a rear shell for a brake  
booster showing our new design;

FIG. 2 is a rear elevation view thereof;

FIG. 3 is a side elevation view thereof;

FIG. 4 is a right side elevation view thereof; and,

FIG. 5 is a front perspective view thereof.

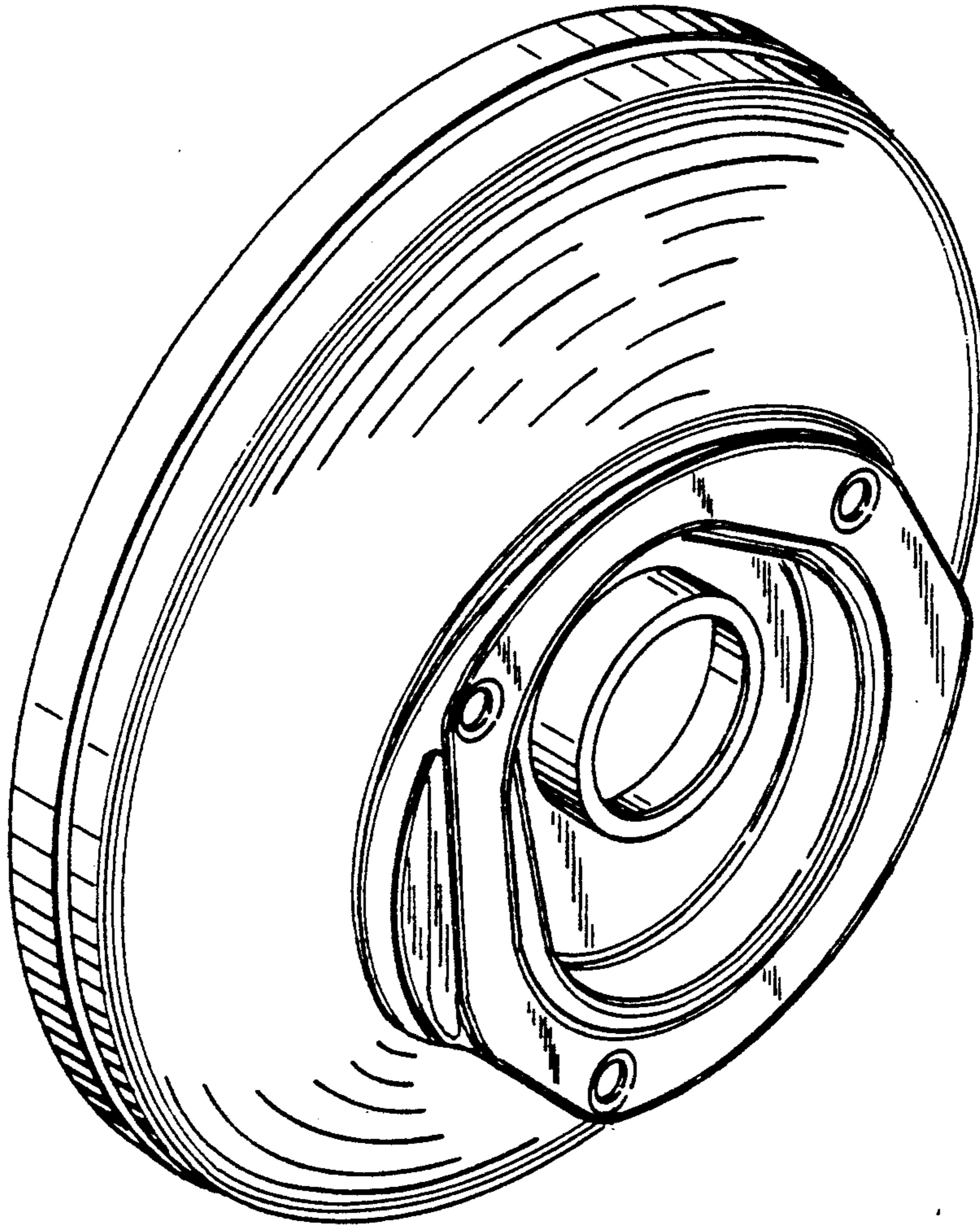
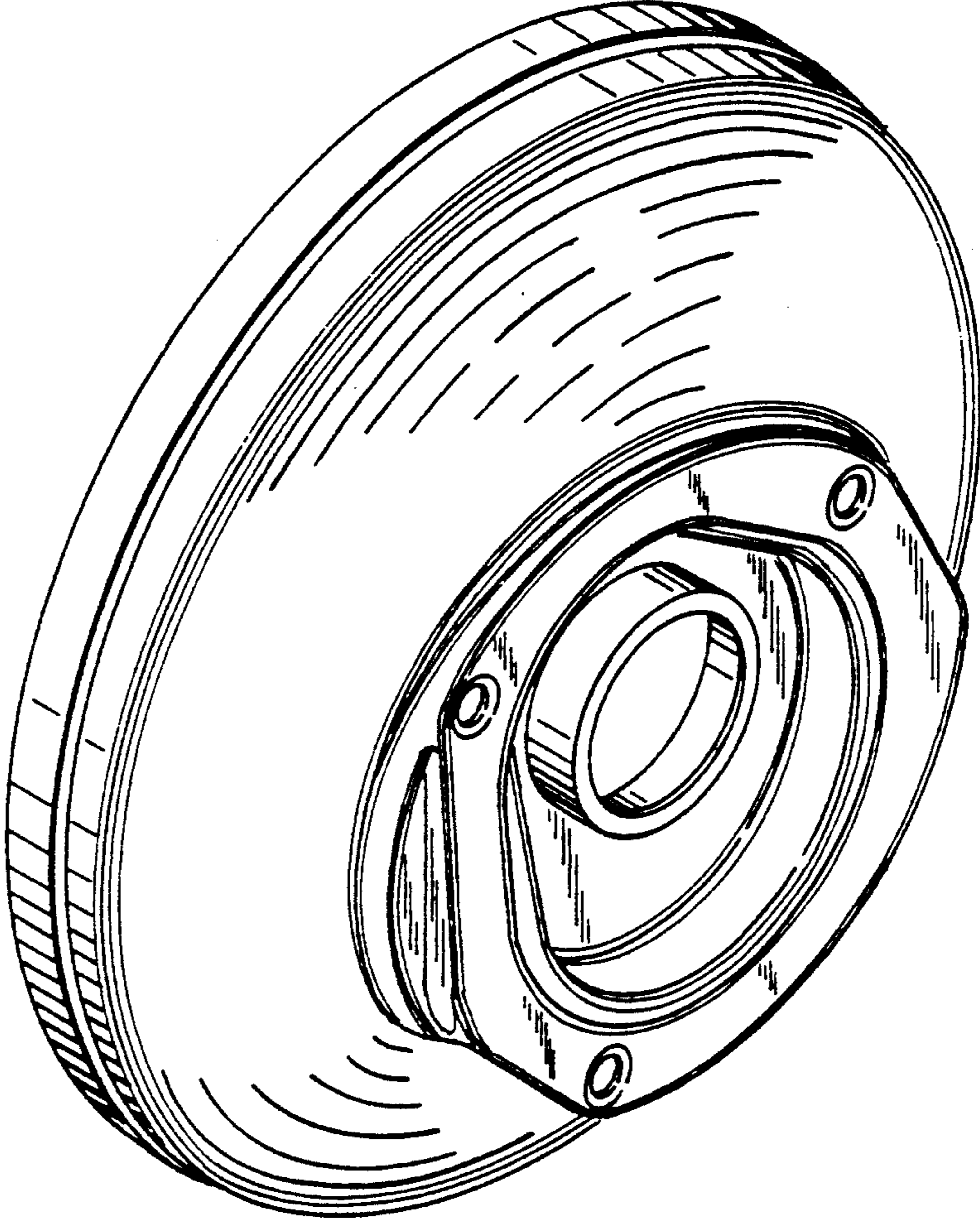

FIG. 1



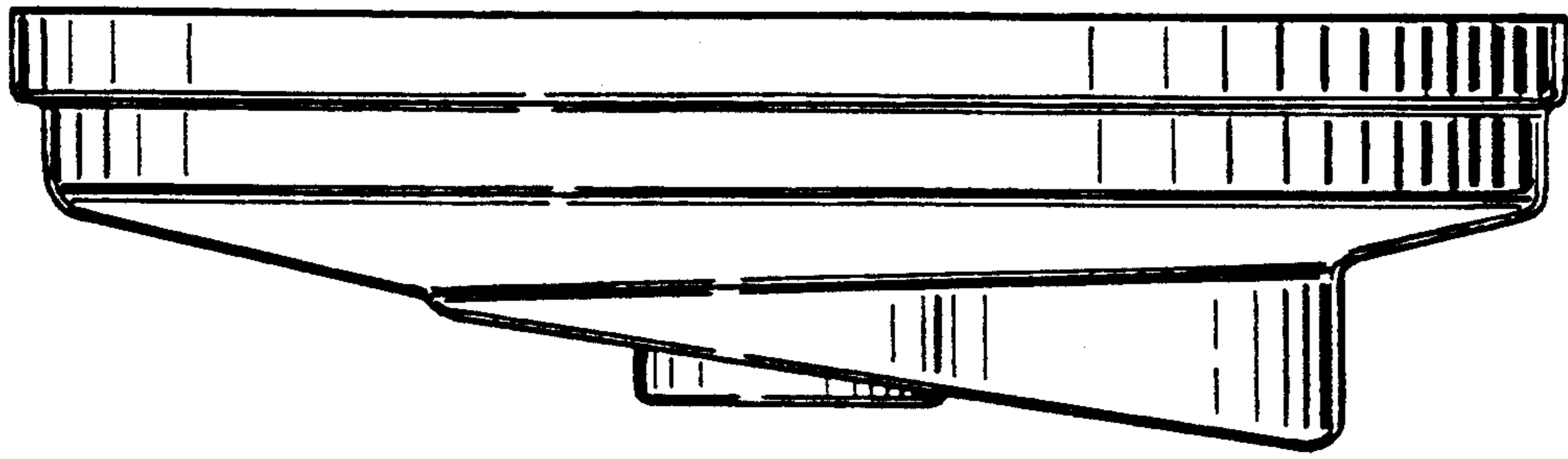

FIG. 4

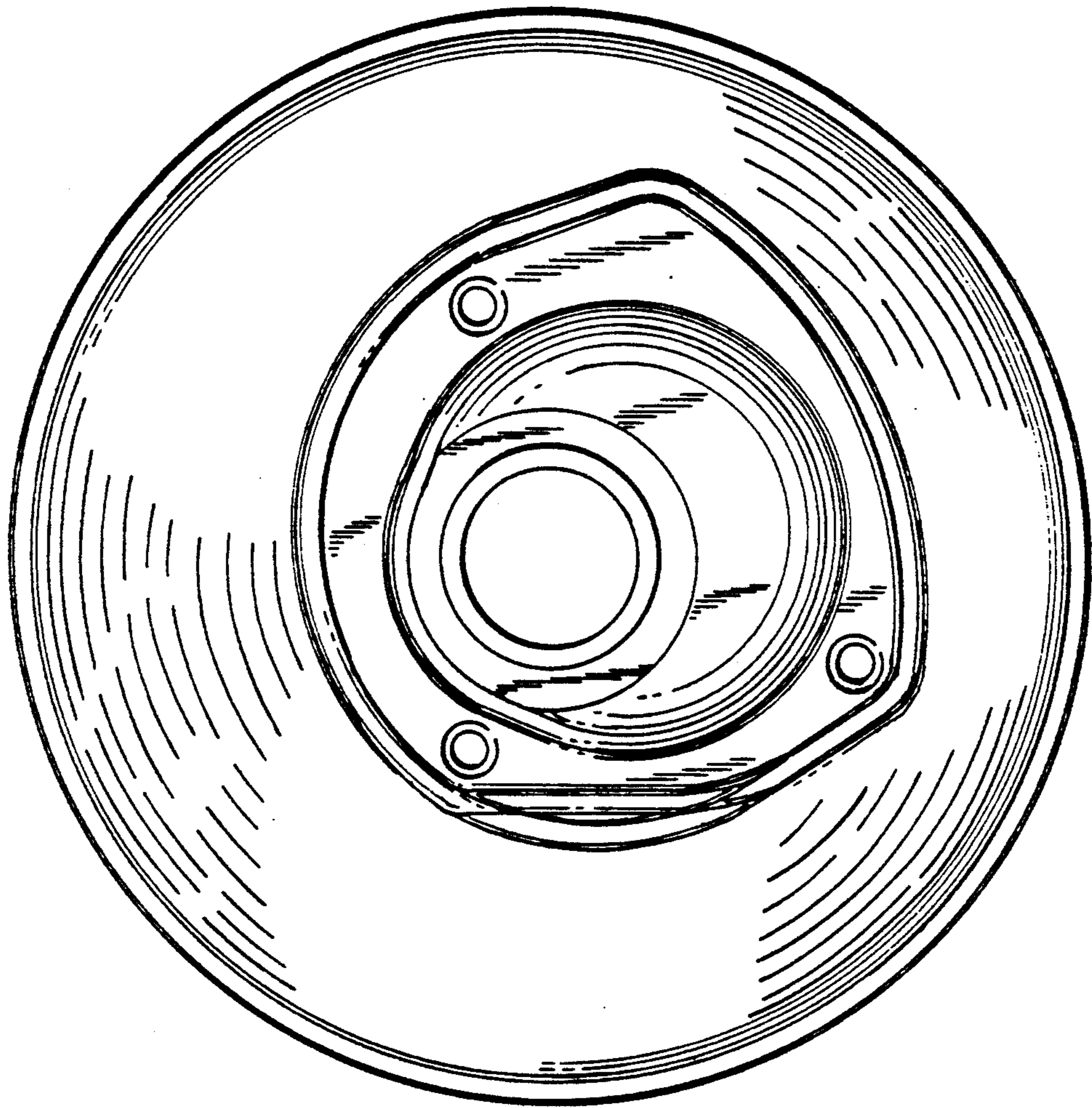

FIG. 2

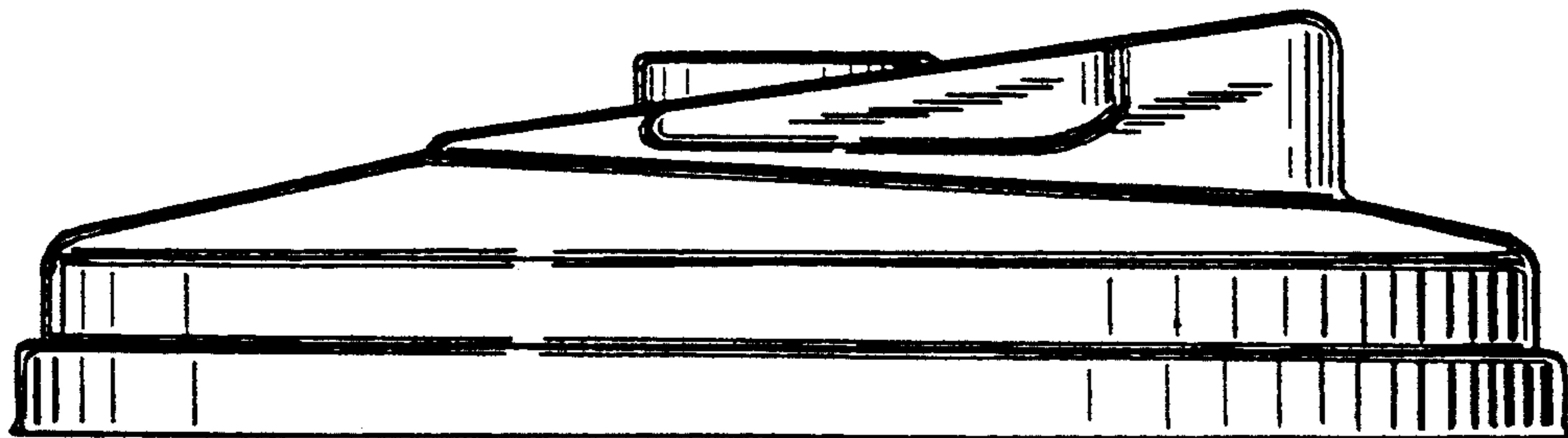

FIG. 3

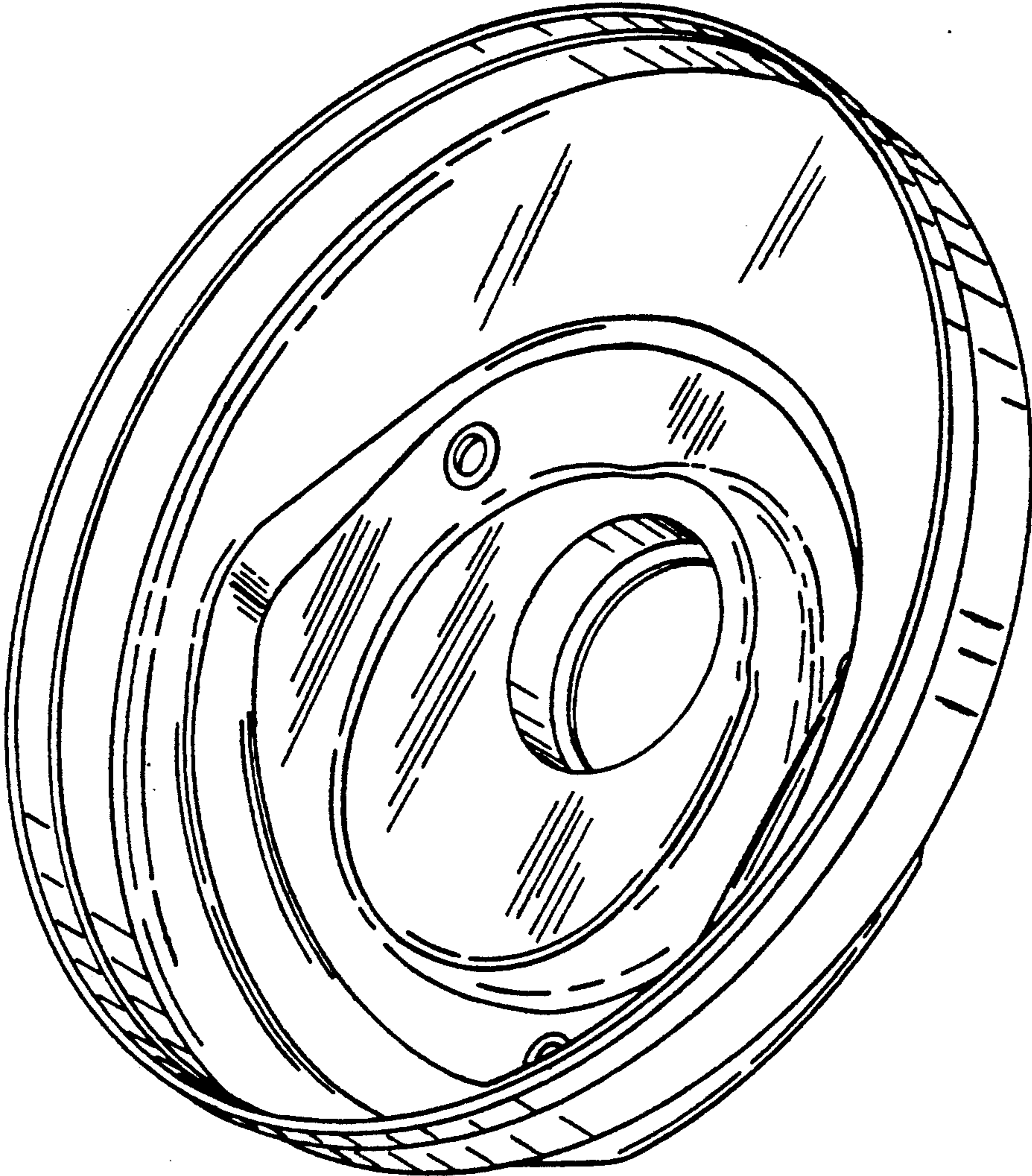

FIG. 5