



US00D347988S

# United States Patent [19]

[11] Patent Number: Des. 347,988

Thorne

[45] Date of Patent: \*\* Jun. 21, 1994

[54] BICYCLE ANTI-THEFT ASSEMBLY

[76] Inventor: Steve Thorne, 462 Elwood Ave., Oakland, Calif. 94610

[\*\*] Term: 14 Years

[21] Appl. No.: 3,338

[22] Filed: Jan. 5, 1993

[52] U.S. Cl. .... D8/333

[58] Field of Search ..... D8/330-331, D8/333, 336, 343; 70/14-18, 57, 58, 233-236

[56] References Cited

U.S. PATENT DOCUMENTS

- D. 27,264 6/1897 Fraim ..... D8/334
- D. 221,417 8/1971 Prichard .
- 602,279 4/1898 Battersby .
- 621,391 3/1899 Turner .
- 3,747,376 7/1973 White .
- 3,748,876 7/1973 Mathews .
- 3,908,414 9/1975 Thorne .
- 4,760,718 8/1988 Muramatsu .

FOREIGN PATENT DOCUMENTS

- 1083843 8/1980 Canada .
- 335862 4/1921 Fed. Rep. of Germany .

Primary Examiner—Brian N. Vinson  
Attorney, Agent, or Firm—Townsend & Townsend  
Khourie & Crew

[57] CLAIM

The ornamental design for a bicycle anti-theft assembly, as shown and described.

DESCRIPTION

FIG. 1 is a front and left side perspective view of a bicycle anti-theft assembly showing my new design, the broken-line disclosure of a plunger-type lock element being for illustrative purposes only and forming no part of the claimed design;

FIG. 2 is an enlarged top plan view thereof;

FIG. 3 is an enlarged front elevational view thereof;

FIG. 4 is an enlarged left side elevational view thereof;

FIG. 5 is an enlarged right side elevational view thereof;

FIG. 6 is an enlarged rear elevational view thereof;

FIG. 7 is an enlarged bottom plan view thereof;

FIG. 8 is a front and left side perspective view of a bicycle anti-theft assembly showing a second embodiment of the claimed design, the broken-line disclosure of a padlock element being for illustrative purposes only and forming no part of the claimed design;

FIG. 9 is an enlarged top plan view thereof;

FIG. 10 is an enlarged front elevational view thereof, the rear being identical in appearance;

FIG. 11 is an enlarged right side elevational view thereof, the left side being a mirror image of that shown; and,

FIG. 12 is an enlarged bottom plan view thereof.

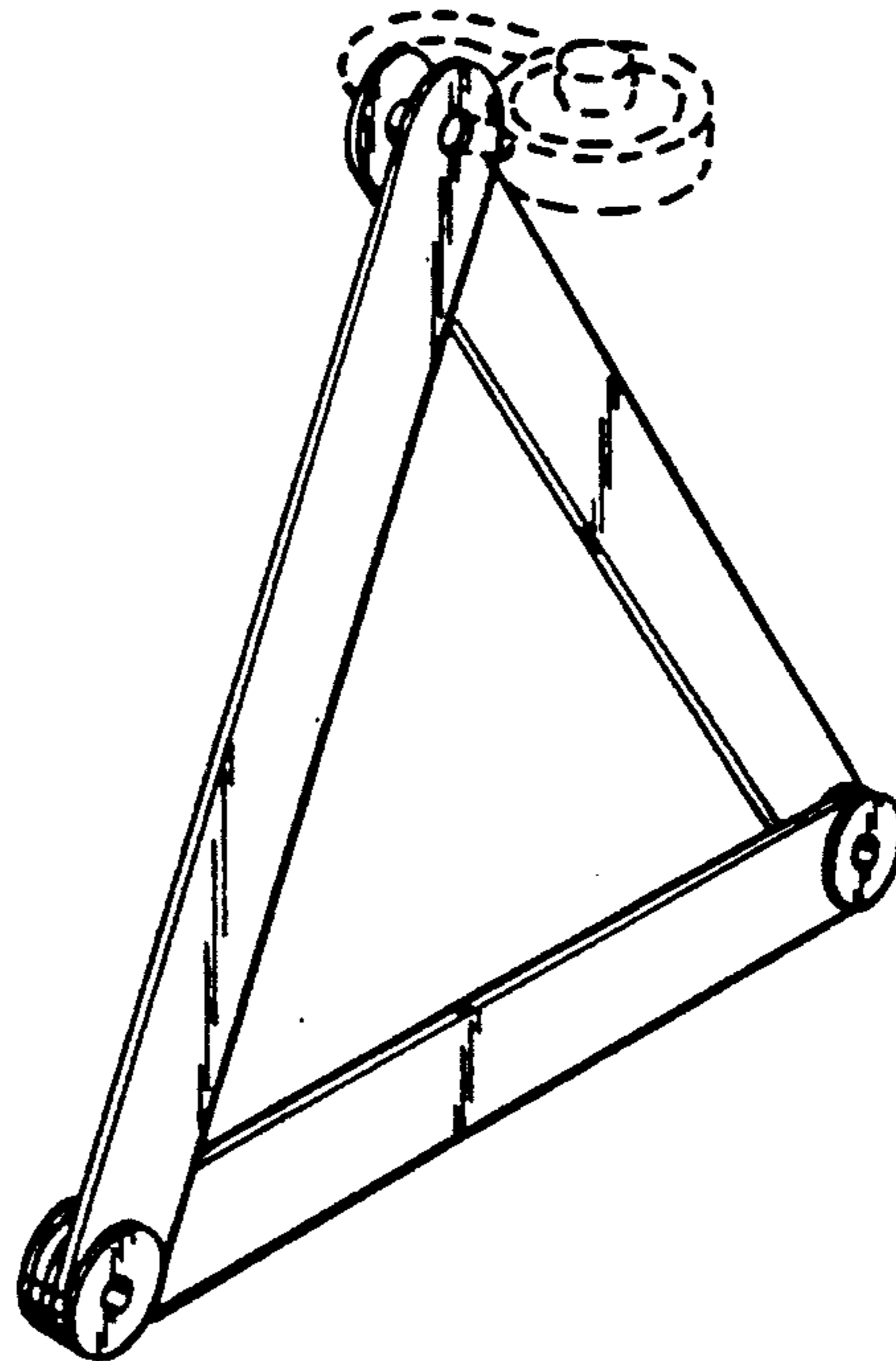
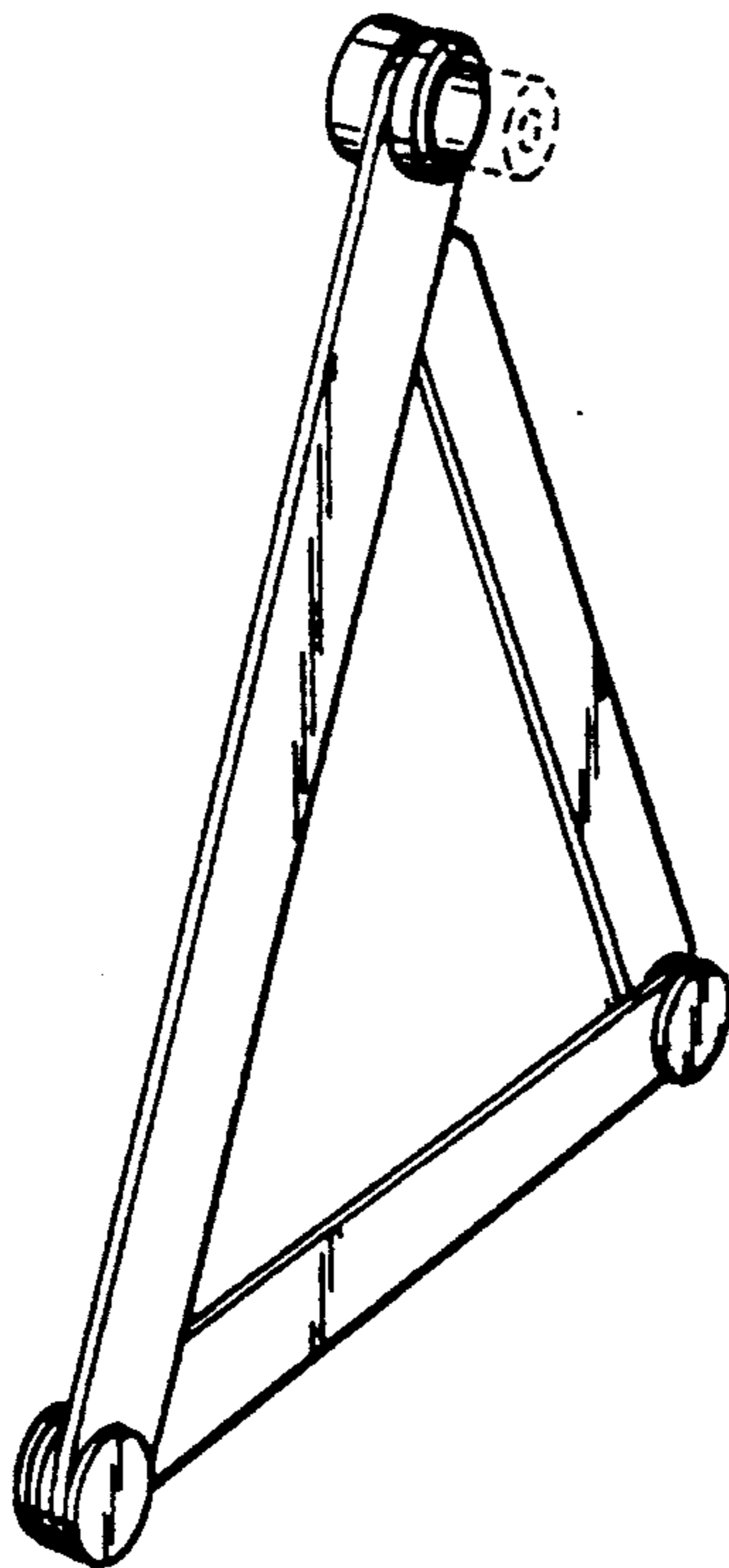

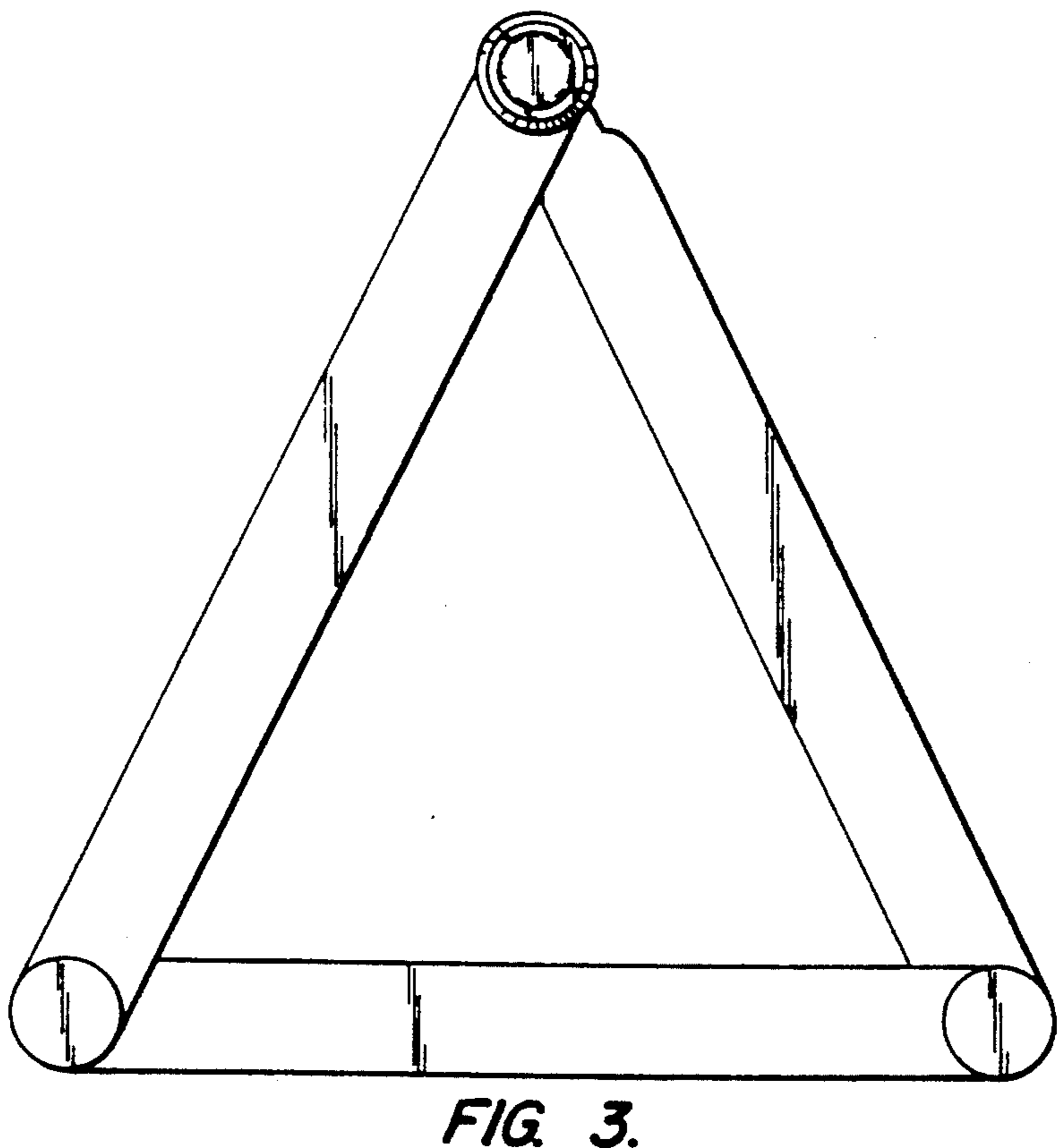
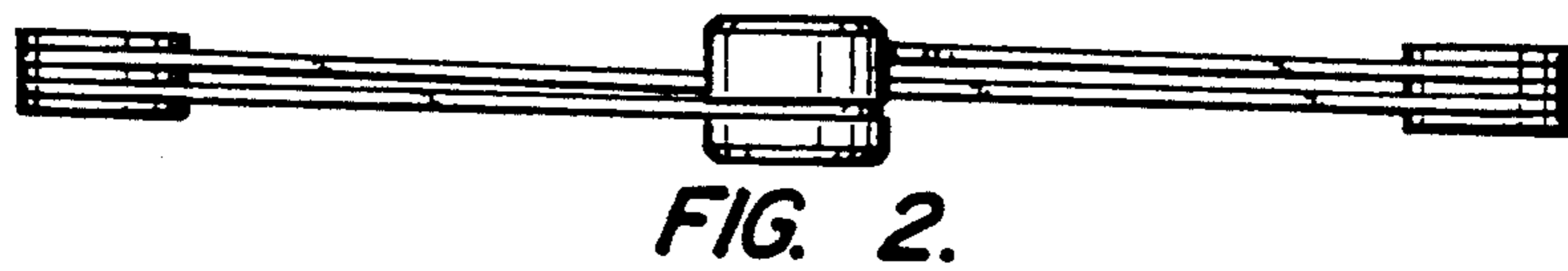
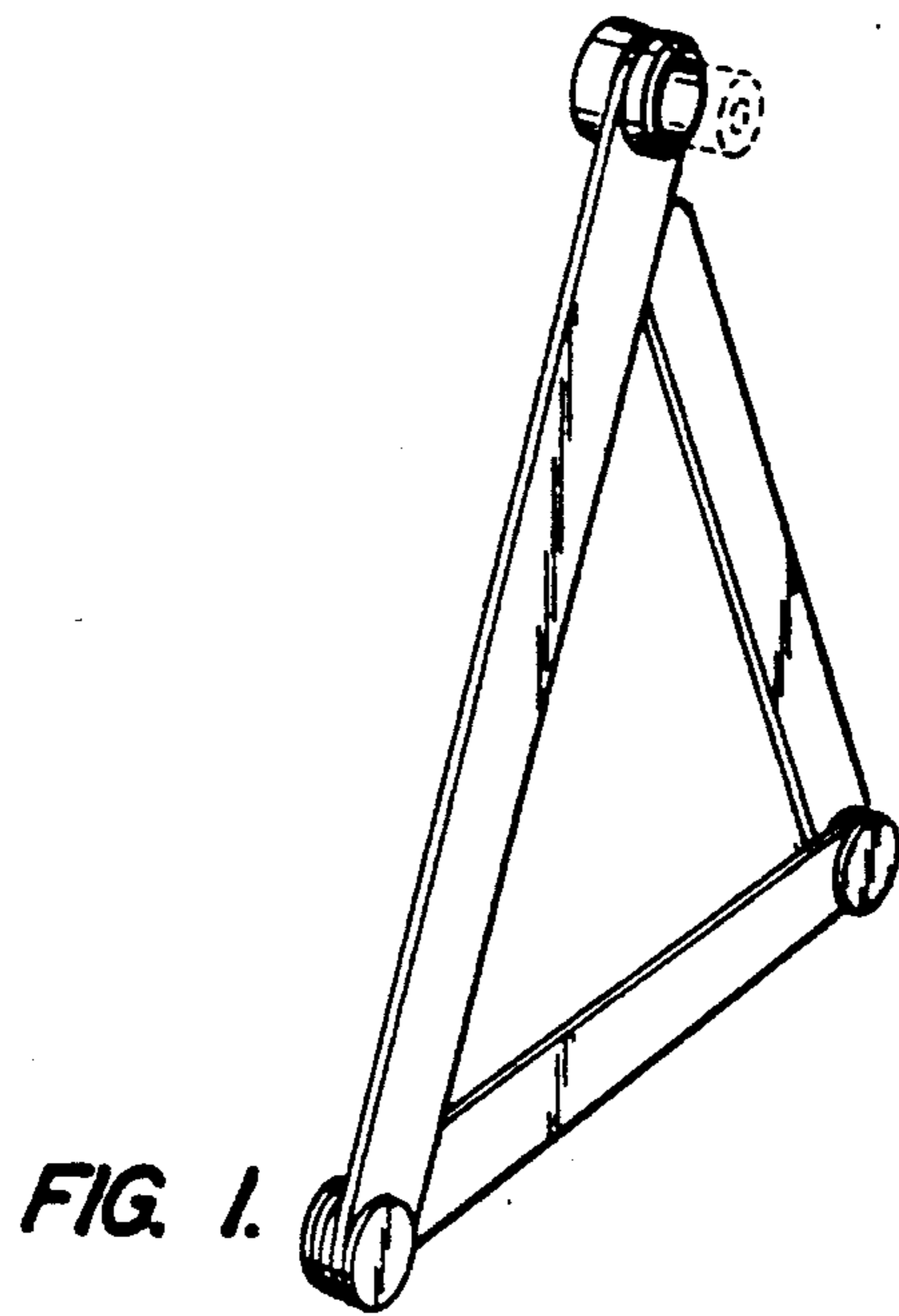

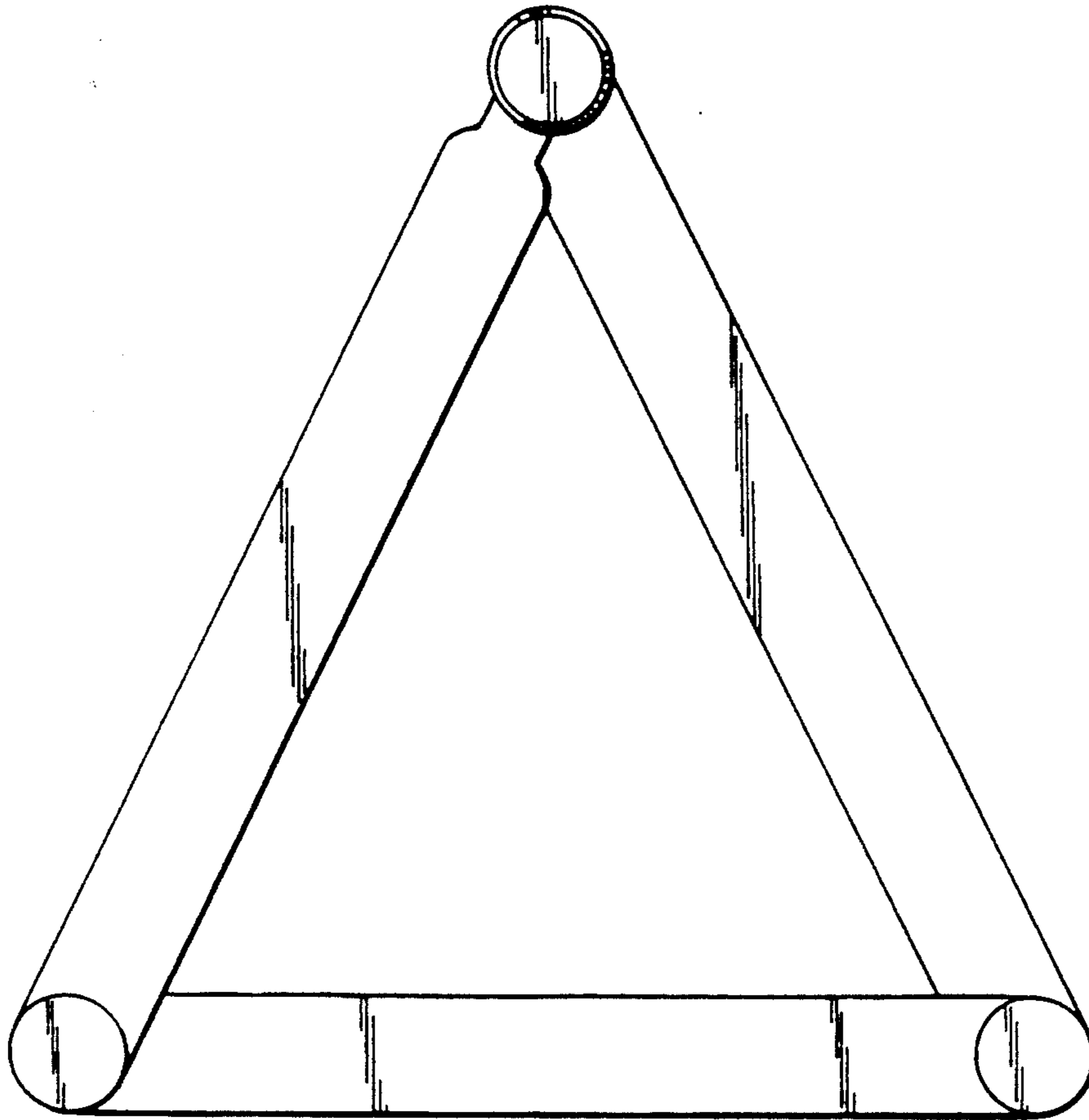

*FIG. 6.*



*FIG. 7.*

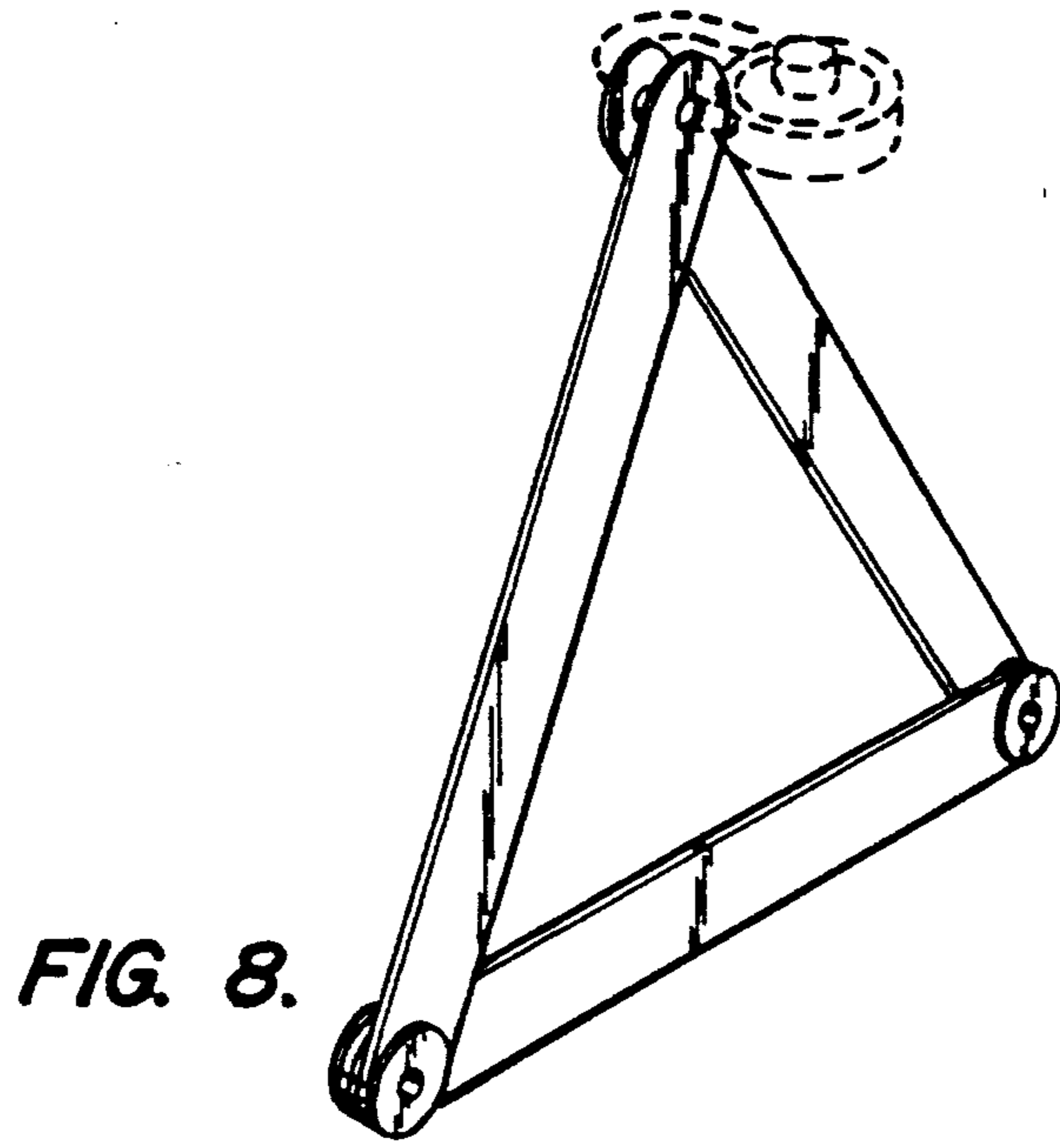

FIG. 8.

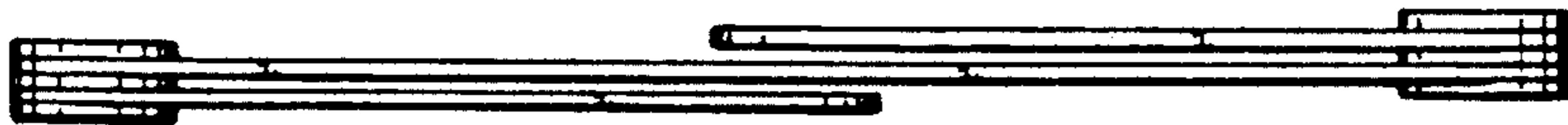

FIG. 9.

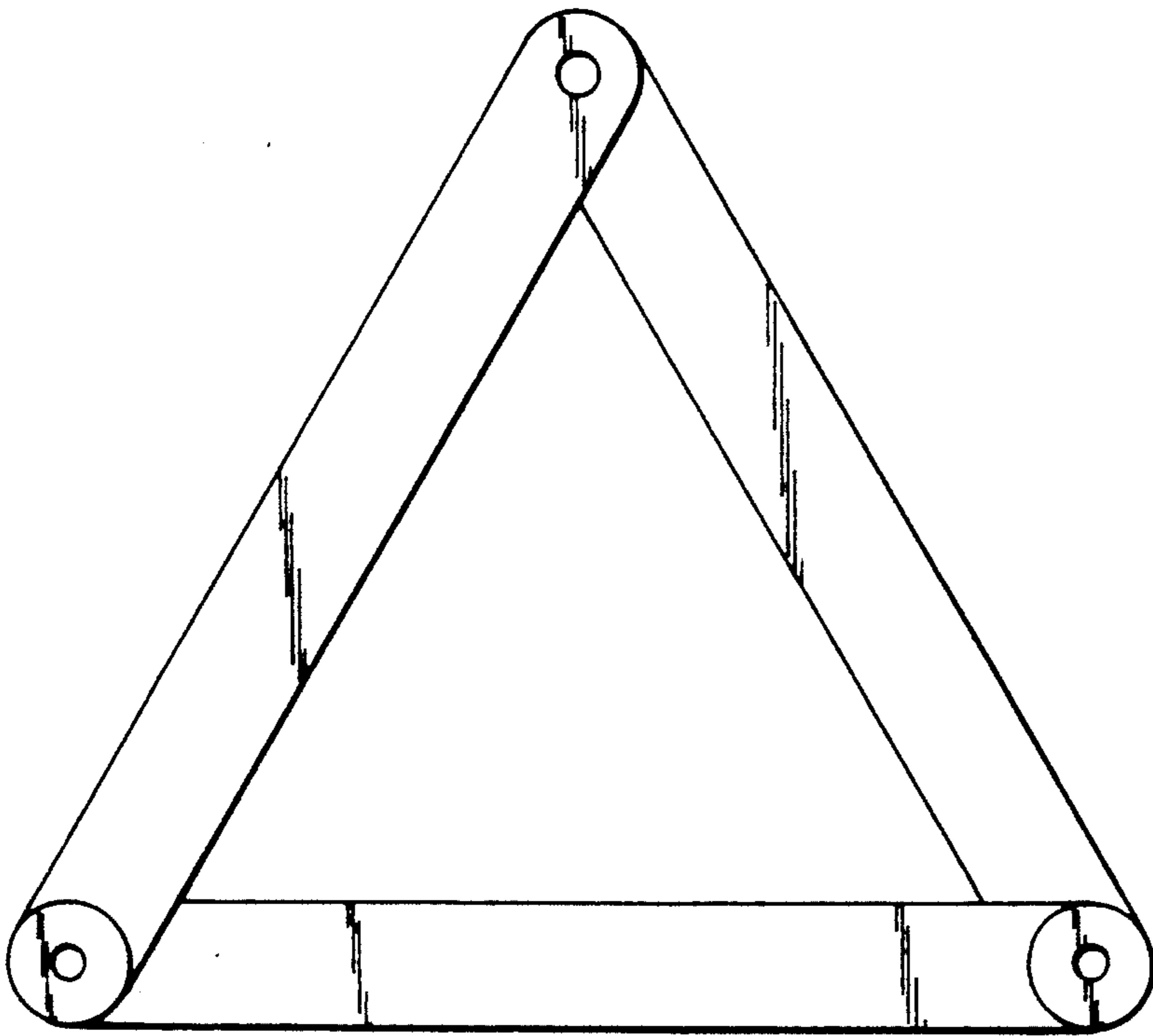

FIG. 10.

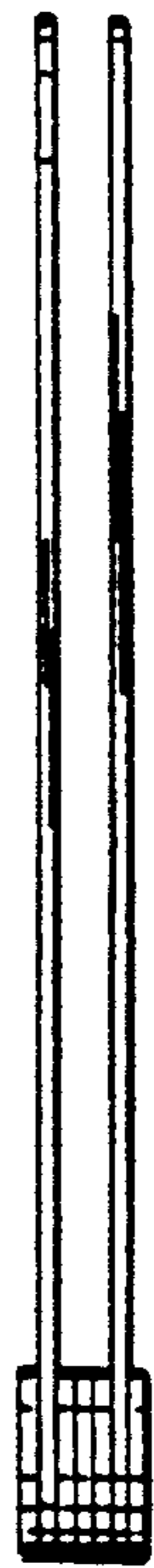

FIG. 11.

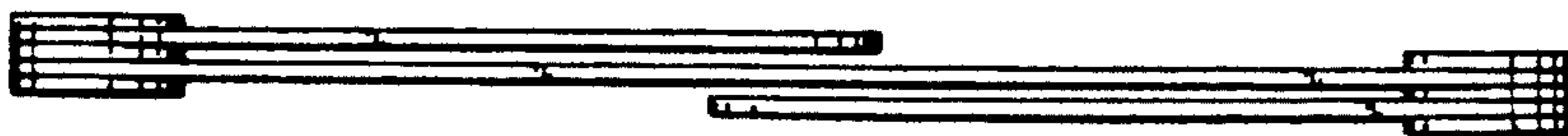

FIG. 12.