



US00D347902S

United States Patent [19]

Stutts

[11] Patent Number: **Des. 347,902**

[45] Date of Patent: **** Jun. 14, 1994**

[54] ADJUSTABLE TRUCK LIGHT BAR

[76] Inventor: **Hugh Stutts**, Rte. 3, Box 465,
Leighton, Ala. 35646

[**] Term: **14 Years**

[21] Appl. No.: **764,375**

[22] Filed: **Sep. 23, 1991**

[52] U.S. Cl. **D12/222; D26/35**

[58] Field of Search **362/61, 80, 80.1, 82,
362/83, 83.3; 280/756; D26/28-36; D12/156,
157**

[56] References Cited

U.S. PATENT DOCUMENTS

D. 284,557	7/1986	Ferenc	D26/35
D. 295,084	4/1988	Weber	D26/35
D. 310,793	9/1990	Castagna	D26/35
4,286,309	8/1981	Rasinski	362/61
4,692,845	8/1987	Widhalm	362/80

OTHER PUBLICATIONS

J.C. Whitney Auto Accessories Catalog, p. 46, Light Bar for Truck.

Primary Examiner—Susan J. Lucas

Attorney, Agent, or Firm—Terry M. Gernstein

[57] CLAIM

The ornamental design for an adjustable truck light bar, as shown and described.

DESCRIPTION

FIG. 1 is a perspective view of the adjustable truck light bar embodying the design of the present invention; FIG. 2 is a front end elevational view thereof; FIG. 3 is a rear end elevational view thereof; FIG. 4 is a side elevational view thereof; FIG. 5 is a opposite side elevational view thereof; FIG. 6 is a top plan view thereof; and, FIG. 7 is a bottom view thereof.

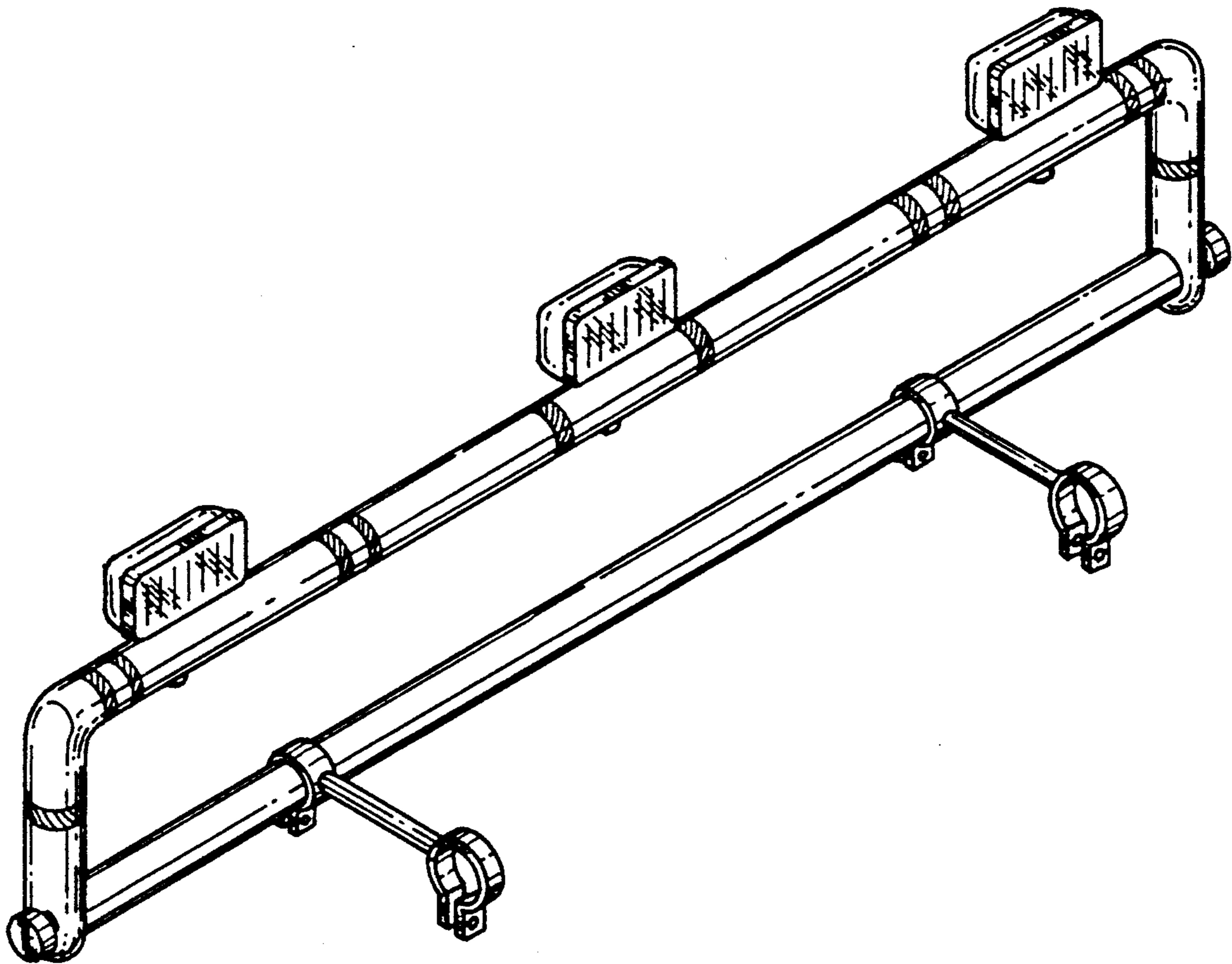

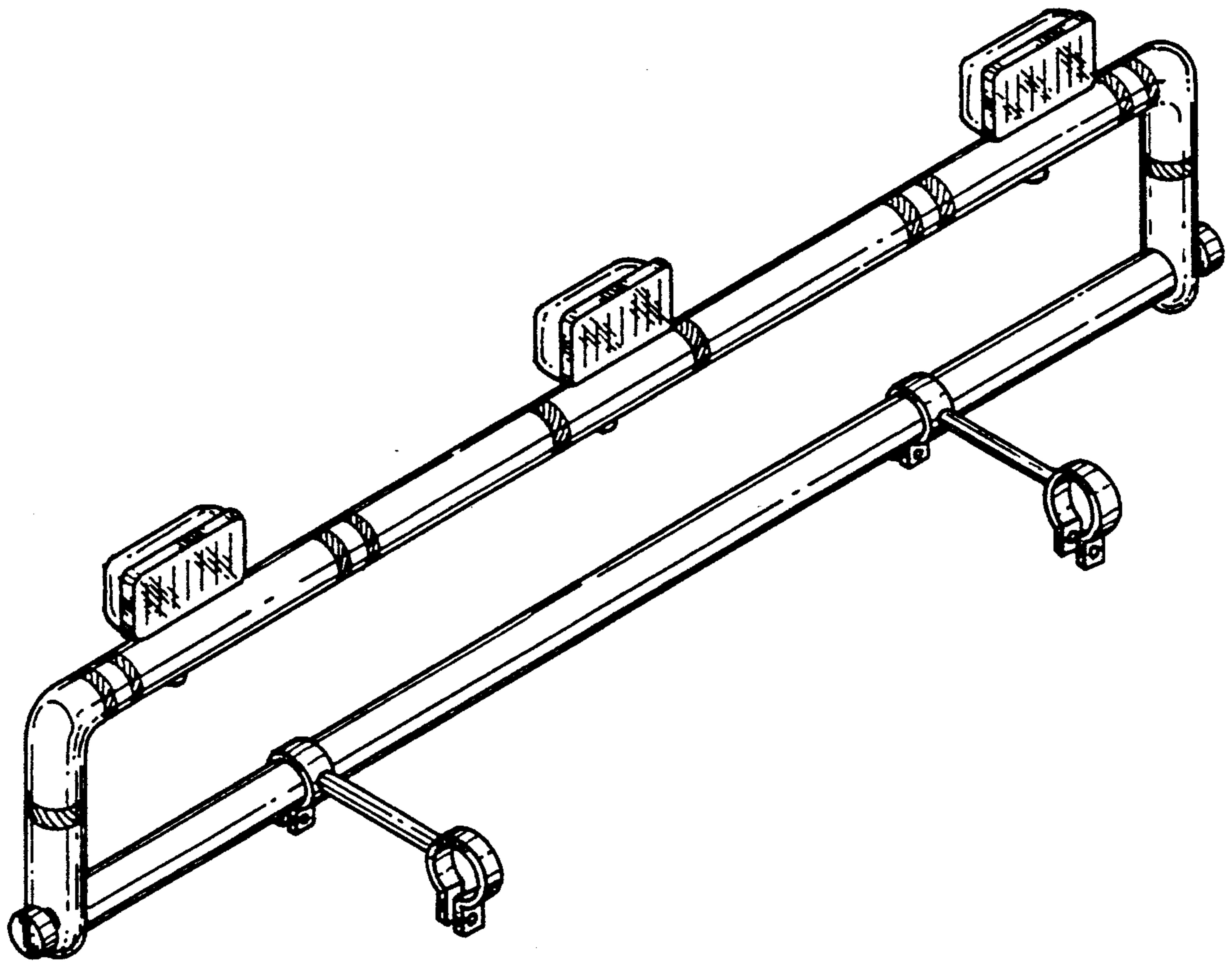

FIG. 1

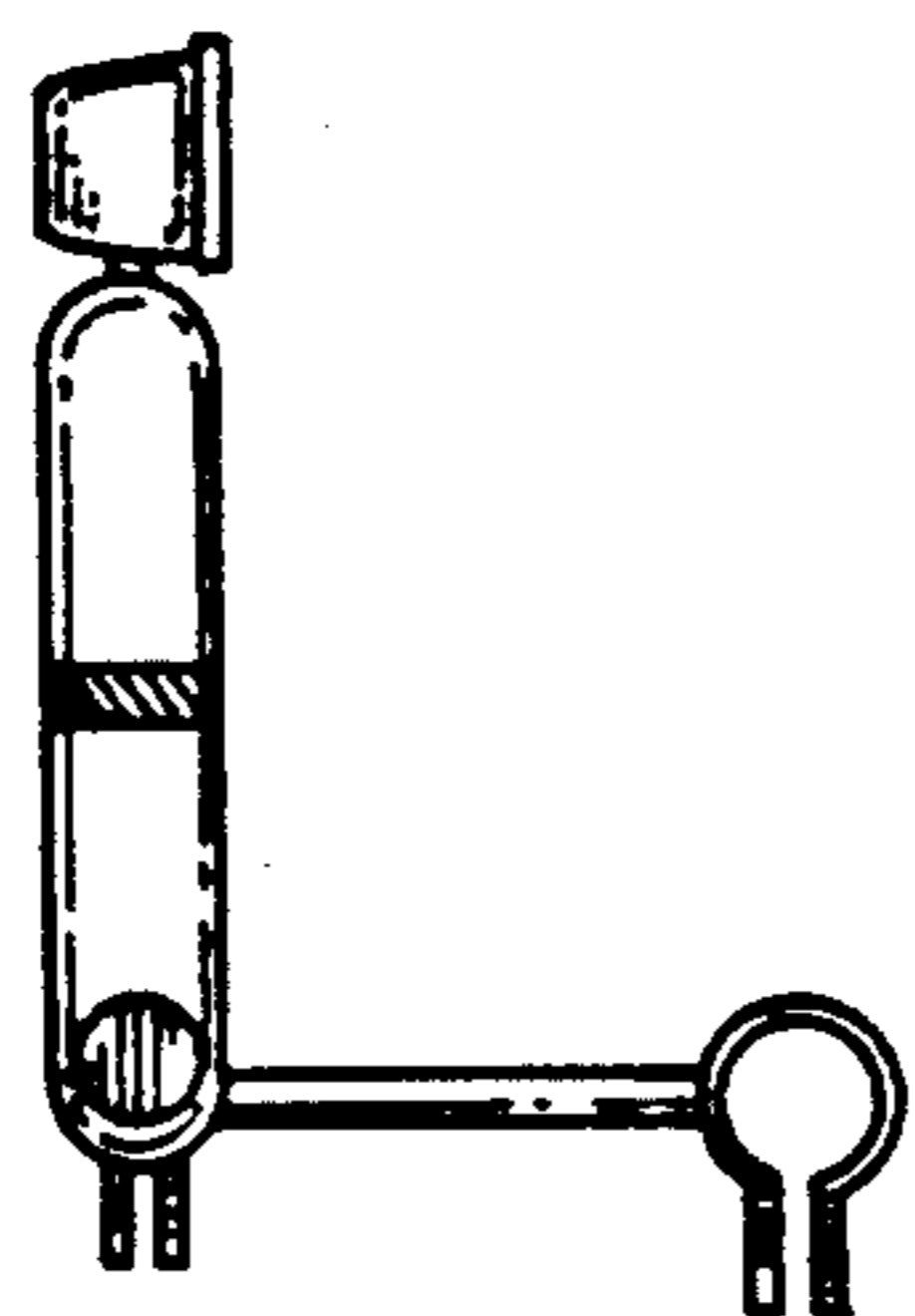

FIG. 2

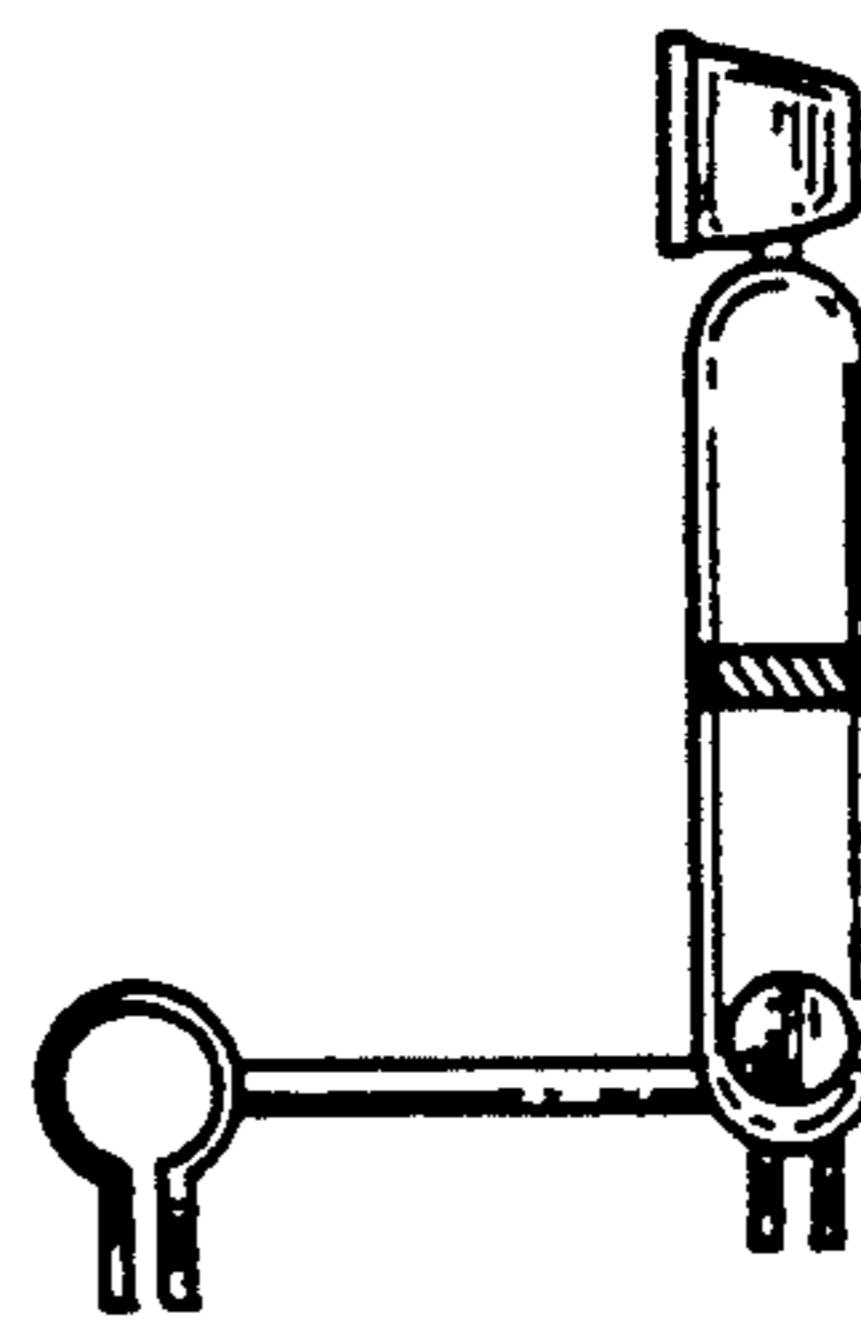

FIG. 3

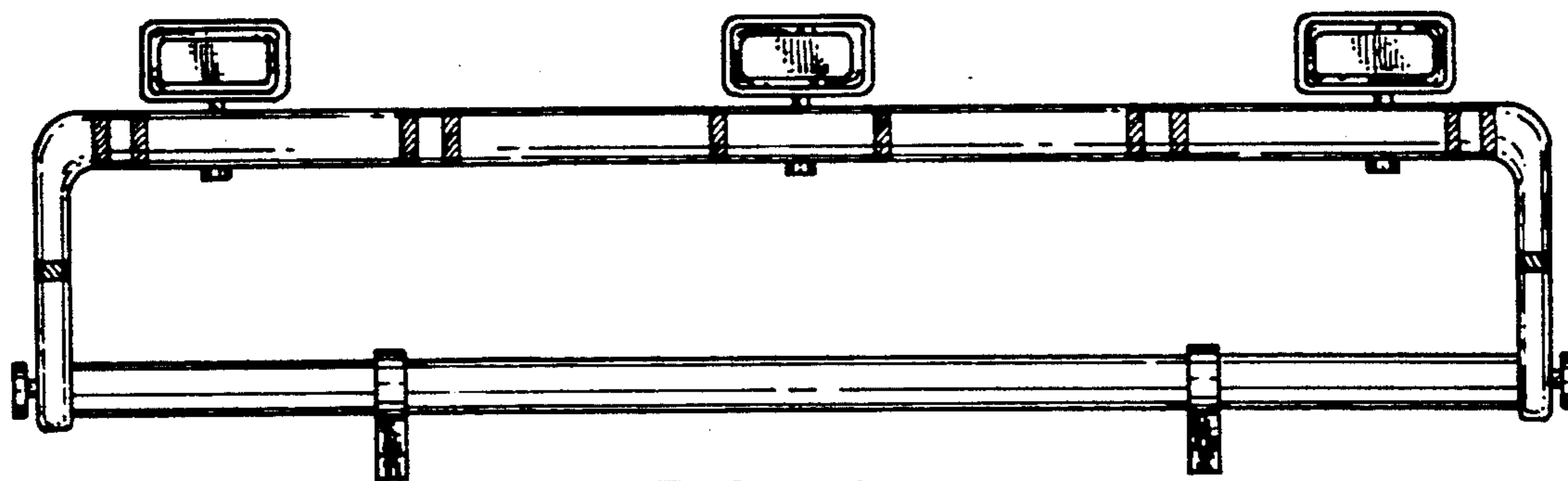

FIG. 4

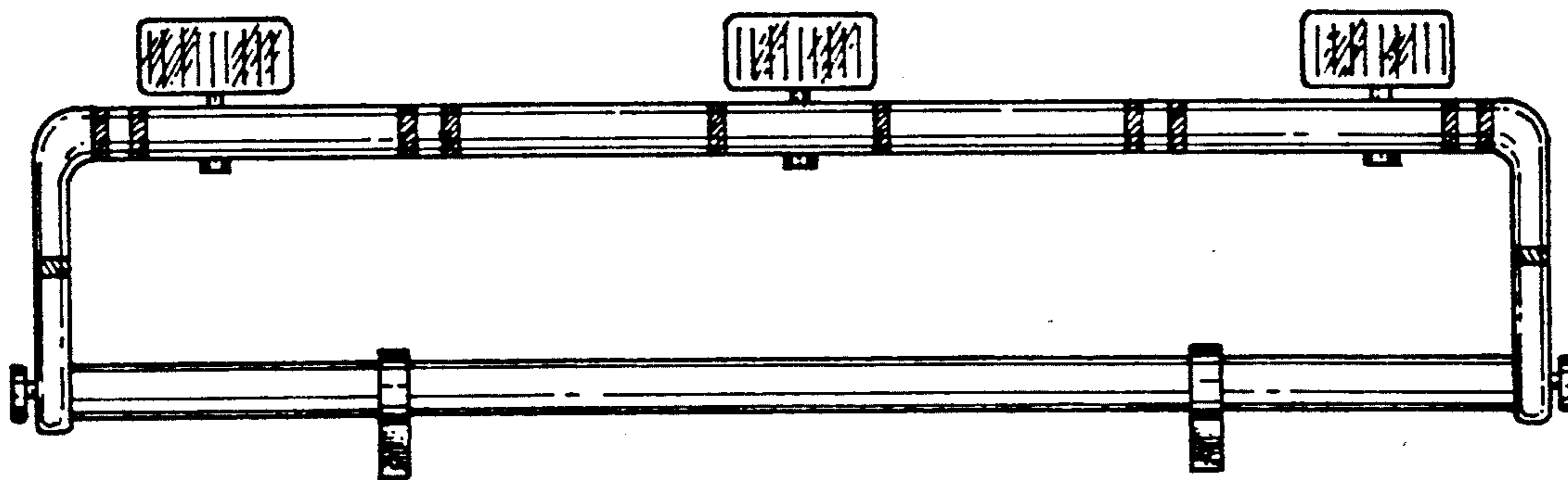

FIG. 5

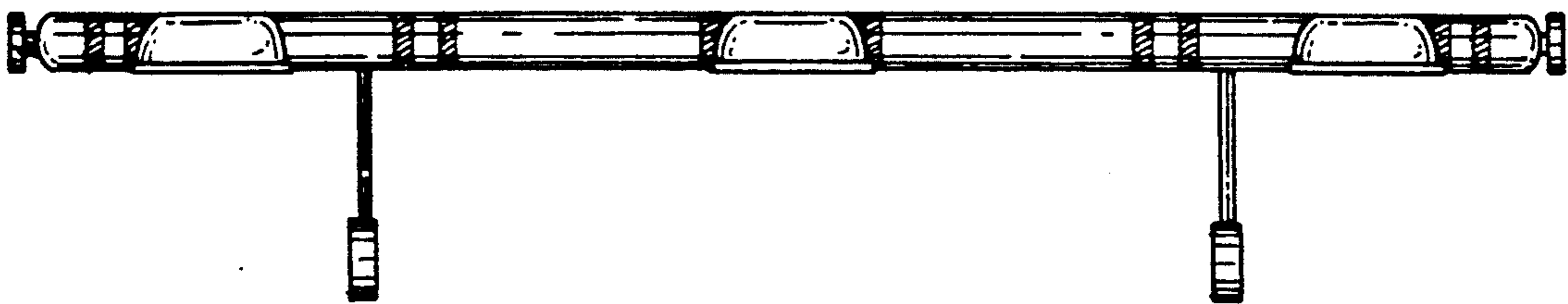

FIG. 6

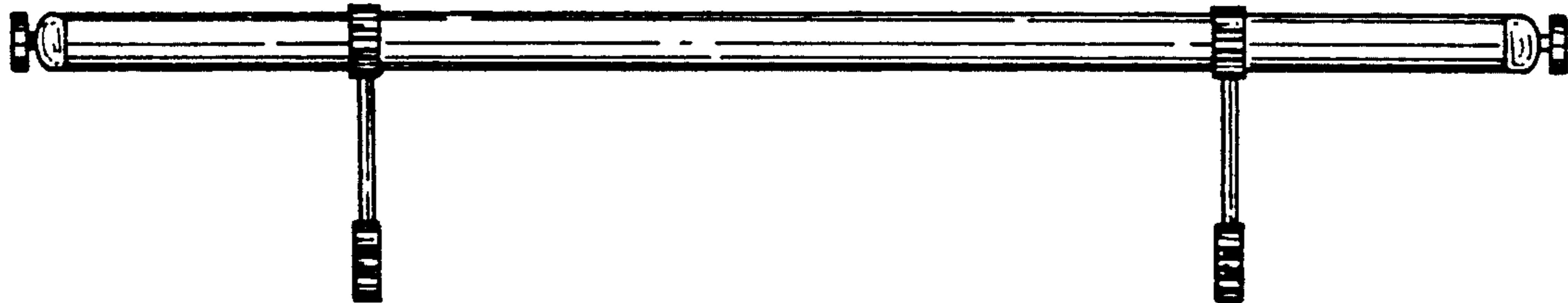

FIG. 7