



US00D347821S

United States Patent [19]
Few

[11] **Patent Number: Des. 347,821**
[45] **Date of Patent: ** Jun. 14, 1994**

- [54] **RECREATIONAL VEHICLE CHOCK**
- [75] **Inventor: Jeffrey P. Few, West Hills, Calif.**
- [73] **Assignee: Norco Industries, Inc., Compton, Calif.**
- [**] **Term: 14 Years**
- [21] **Appl. No.: 3,359**
- [22] **Filed: Jan. 8, 1993**
- [52] **U.S. Cl. D12/197**
- [58] **Field of Search 188/74, 2 R, 32; D12/217**

- [56] **References Cited**
- U.S. PATENT DOCUMENTS**
- 2,850,117 9/1958 Gerswehl, Sr. D12/217
- 2,851,127 9/1958 Smith D12/217
- 4,715,480 12/1987 Anderson 188/74
- 4,934,489 6/1990 Jackson 188/74

OTHER PUBLICATIONS
Photographs of 'Rock Stopper' Device.

Photographs of 'Herndon Wheellock'.
Primary Examiner—Wallace R. Burke
Assistant Examiner—Melody Brown
Attorney, Agent, or Firm—Fulwider, Patton, Lee & Utecht

[57] **CLAIM**
The ornamental design for a recreational vehicle chock, as shown.

DESCRIPTION
FIG. 1 is a perspective view of a recreational vehicle chock showing my new design;
FIG. 2 is a right side elevational view thereof, in enlarged scale;
FIG. 3 is a front elevational view thereof, in enlarged scale;
FIG. 4 is a left side elevational view thereof, in enlarged scale;
FIG. 5 is a rear elevational view thereof, in enlarged scale;
FIG. 6 is a top plan view thereof, in enlarged scale; and,
FIG. 7 is a bottom plan view thereof, in enlarged scale.

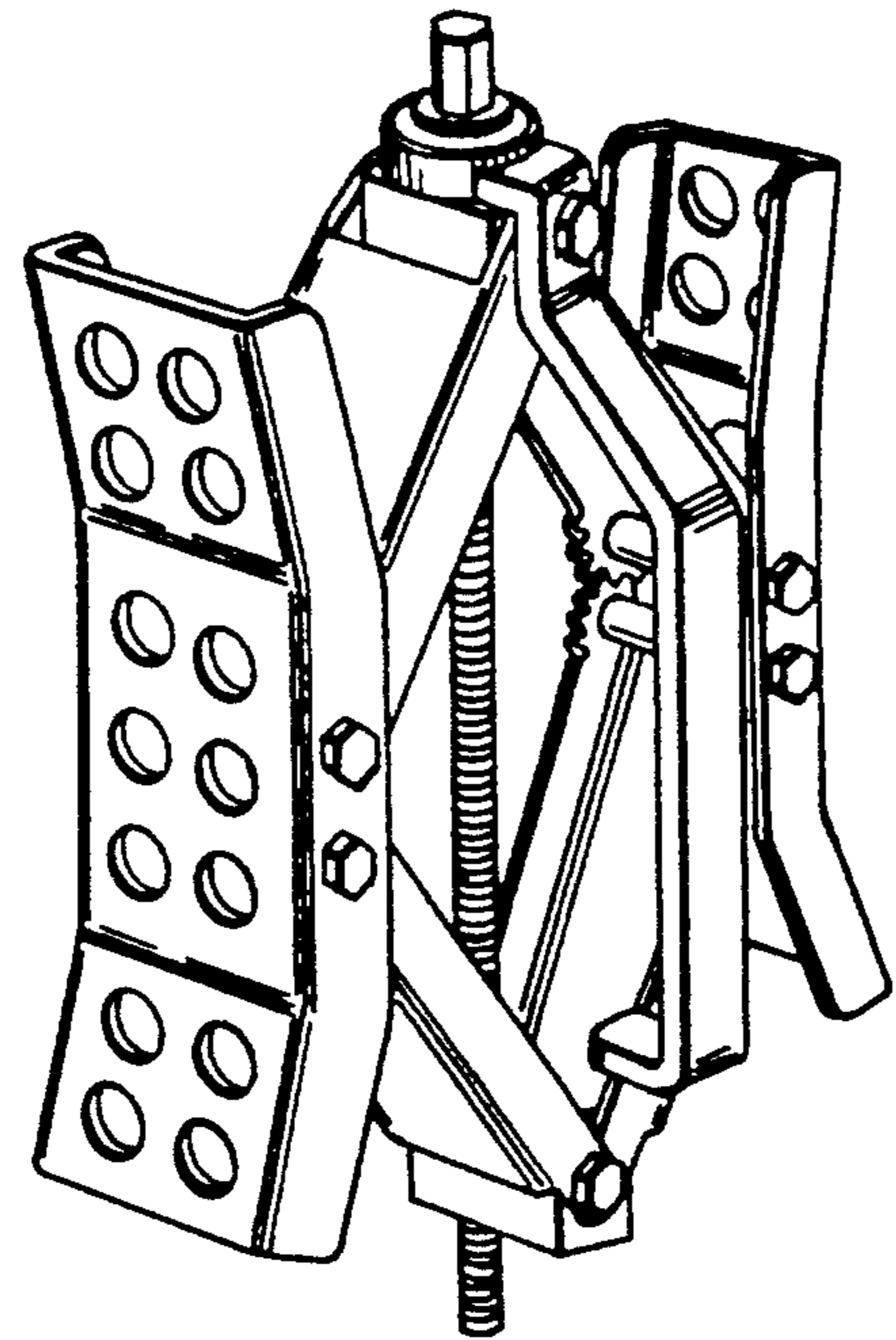

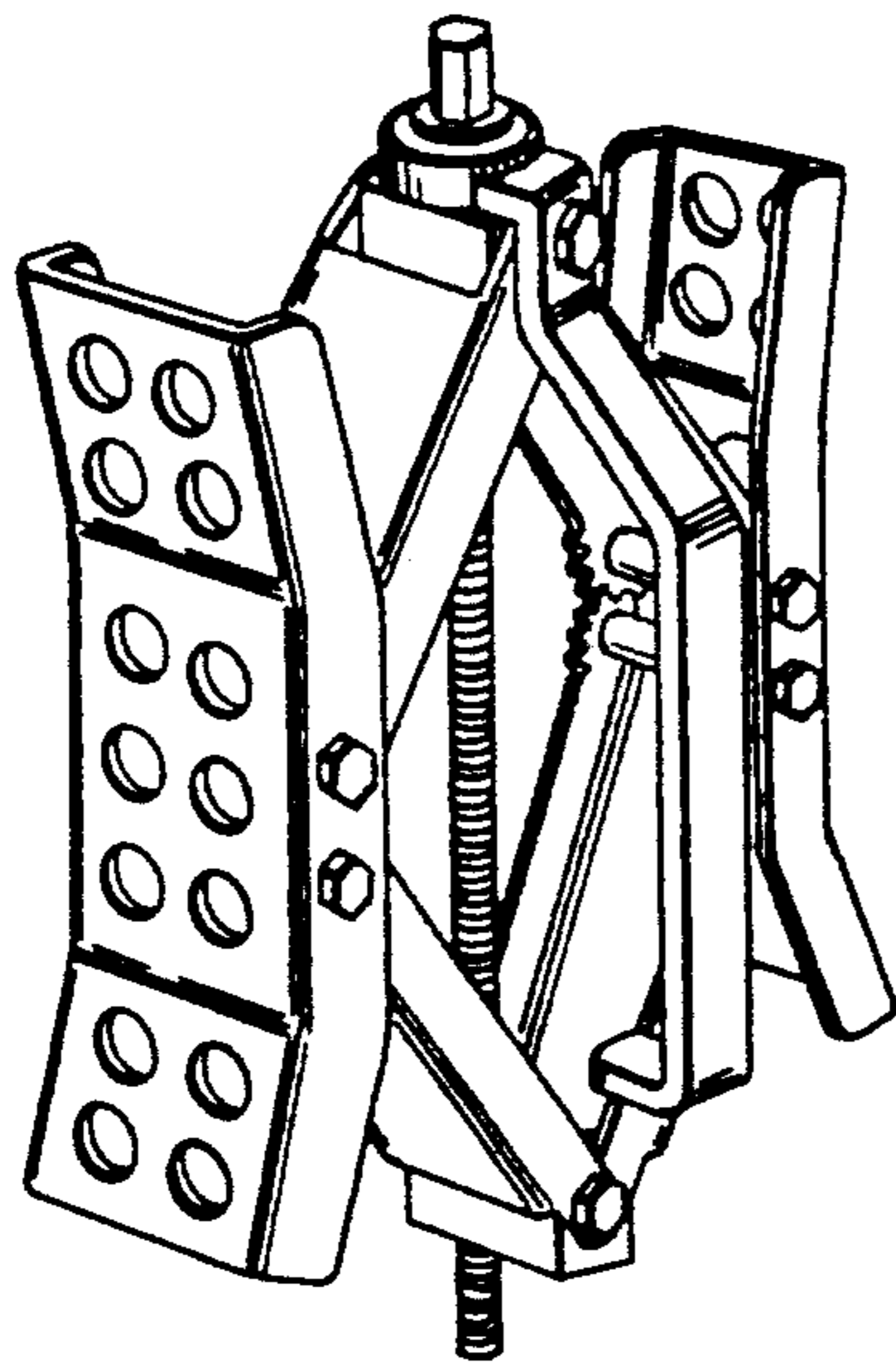

FIG. 1

FIG. 2

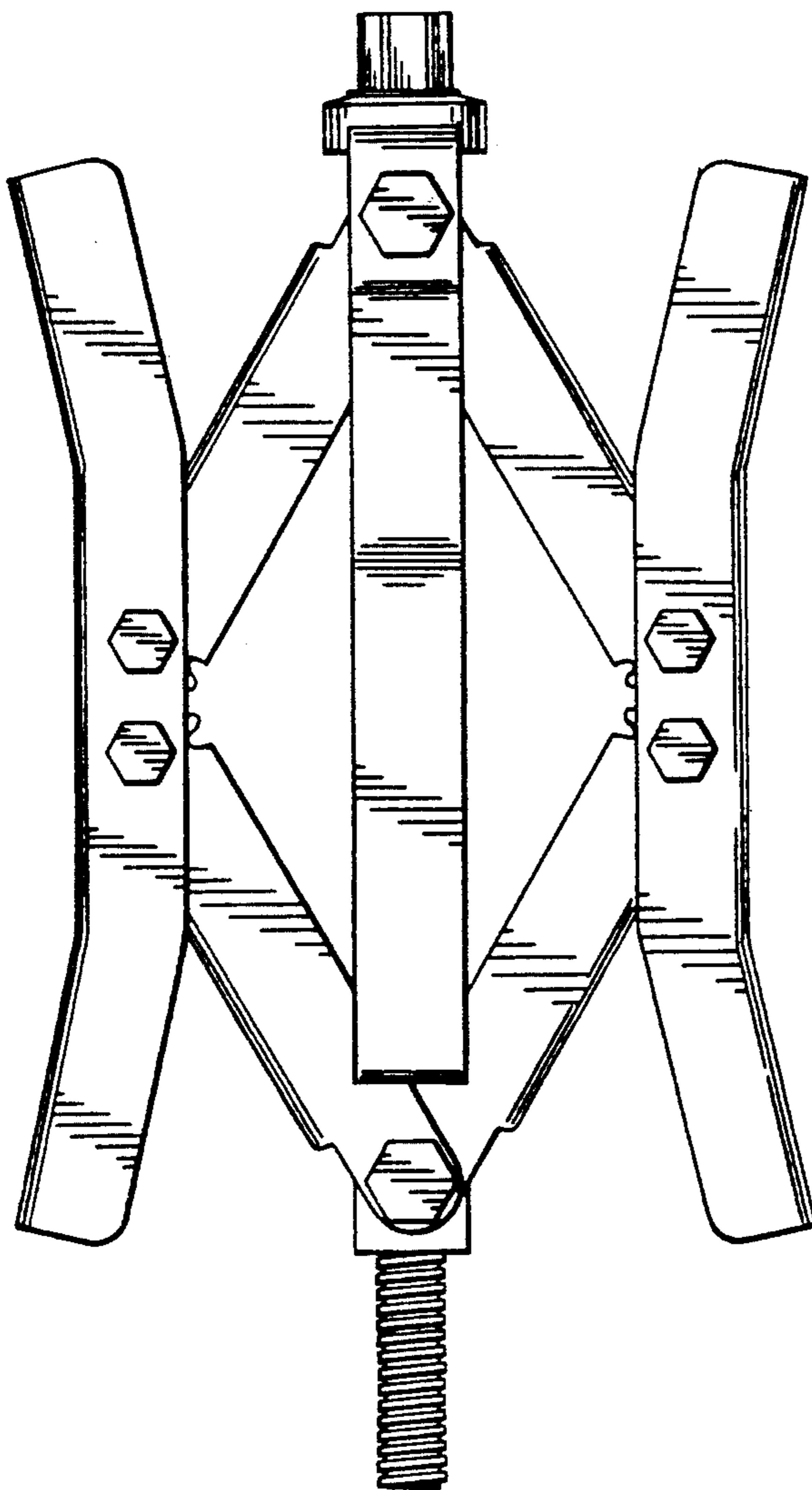

FIG. 3

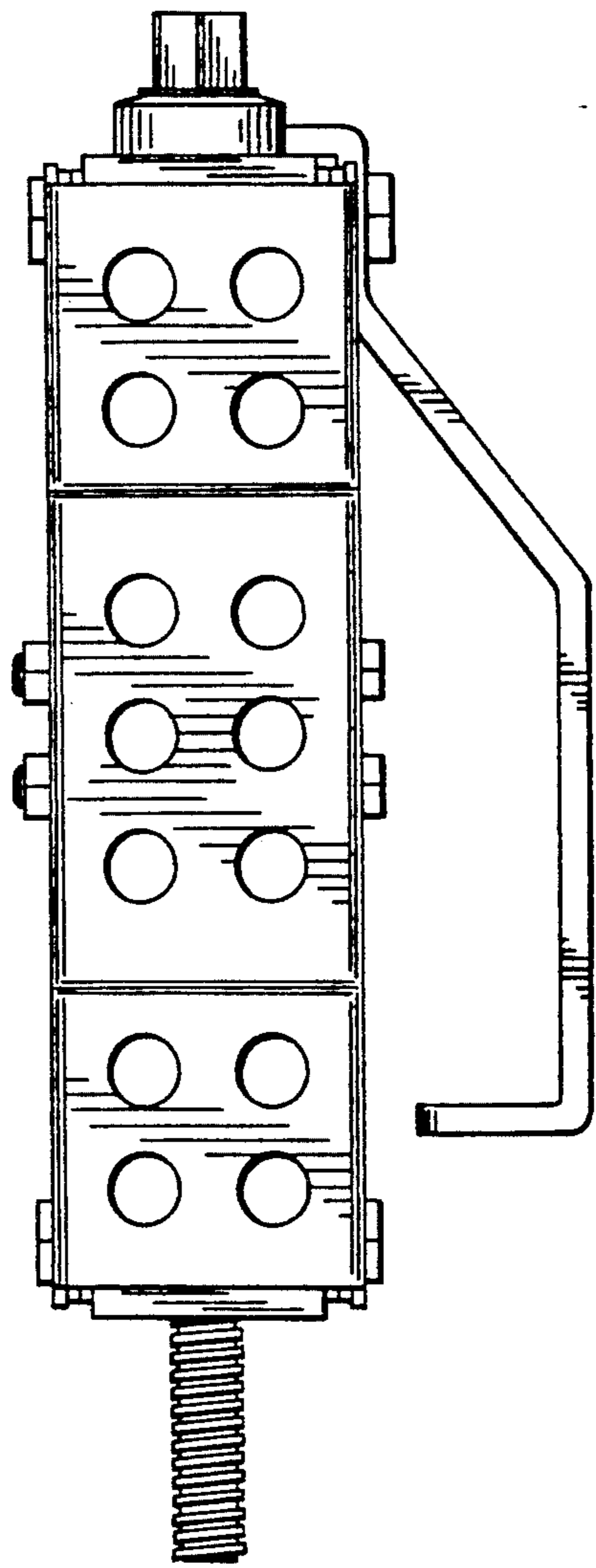

FIG. 4

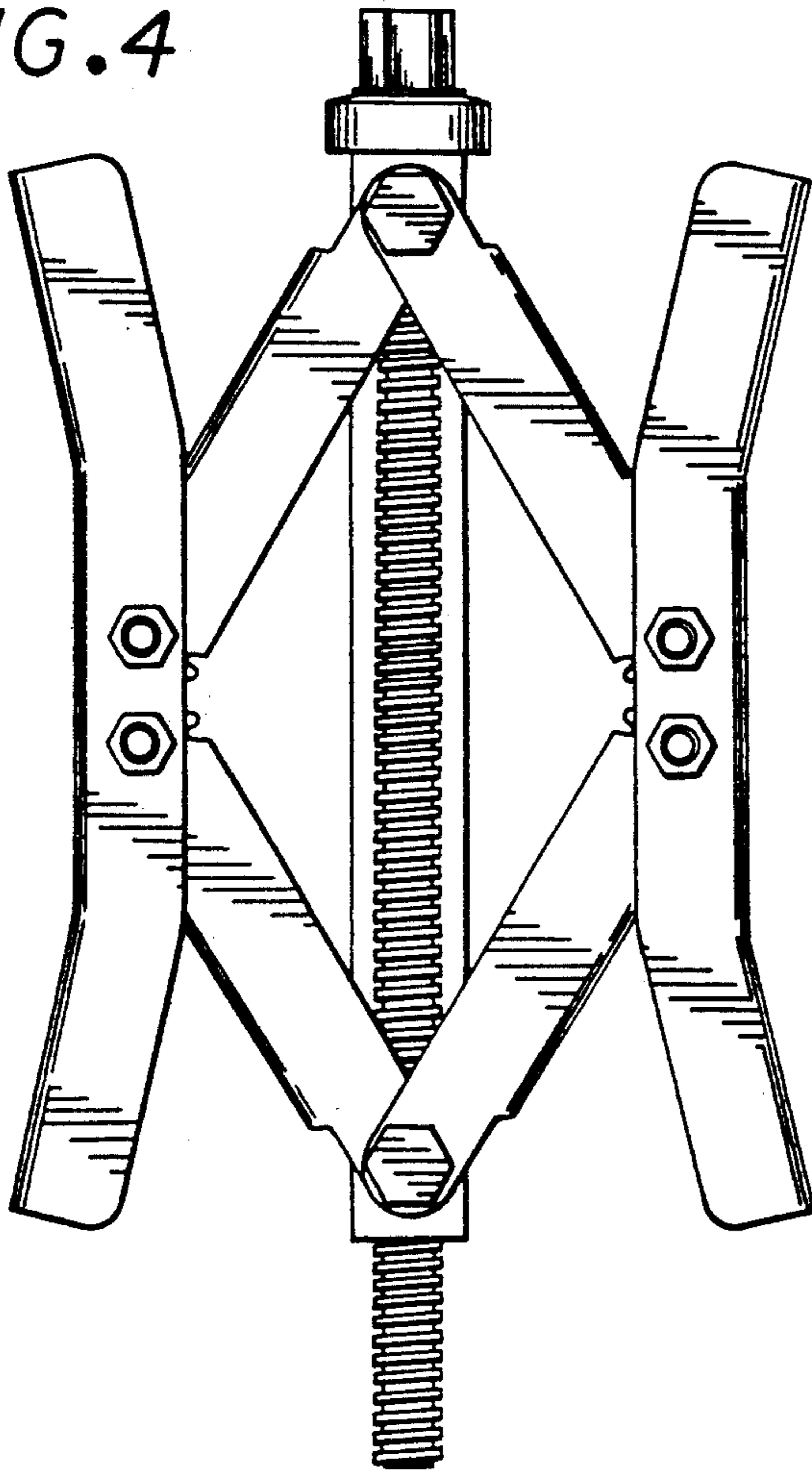

FIG. 5

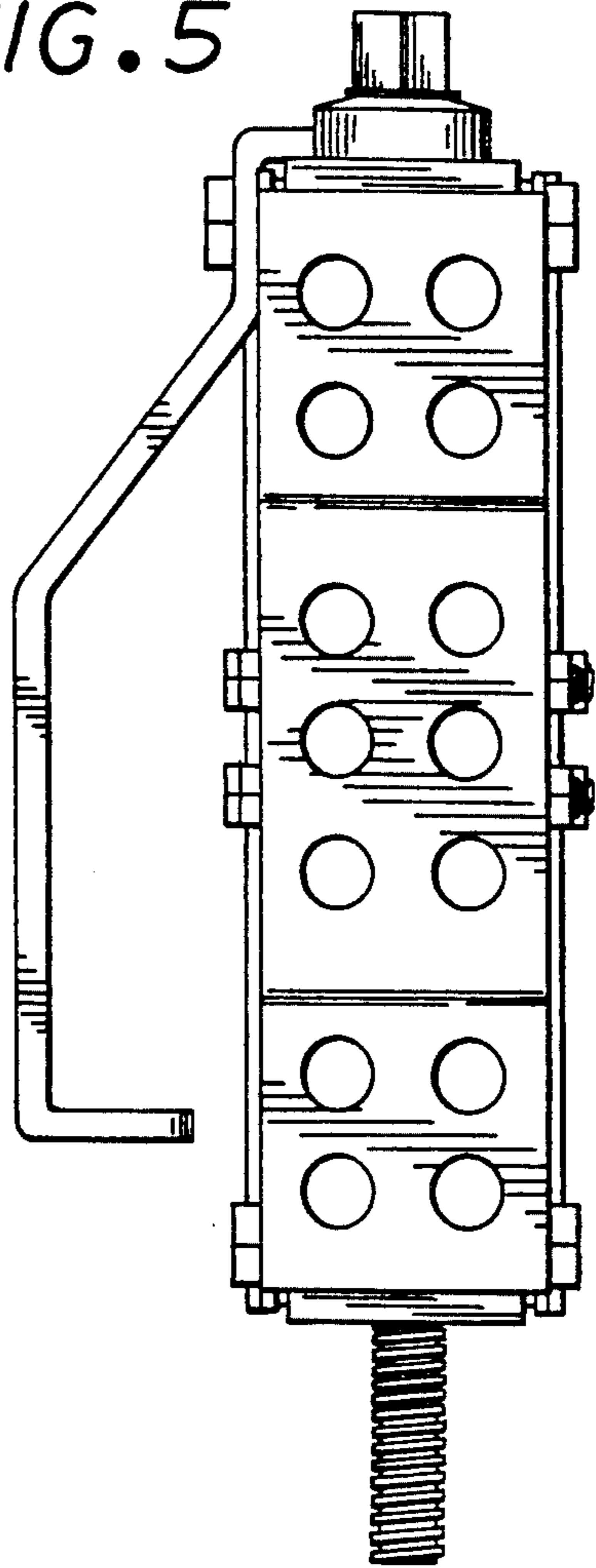

FIG. 6

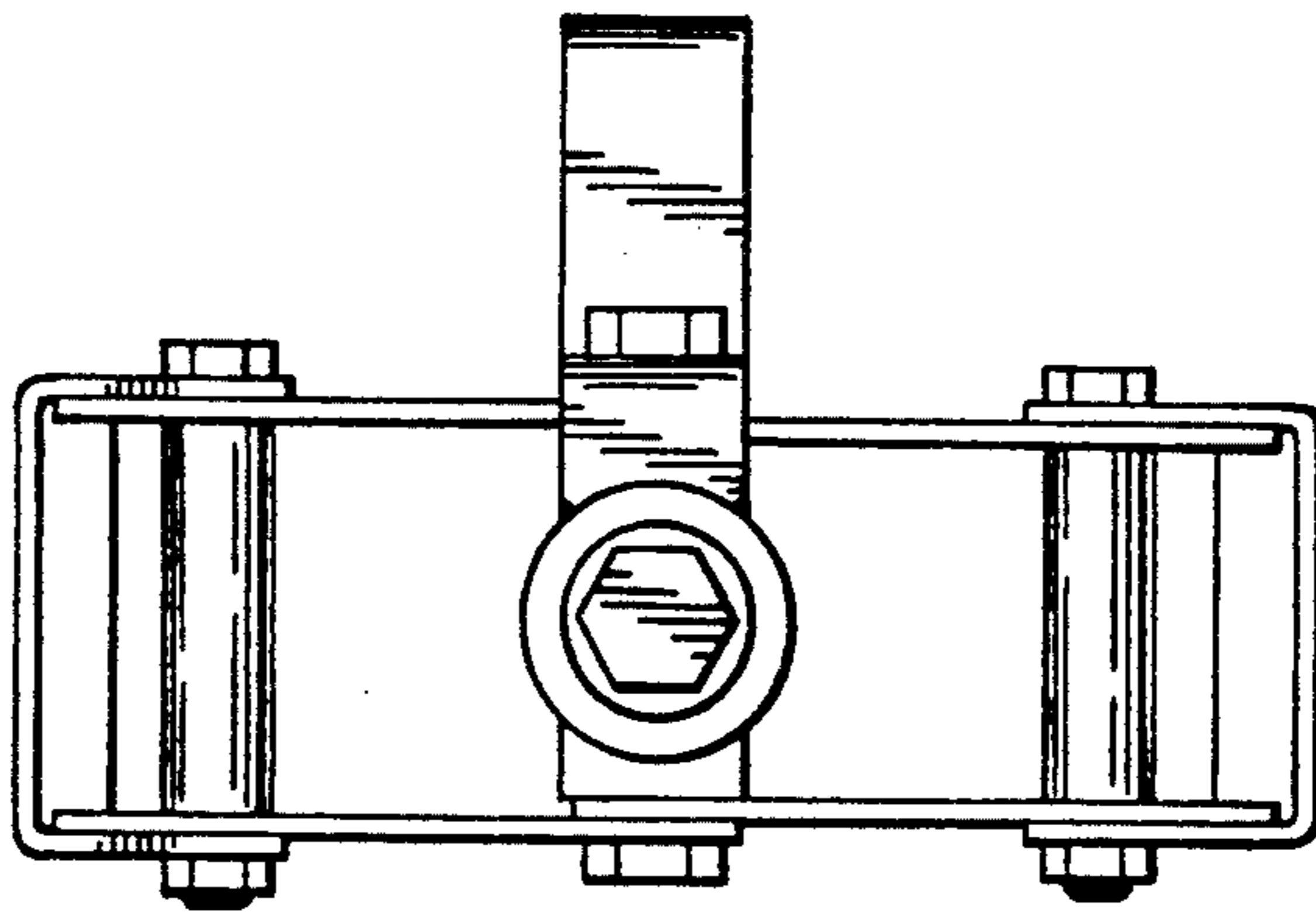

FIG. 7

