



US00D347808S

United States Patent [19]

Heinrich et al.

[11] Patent Number: **Des. 347,808**

[45] Date of Patent: **** Jun. 14, 1994**

[54] **MOTORCYCLE**

[75] Inventors: **Edgar Heinrich, Freising; Klaus V. Gevert, Munich, both of Fed. Rep. of Germany**

[73] Assignee: **Bayerische Motoren Werke AG, Munich, Fed. Rep. of Germany**

[**] Term: **14 Years**

[21] Appl. No.: **903,803**

[22] Filed: **Jun. 22, 1992**

[30] **Foreign Application Priority Data**

Dec. 20, 1991 [DE] Fed. Rep. of Germany 9109010

[52] U.S. Cl. **D12/110**

[58] Field of Search 280/219; D12/110

[56] **References Cited**

U.S. PATENT DOCUMENTS

D. 275,469 9/1981 Morioka et al. D12/110

D. 299,016	12/1988	Kitagawa et al.	D12/110
D. 299,447	1/1989	Sakuma	D12/110
D. 332,588	1/1993	Kohama et al.	D12/110
D. 333,641	3/1993	Sakaguchi et al.	D12/110
4,776,422	10/1988	Sakuma	296/78.1

Primary Examiner—Wallace R. Burke
Assistant Examiner—M. Brown
Attorney, Agent, or Firm—Evenson, McKeown, Edwards & Lenahan

[57] **CLAIM**

The ornamental design for a motorcycle, as shown.

DESCRIPTION

FIG. 1 is a front view of a motorcycle showing our new design;
FIG. 2 is a rear view thereof;
FIG. 3 is a right side view thereof;
FIG. 4 is a left side view thereof;
FIG. 5 is a left side perspective view thereof;
FIG. 6 is a right side perspective view thereof; and,
FIG. 7 is a top plan view thereof.

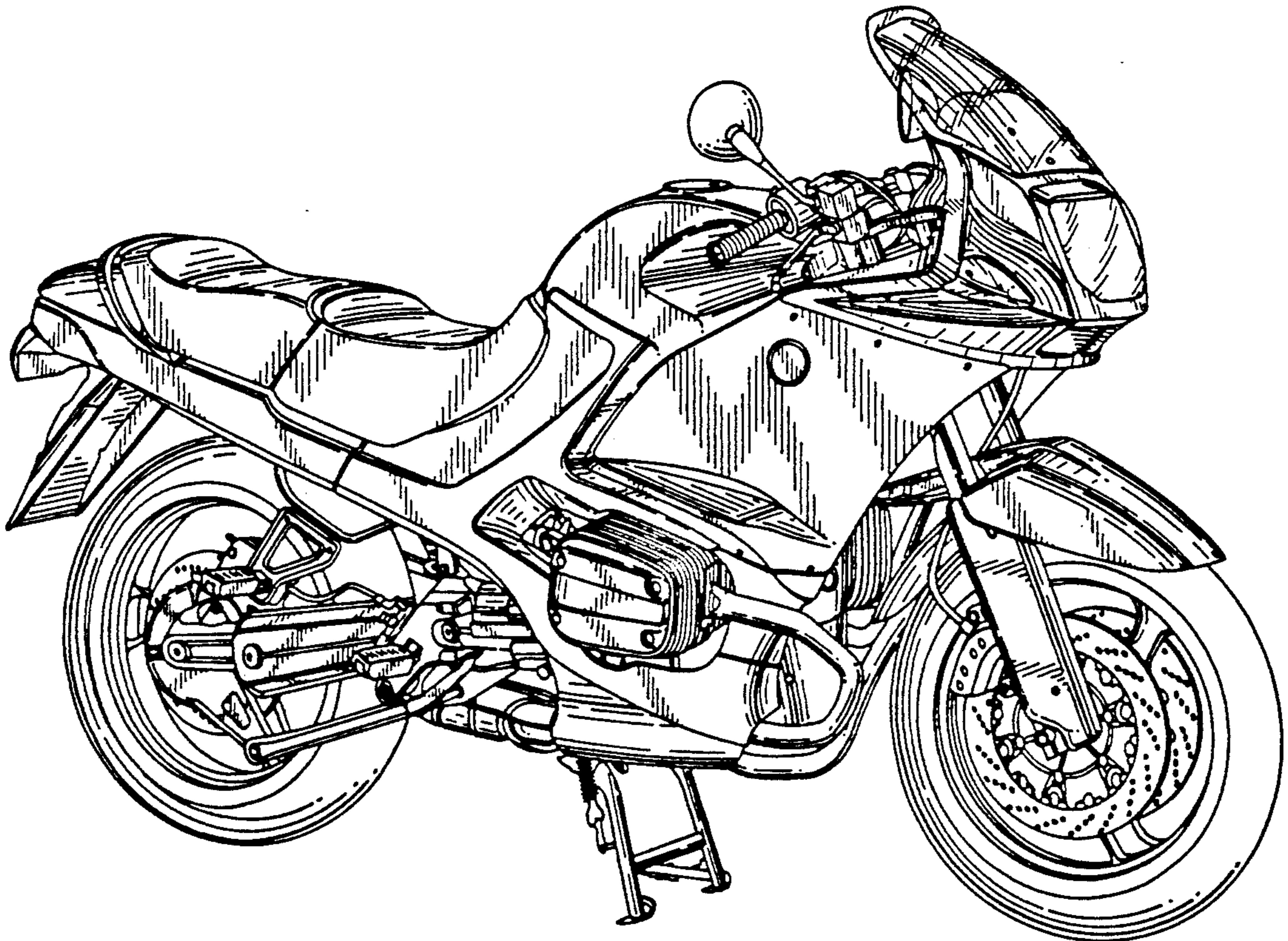

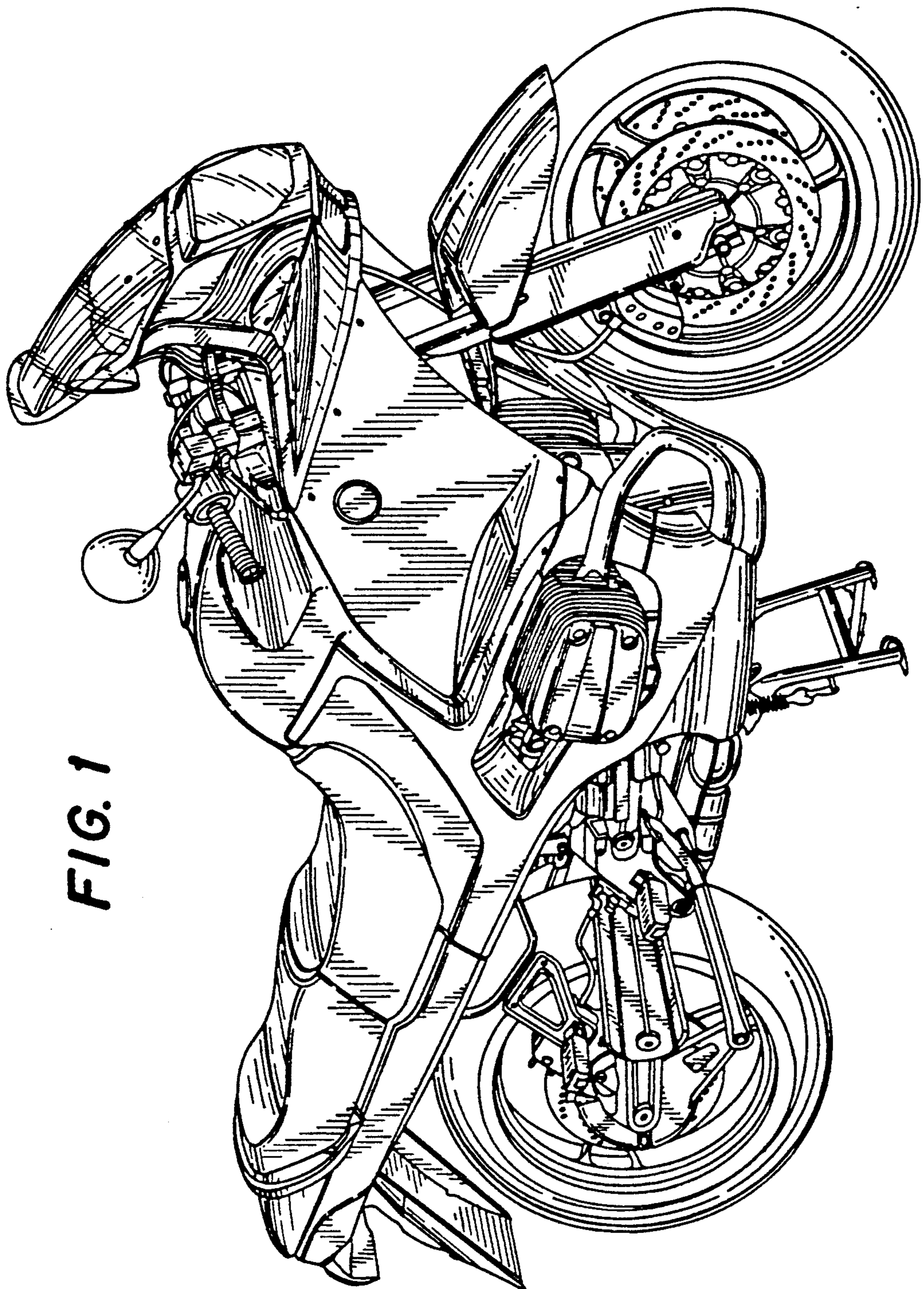

FIG. 1

FIG. 3

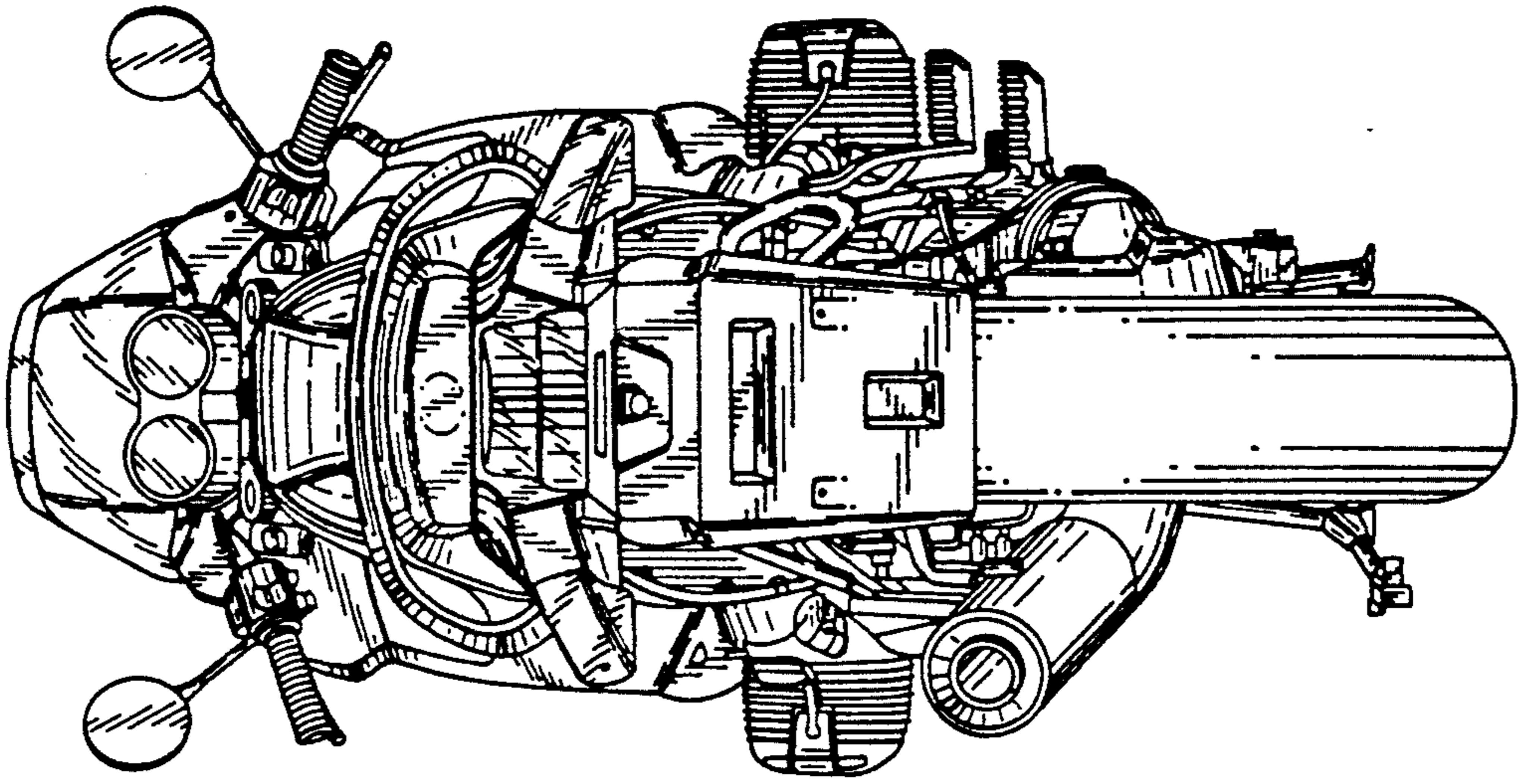
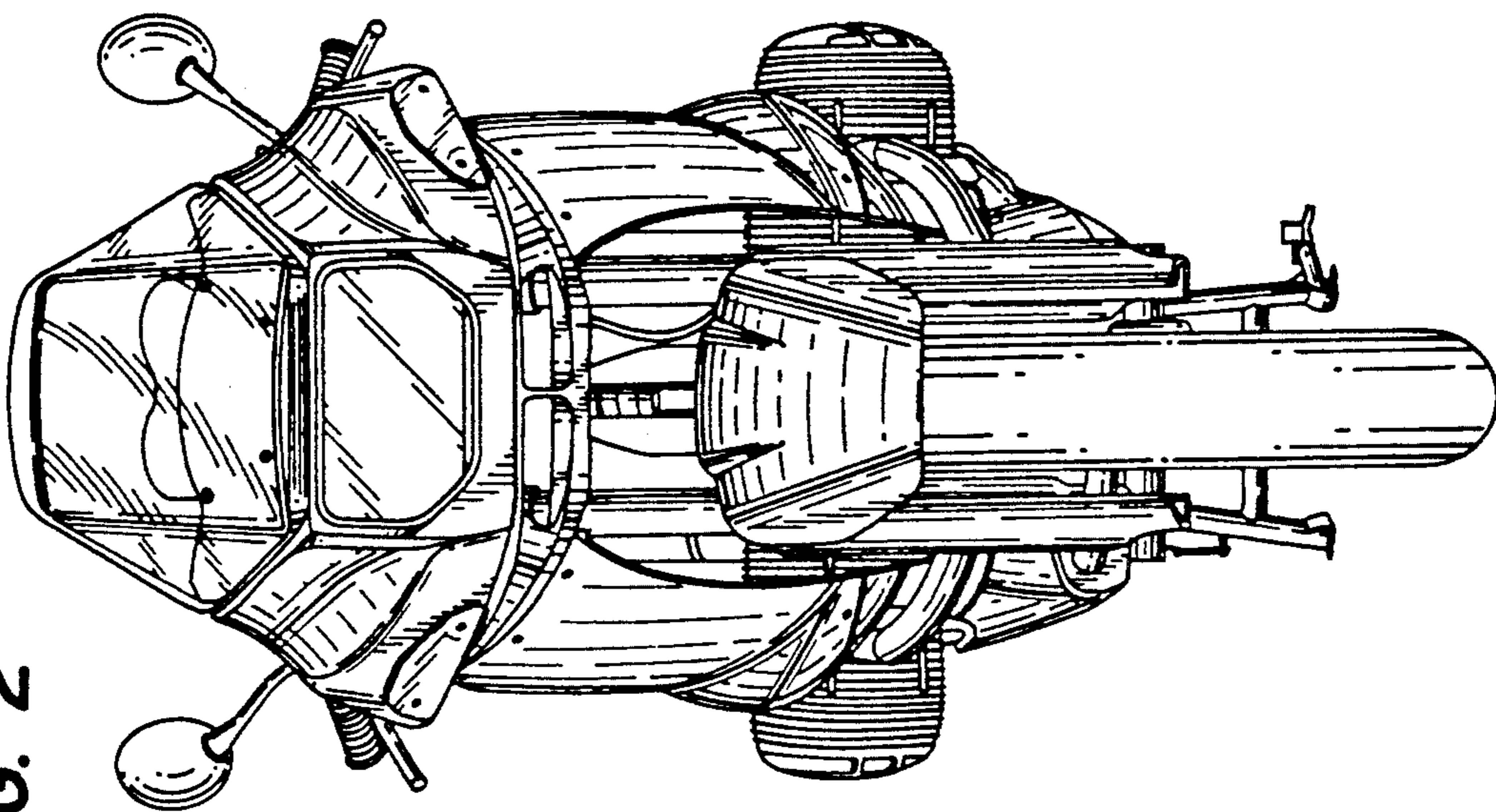

FIG. 2



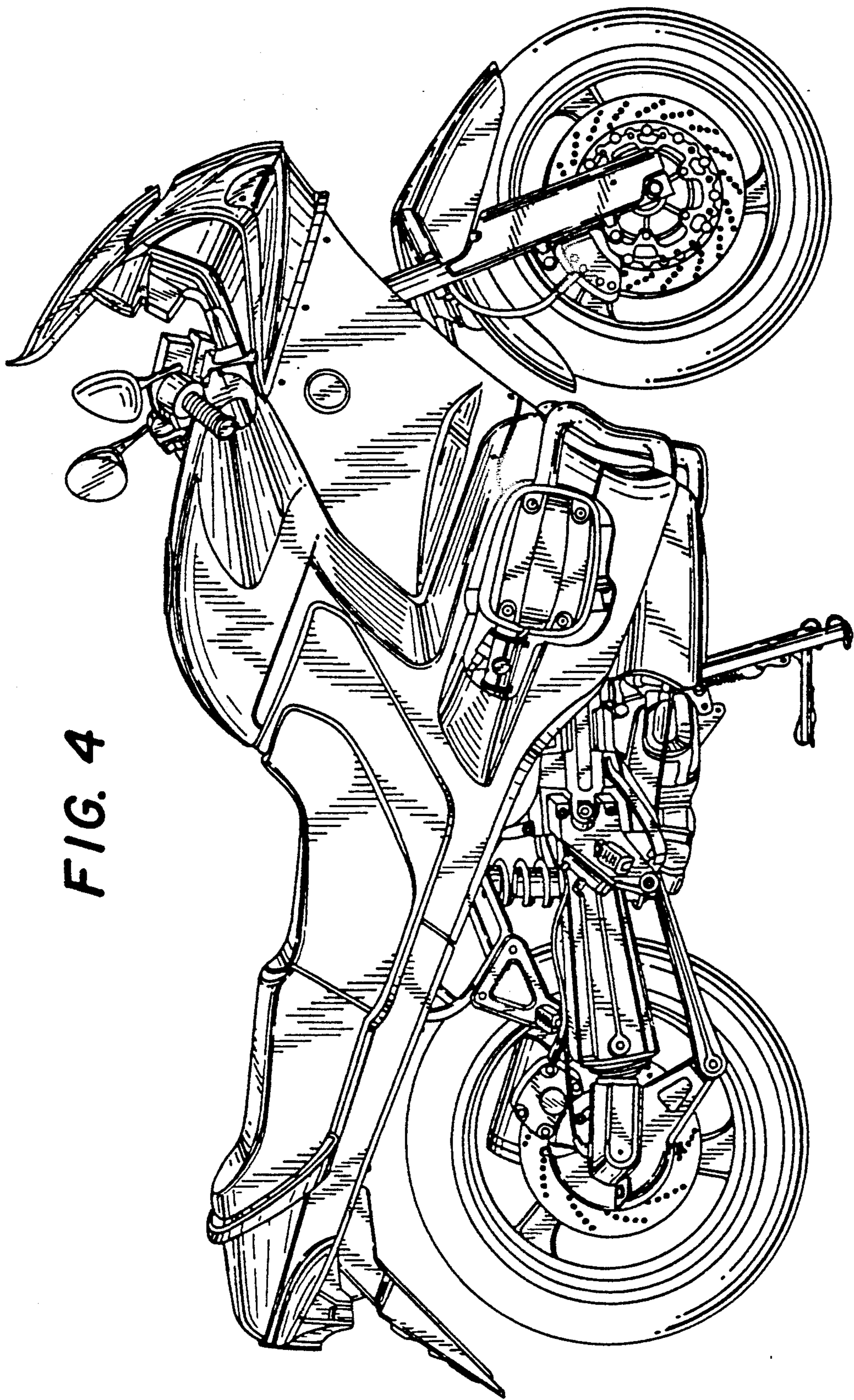

FIG. 4

