



US00D347805S

United States Patent [19]

Ueno et al.

[11] Patent Number: Des. 347,805

[45] Date of Patent: ** Jun. 14, 1994

[54] AUTOMOBILE

[75] Inventors: **Shigeo Ueno; Minoru Hayauchi**, both of Tokyo; **Hideyuki Ikeda**, Saitama, all of Japan

[73] Assignee: **Honda Giken Kogyo Kabushiki Kaisha**, Tokyo, Japan

[**] Term: **14 Years**

[21] Appl. No.: **910,971**

[22] Filed: **Jul. 6, 1992**

[52] U.S. Cl. **D12/92**

[58] Field of Search **296/185; D12/91, 92**

[56] References Cited

U.S. PATENT DOCUMENTS

D. 301,848 6/1989 Kurosu et al. **D12/92**

OTHER PUBLICATIONS

1992 Hyundai Brochure, ©1991, p. 1&2, Hyundai Sonata Automobile.

Road & Track, Sep. 1991, p. 96, Hyundai Elantra, top of page.

Road & Track, Oct. 1990, p. 107, Infiniti Automobile, bottom of page.

Road & Track, Dec. 1991, p. 50, Ford Sierra Automobile, third photograph down from top right side of page.

Primary Examiner—James M. Gandy

Attorney, Agent, or Firm—Lyon & Lyon

[57] CLAIM

The ornamental design for an automobile, as shown and described.

DESCRIPTION

FIG. 1 is a left side elevation view of an automobile showing our new design and the right side elevation view is a mirror image thereof;

FIG. 2 is a top plan view thereof;

FIG. 3 is a front elevation view thereof; and,

FIG. 4 is a rear elevation view thereof.

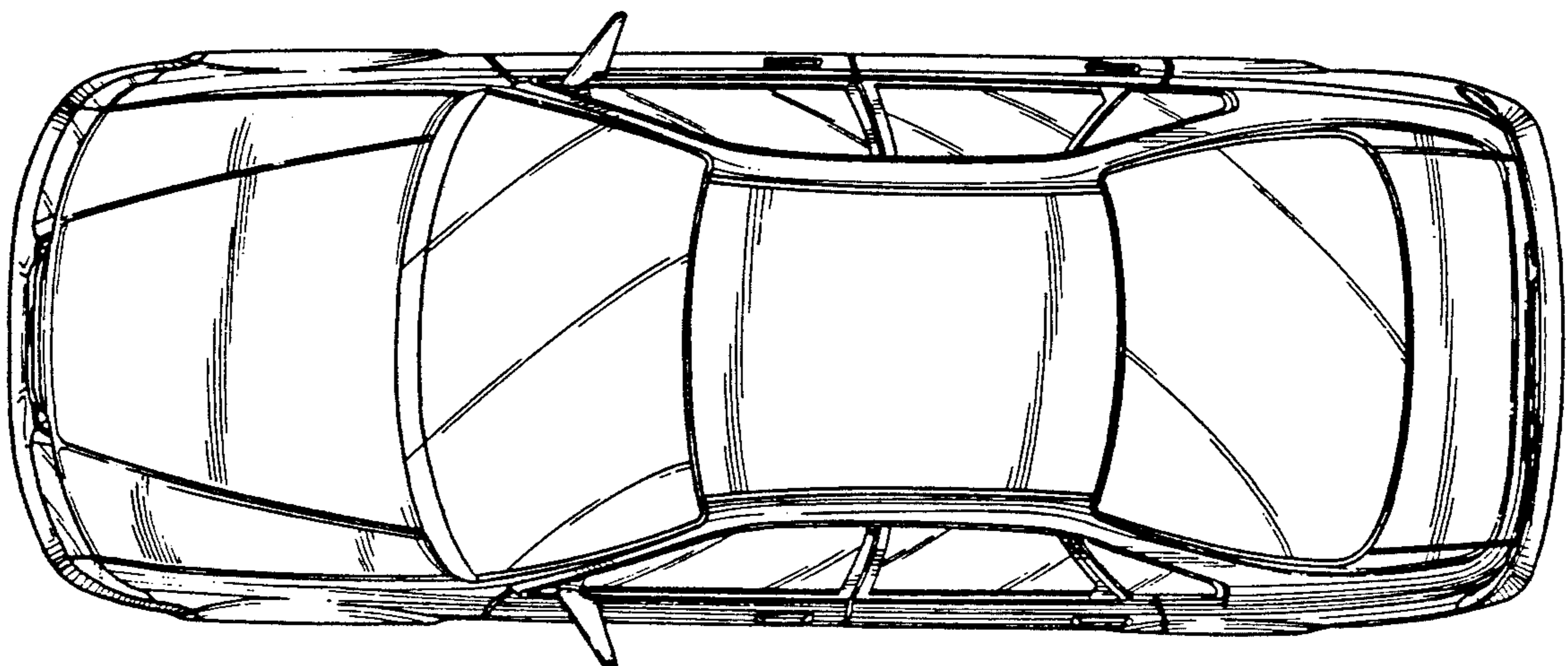
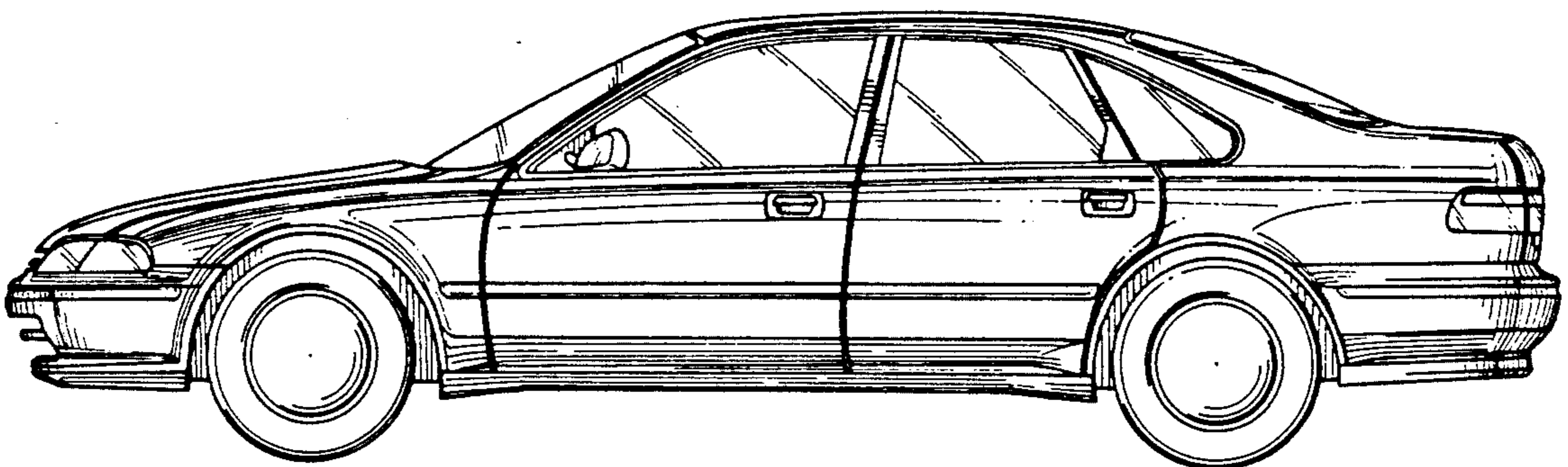

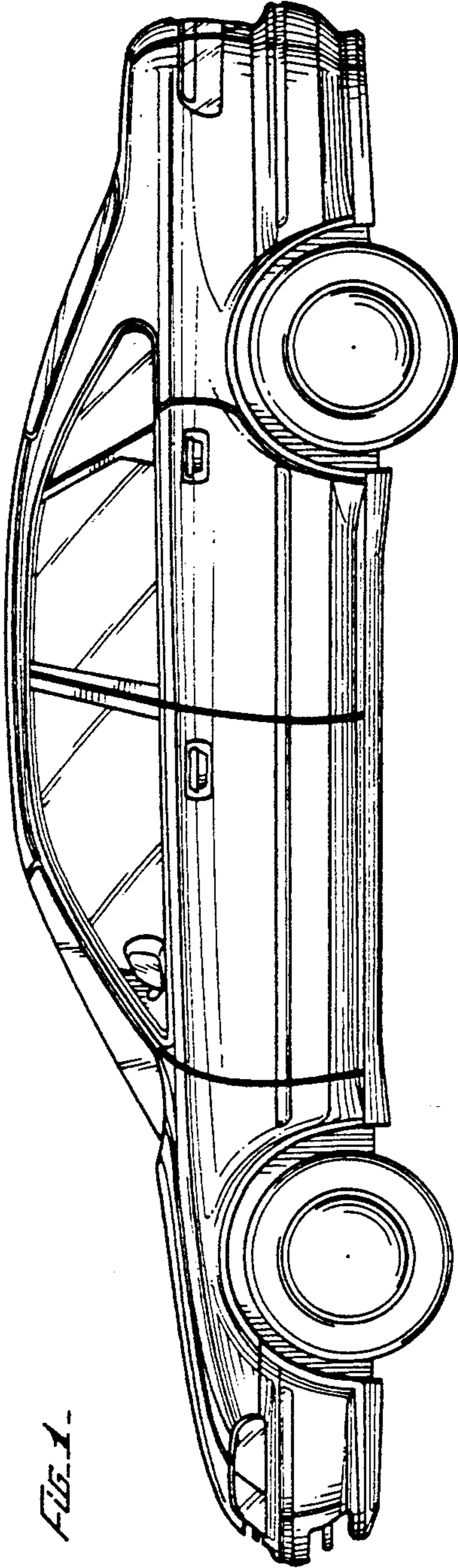

FIG. 1.

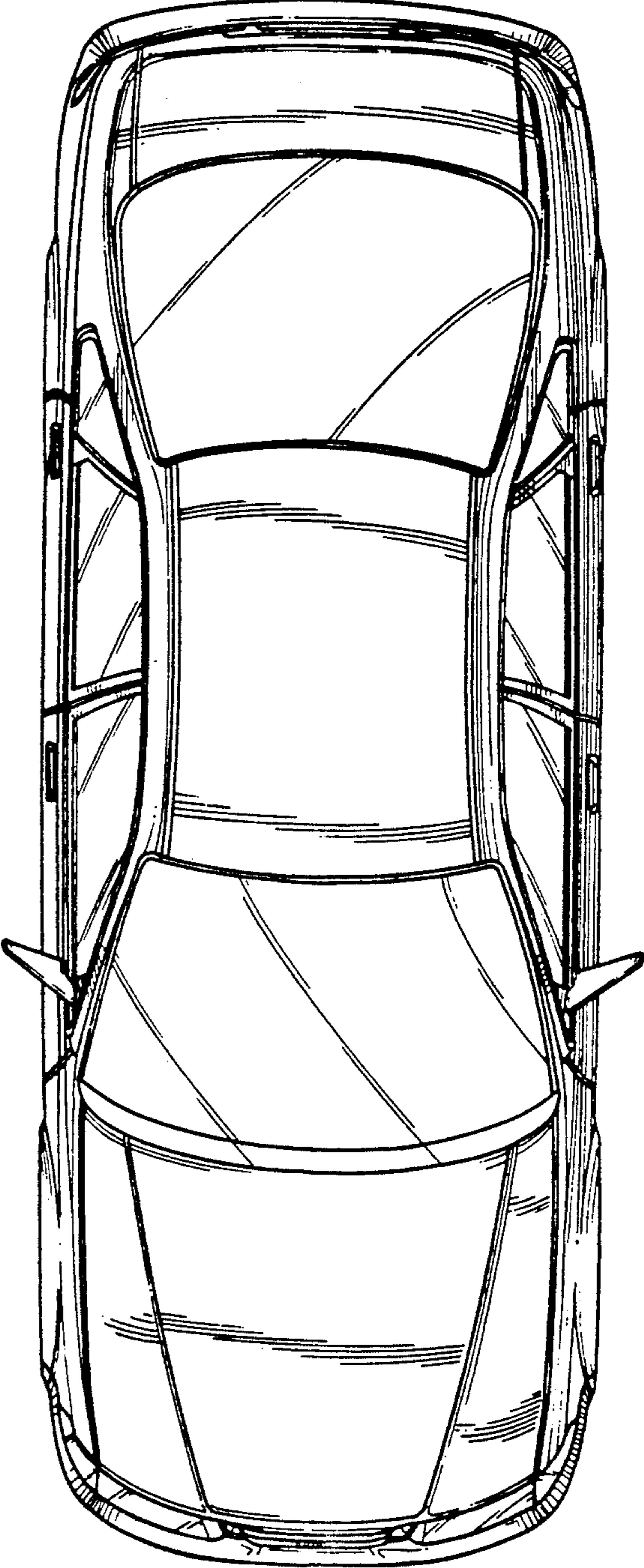

FIG. 2.

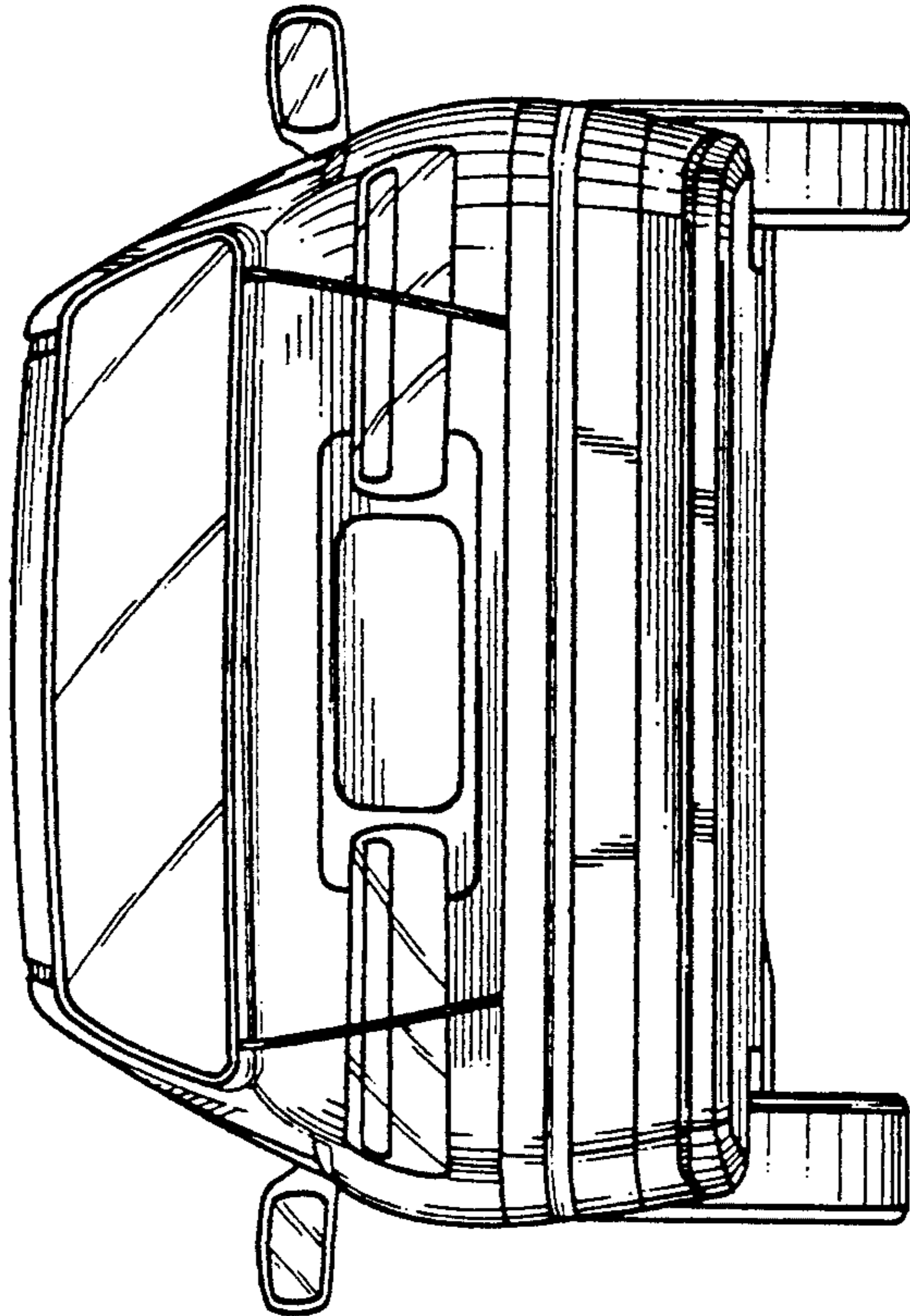

FIG. 1.

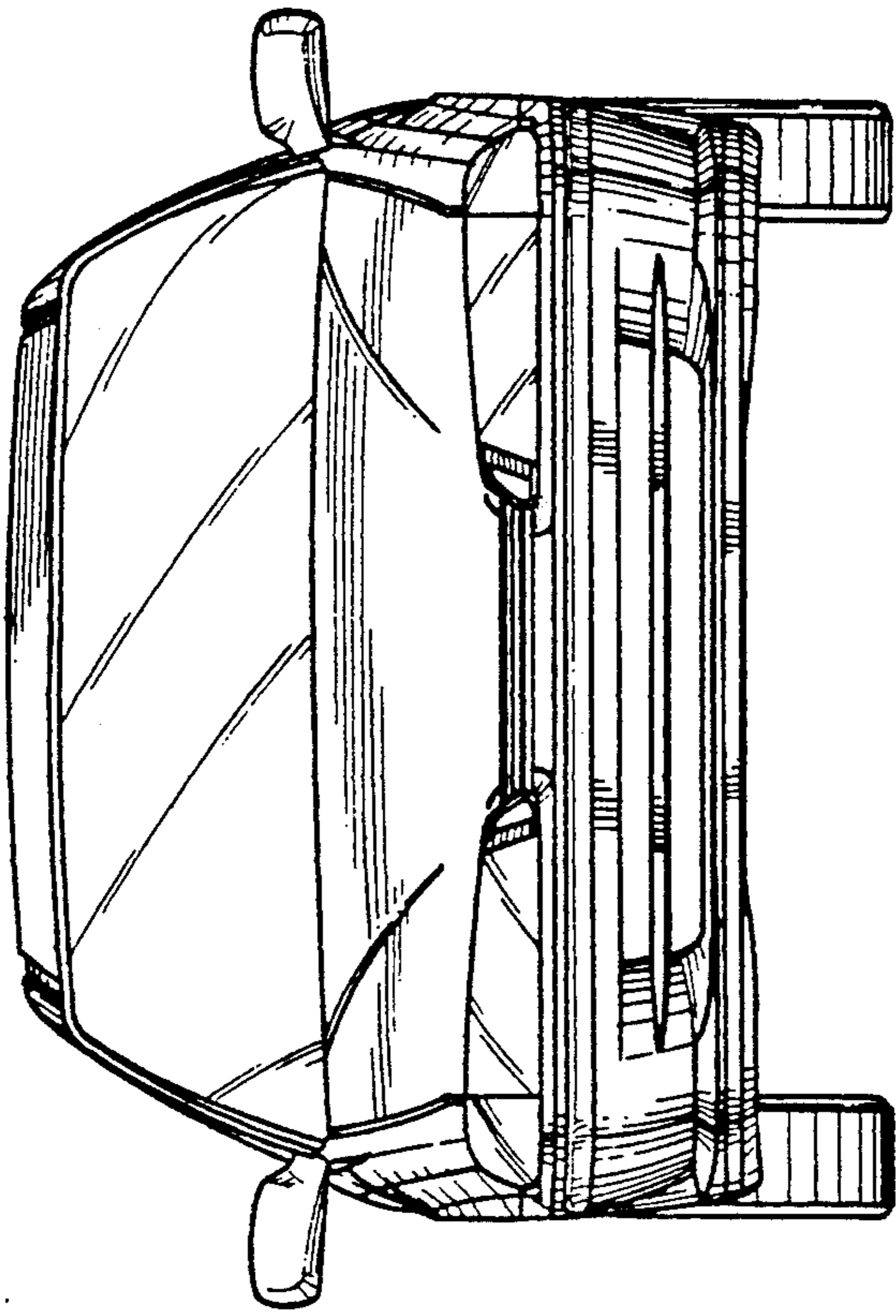

FIG. 2.