



US00D347467S

United States Patent [19]

[11] Patent Number: **Des. 347,467**

Medvick

[45] Date of Patent: **** May 31, 1994**

[54] **SLEEVE FOR A QUICK CONNECT FLUID COUPLING**

[75] Inventor: **Richard J. Medvick, Shaker Heights, Ohio**

[73] Assignee: **Swagelok Quick-Connect Co., Hudson, Ohio**

[*] Notice: The portion of the term of this patent subsequent to Jan. 31, 2006 has been disclaimed.

[**] Term: **14 Years**

[21] Appl. No.: **239,419**

[22] Filed: **Sep. 1, 1988**

[52] U.S. Cl. **D23/262**

[58] Field of Search 285/39, 177, 179, 369, 285/370, 38, 315, 8, 316, 235, 292, 293, 294, 232, 233; 403/221, 223, 300, 309; 251/149.6; 137/614.04; D23/260-265

[56] **References Cited**

U.S. PATENT DOCUMENTS

D. 227,763	7/1973	Hand	D23/262
D. 234,847	4/1975	Hoffman	D23/262
D. 254,802	4/1980	Hayes	D23/262
D. 267,506	1/1983	Evans	D23/262
D. 299,267	1/1989	Roman	D23/262
2,479,058	4/1949	Botting	205/232
2,529,552	11/1950	Herold	285/232
2,853,319	9/1958	Press	285/39

3,113,588	12/1963	Torres	285/316 X
3,337,244	8/1967	Appleberry	285/316 X
3,439,943	4/1969	Thomsen	285/316
3,784,239	1/1974	Carter et al.	285/293
4,098,292	7/1978	Evans	137/614.04
4,114,853	9/1978	Medrick	285/316 X
4,198,080	4/1980	Carpenter	285/316 X
4,366,945	1/1983	Blauenstein	285/316 X
4,543,993	10/1985	Calvin et al.	285/316 X
4,582,347	4/1986	Wilcox et al.	285/316 X
4,729,583	3/1988	Lalikos et al.	285/903
4,792,162	12/1988	Medvick	285/316 X

Primary Examiner—James R. Largen
Attorney, Agent, or Firm—Fay, Sharpe, Beall, Fagan, Minnich & McKee

[57] CLAIM

The ornamental design sleeve for a quick connect fluid coupling, as shown.

DESCRIPTION

FIG. 1 is a side elevational view of a sleeve for a quick connect fluid coupling showing my new design, the other sides being the same as the side shown; FIG. 2 is a left end elevational view thereof; FIG. 3 is a right end elevational view thereof; FIG. 4 is a perspective view taken from the side and right end thereof; and, FIG. 5 is another side elevational view thereof. The broken line representation of a quick connect fluid coupling in FIG. 5 is for purposes of illustration only and forms no part of the claimed design.

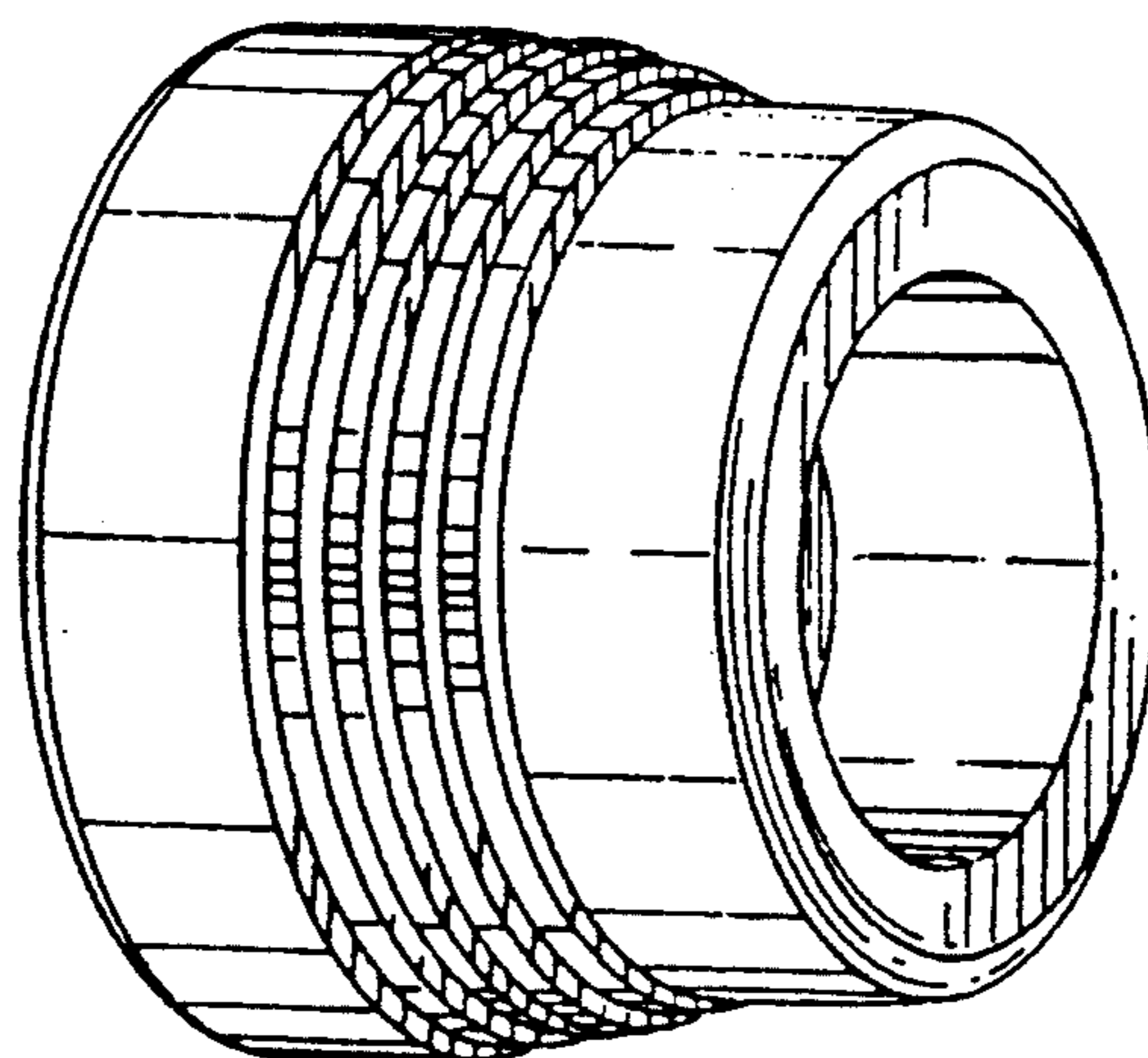

FIG. 4

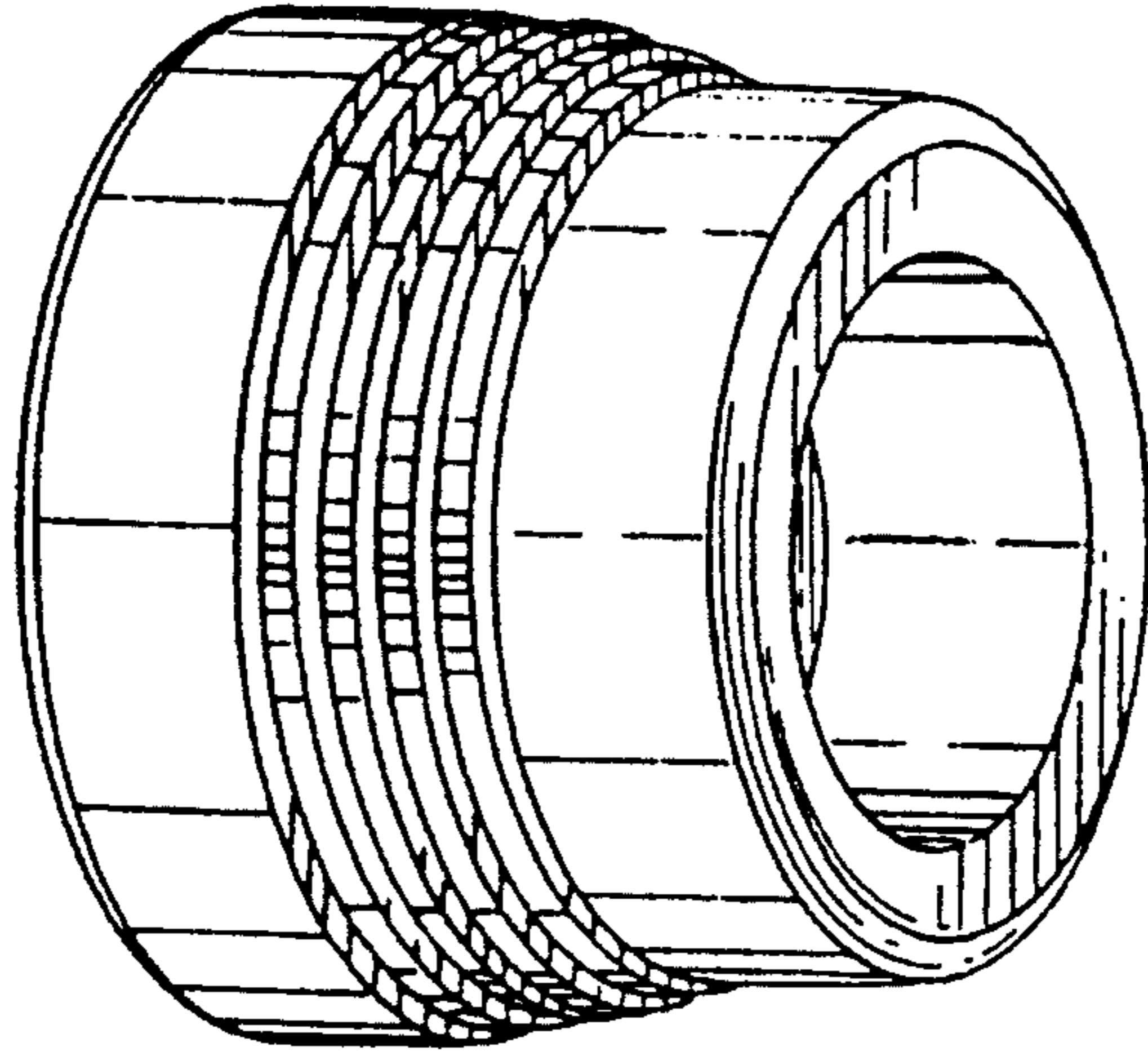

FIG. 1

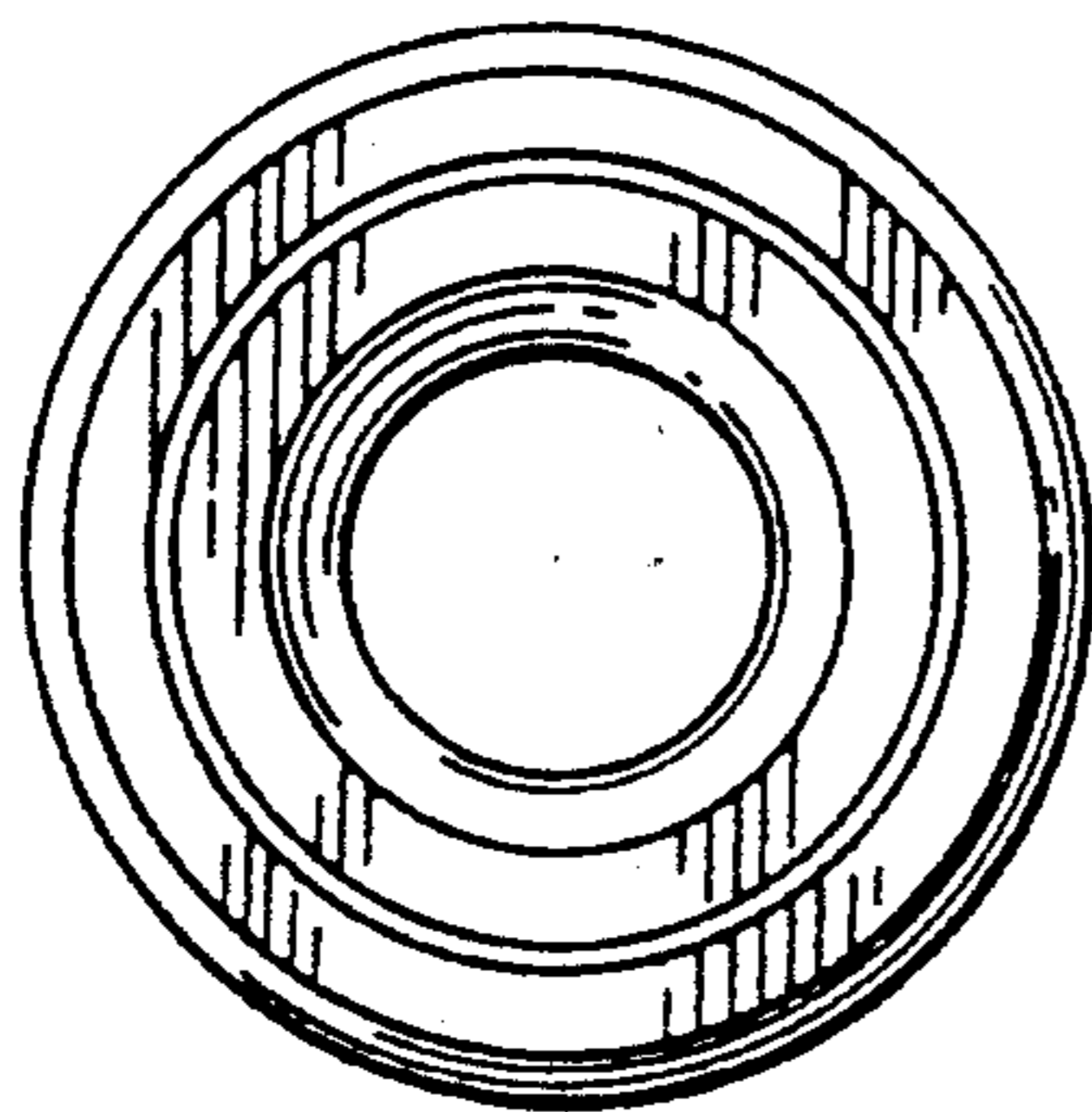
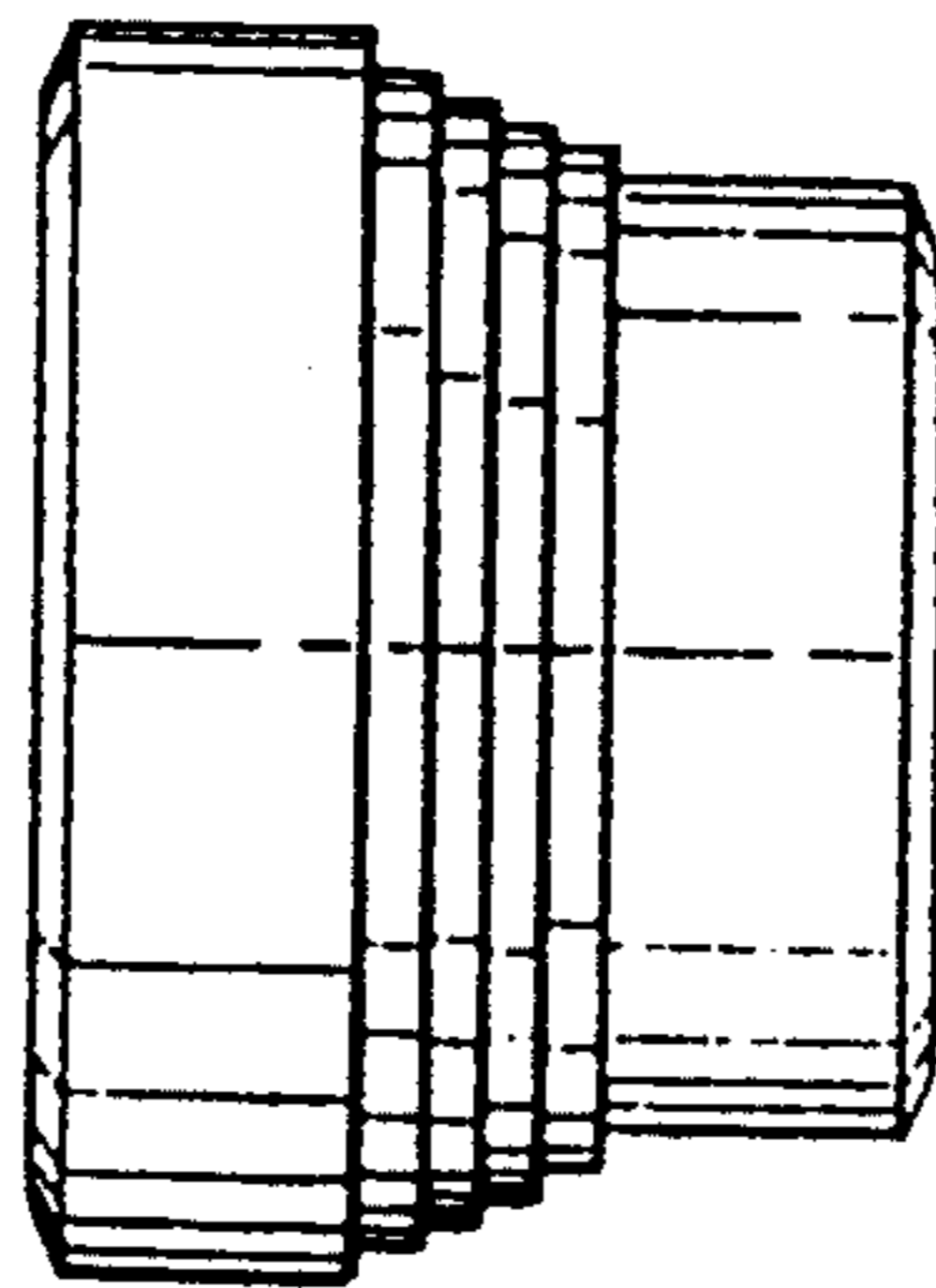

FIG. 2

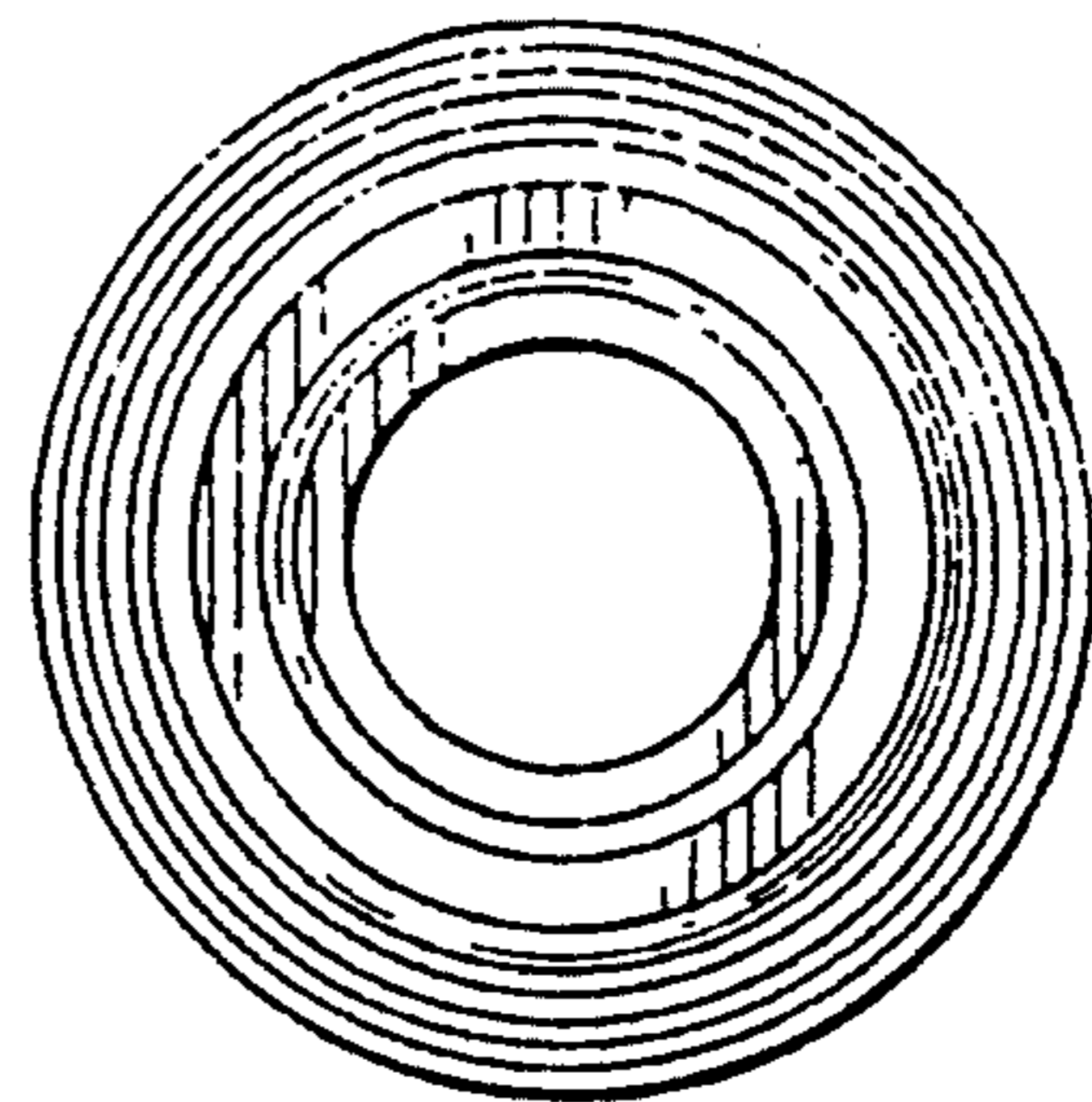

FIG. 3

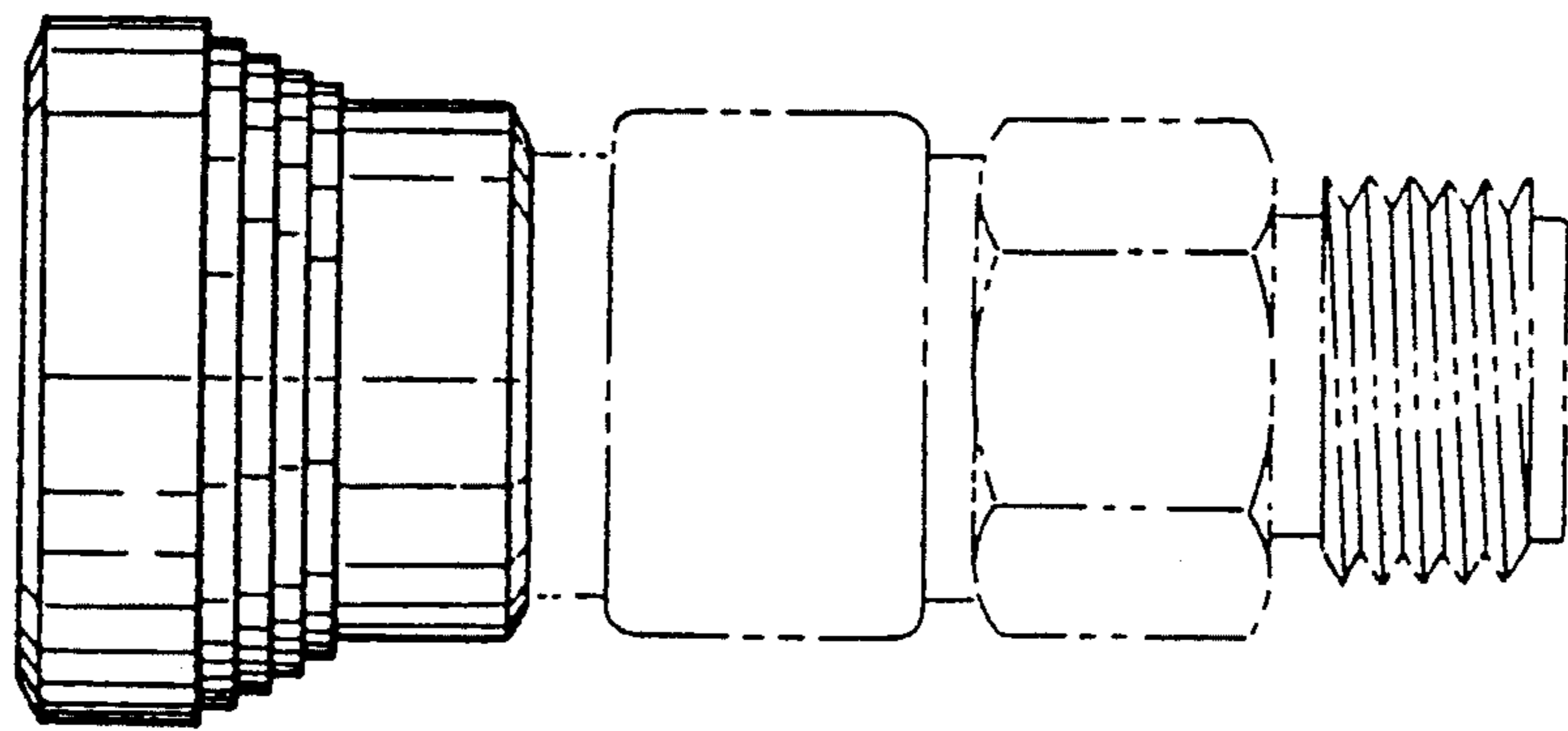

FIG. 5