



US00D347415S

United States Patent [19]

[11] Patent Number: **Des. 347,415**

Rossigno et al.

[45] Date of Patent: **** May 31, 1994**

[54] **FRONT PARTITION FOR A TANDEM BRAKE BOOSTER**

4,447,897	5/1984	Boehm	91/369.4
4,598,625	7/1986	Belart	91/369.3
5,076,142	12/1991	Steer et al.	91/369.3

[75] Inventors: **Louis P. Rossigno, Granger, Ind.; Jon R. Dodson, Niles, Mich.; Thomas E. Dodd, South Bend, Ind.; Thomas M. O'Brien, Buchanan, Mich.; John E. Steer, South Bend, Ind.**

Primary Examiner—Wallace R. Burke
Assistant Examiner—M. Brown
Attorney, Agent, or Firm—Leo H. McCormick, Jr.; Ken C. Decker

[73] Assignee: **Allied-Signal Inc., Morristown, N.J.**

[57] **CLAIM**

[**] Term: **14 Years**

The ornamental design for a front partition for a tandem brake booster, as shown and described.

[21] Appl. No.: **994,186**

DESCRIPTION

[22] Filed: **Dec. 21, 1992**

[52] U.S. Cl. **D12/180**

[58] Field of Search 91/369.1, 369.2, 369.3, 91/369.4; D12/180

FIG. 1 is a front elevation view of a front partition for a tandem brake booster showing our new design; FIG. 2 is a side elevation view thereof, the opposite side being a mirror image of that shown; FIG. 3 is a rear elevation view thereof; FIG. 4 is a front perspective view of the partition plate of FIG. 1; and, FIG. 5 is a rear perspective view thereof.

[56] **References Cited**

U.S. PATENT DOCUMENTS

4,348,944 9/1982 Ochiai 91/369.3

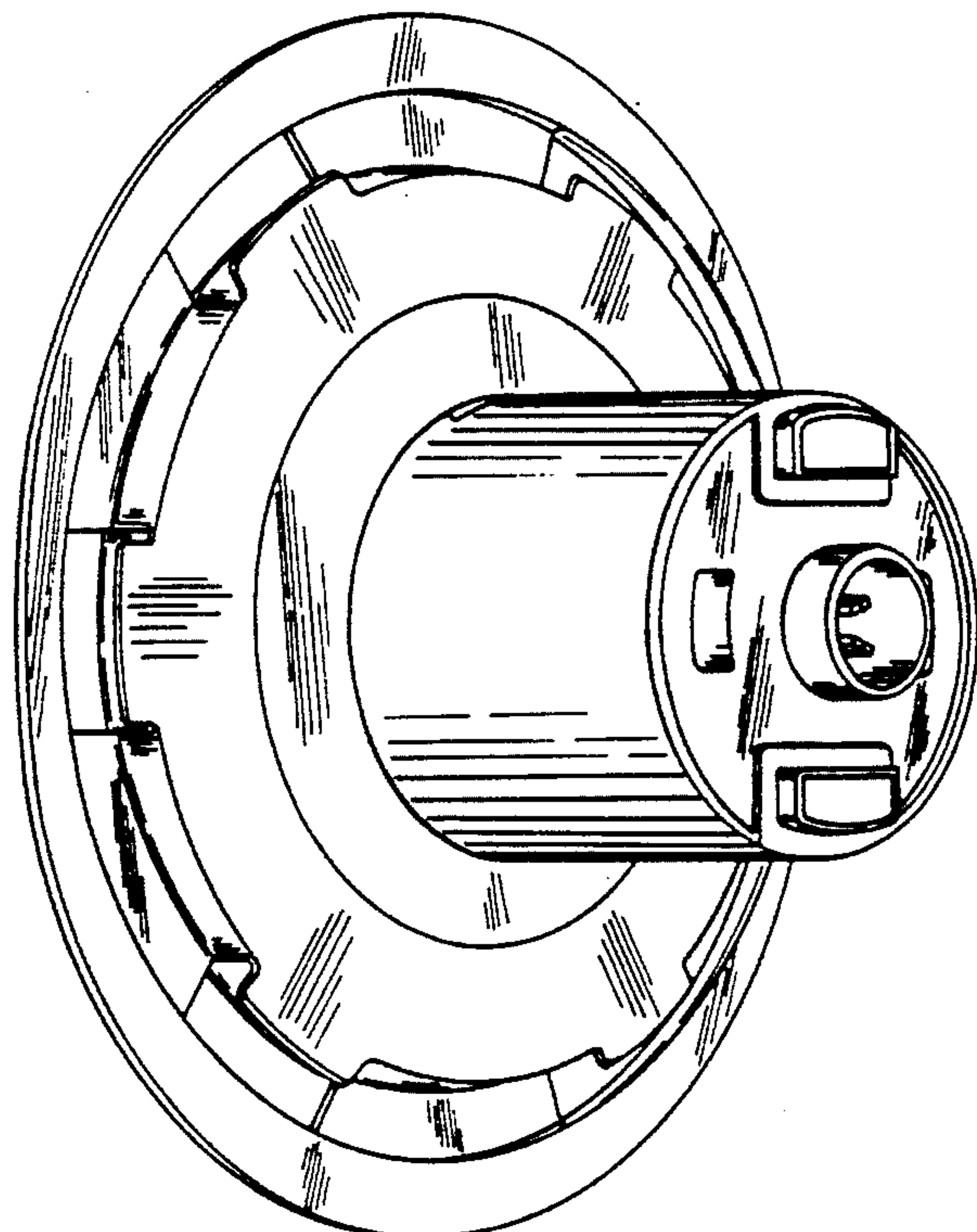
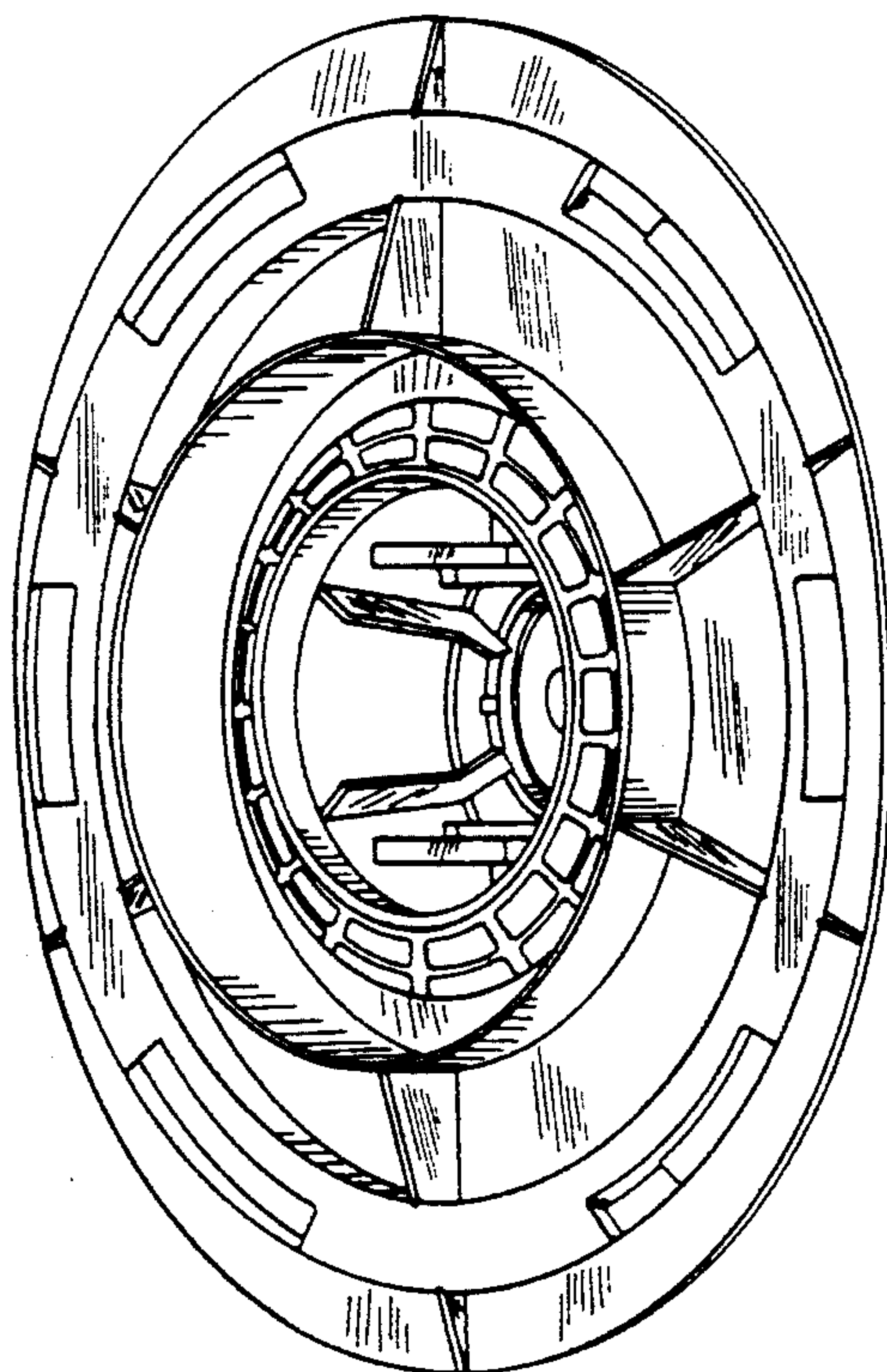

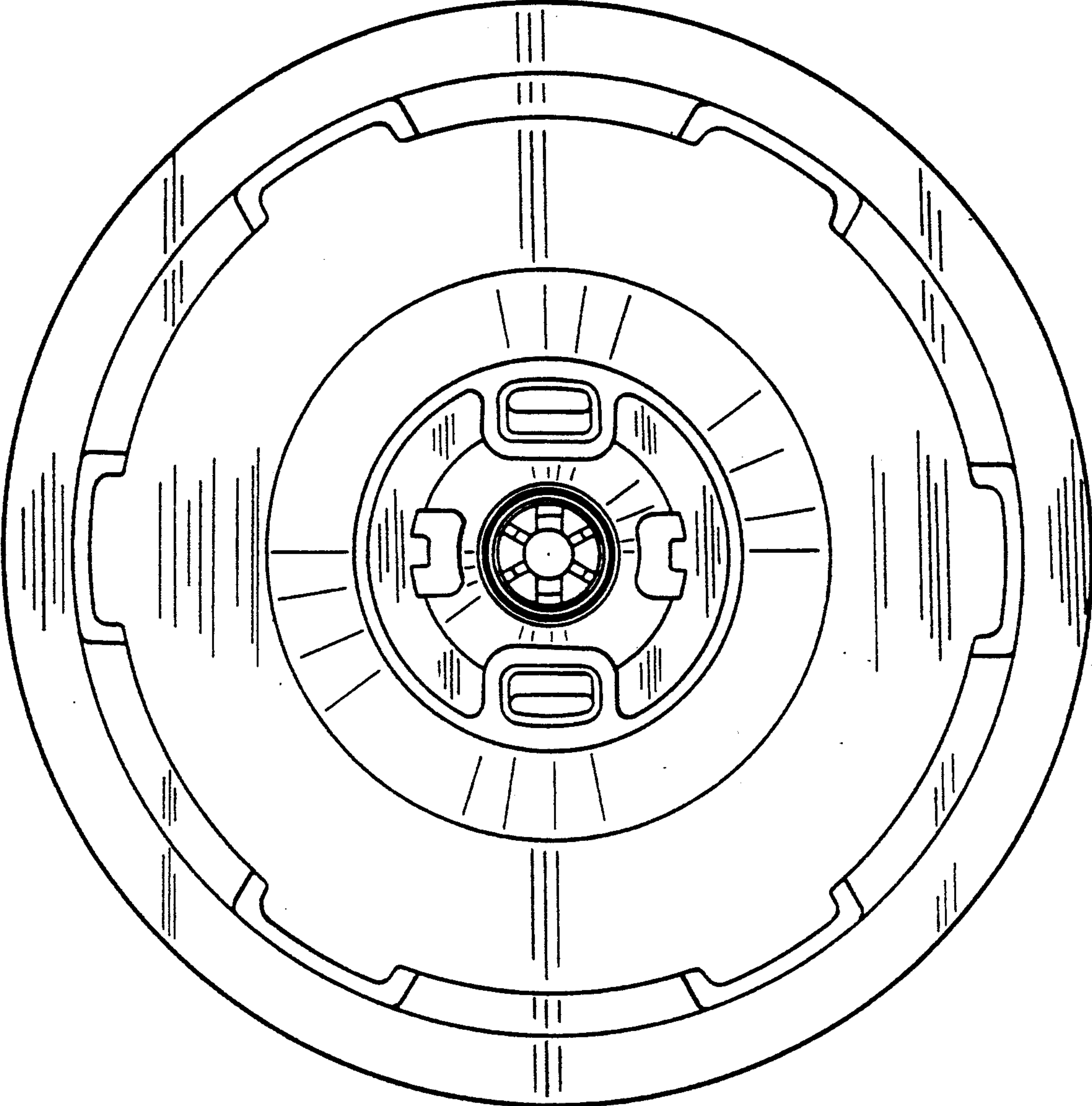

FIG. 1

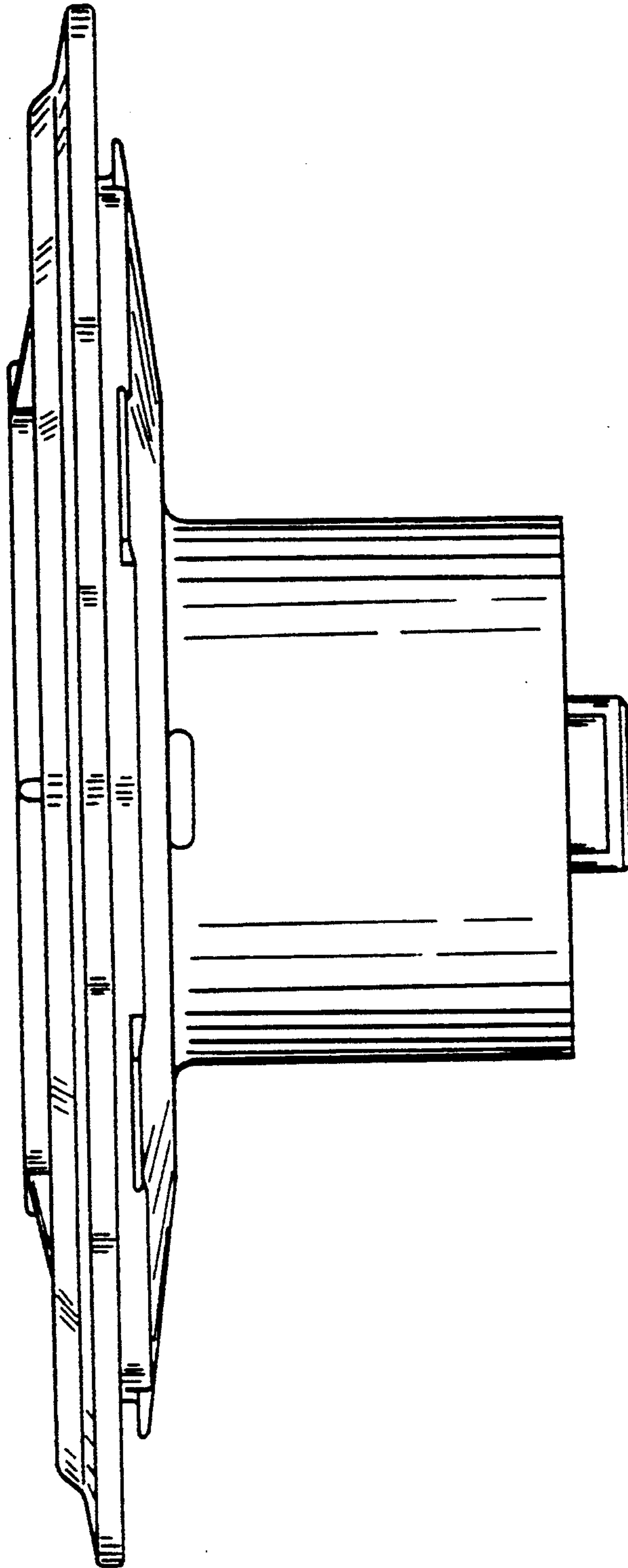

FIG. 2

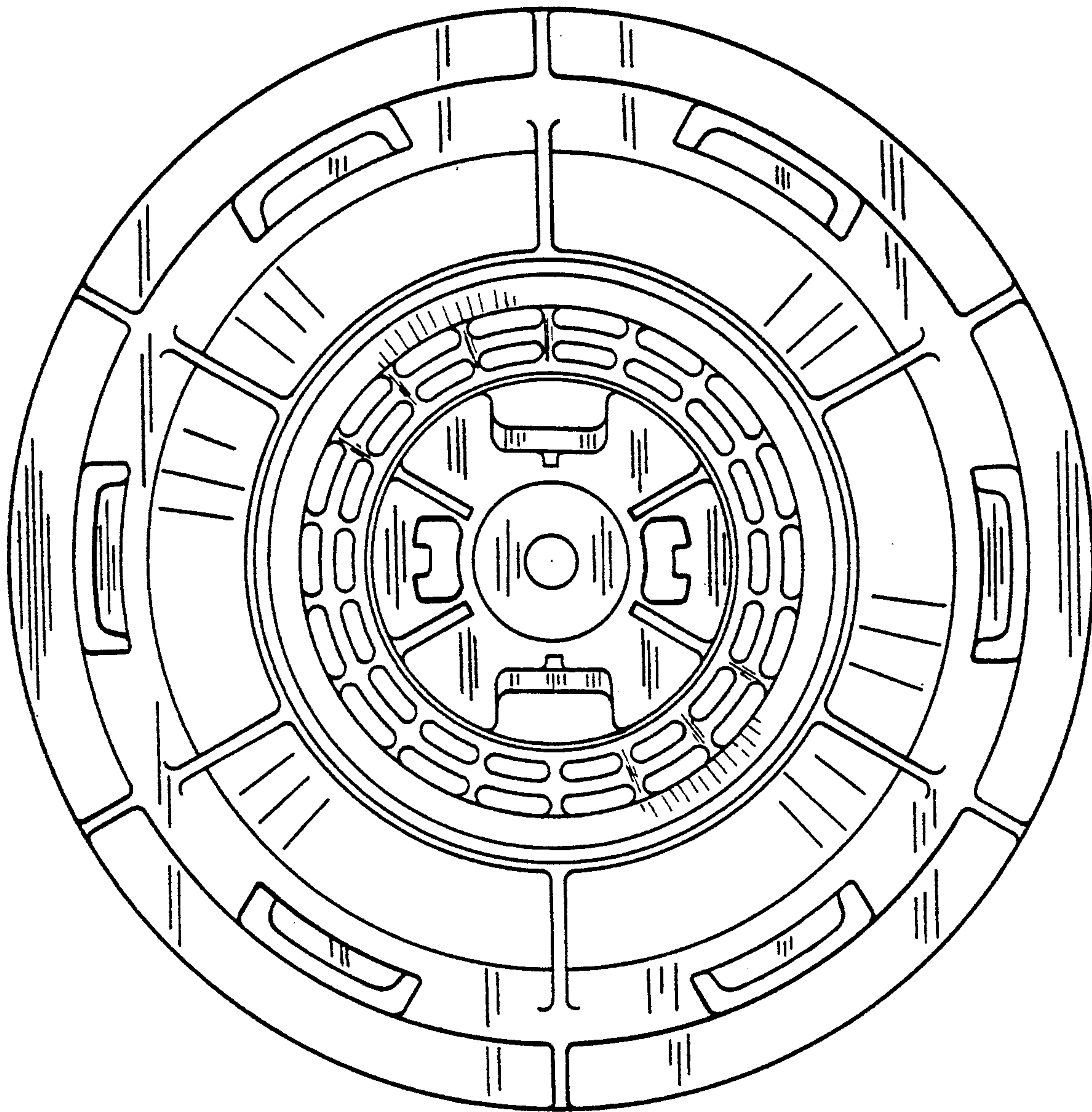

FIG. 3

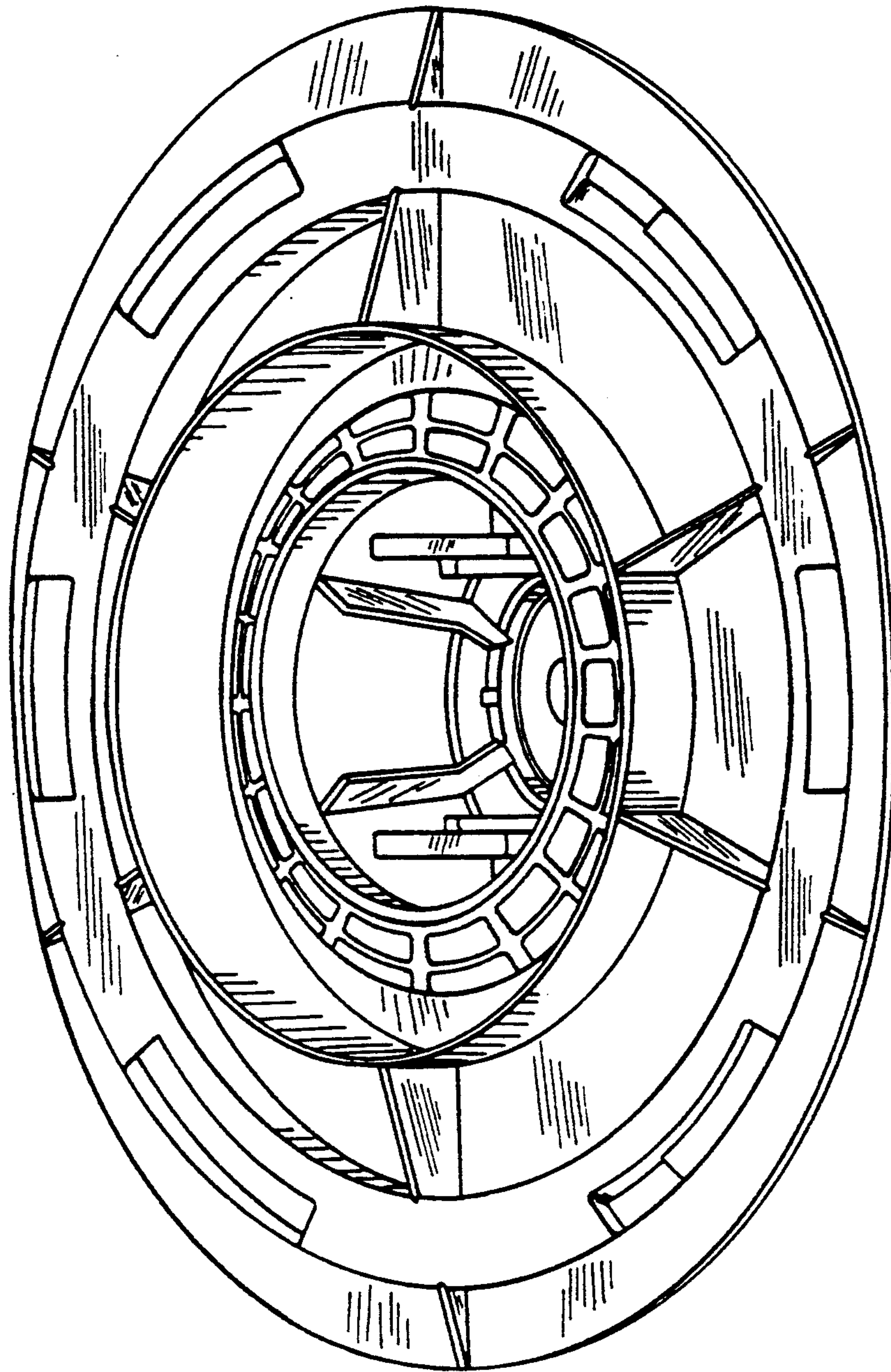

FIG. 4

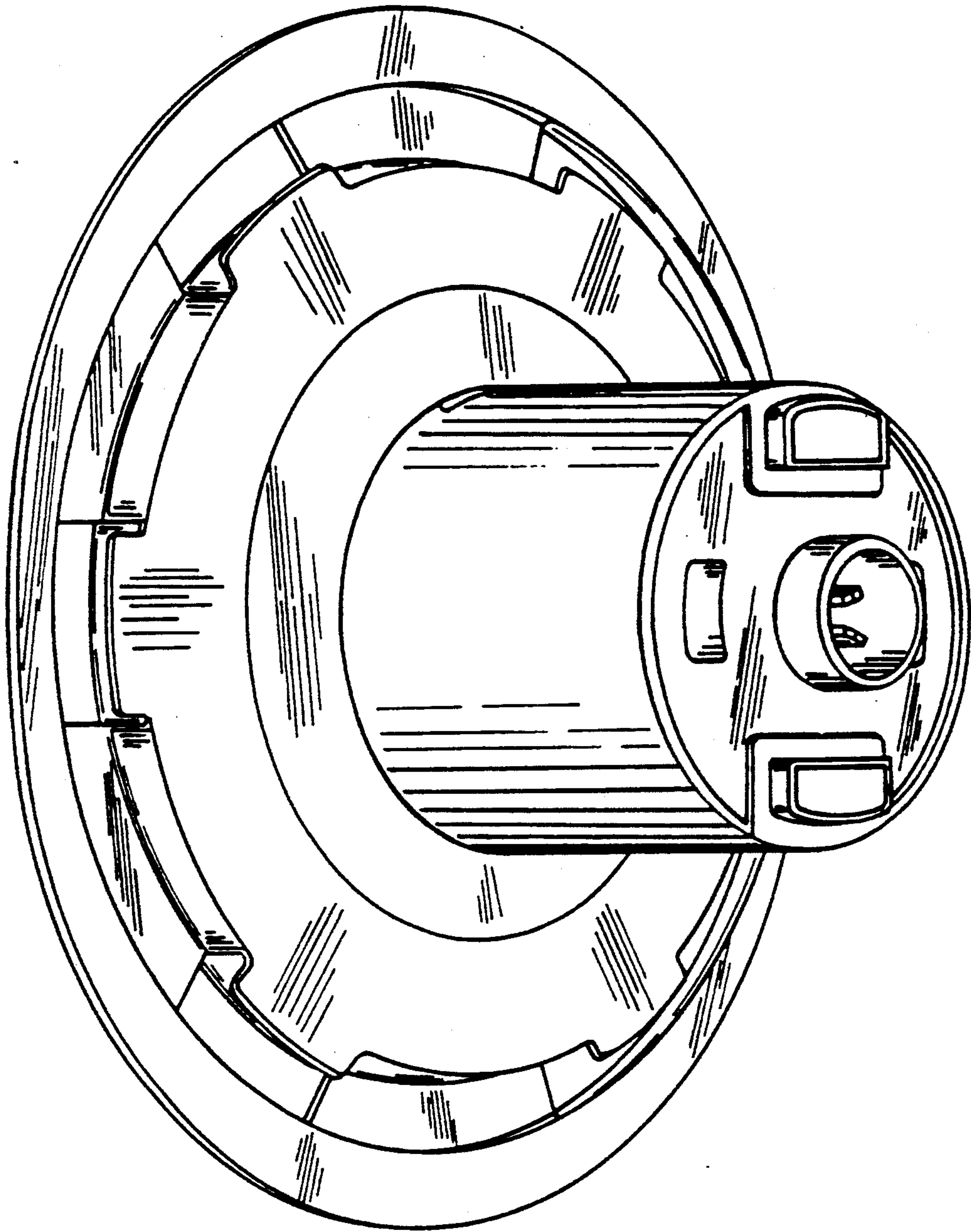

FIG. 5