



US00D347029S

United States Patent [19]
Sampedro

[11] **Patent Number: Des. 347,029**
[45] **Date of Patent: ** May 17, 1994**

[54] **WAGON**

[75] **Inventor: Tony G. Sampedro, Damascus, Ohio**

[73] **Assignee: Mahoning Valley Manufacturing, Damascus, Ohio**

[**] **Term: 14 Years**

[21] **Appl. No.: 847,478**

[22] **Filed: Mar. 6, 1992**

[52] **U.S. Cl. D21/71**

[58] **Field of Search 446/440, 451; 280/87.01, 87.021, 87.041, 87.043, 827, 282, 62, 270, 293, 274, 281.1, 288.2, 288.3, 263; 180/219; D21/71, 74, 76, 78, 80-81, 134, 137; D12/87, 110**

[56] **References Cited**

U.S. PATENT DOCUMENTS

D. 136,950	1/1944	Dodson	D21/71
D. 296,225	6/1988	Armstrong	D21/71
D. 308,992	7/1990	Wagner	D21/71
D. 316,281	4/1991	Mirisch, Sr.	D21/71
1,524,513	1/1925	Ferris	D21/71

OTHER PUBLICATIONS

Sears Catalog 1981 p. 592 #2.
Mahoning Valley Mfg. Inc. advertisement for Carry All.

Primary Examiner—Bernard Ansher
Assistant Examiner—R. Barkai
Attorney, Agent, or Firm—Calfee, Halter & Griswold

[57] **CLAIM**

The ornamental design for the wagon, as shown and described.

DESCRIPTION

FIG. 1 is a fragmentary perspective view of the front of the wagon showing my new design;
FIG. 2 is a fragmentary perspective view of the rear of the wagon;
FIG. 3 is a top view of the wagon;
FIG. 4 is a side view of the wagon;
FIG. 5 is a front view of the wagon;
FIG. 6 is a rear view of the wagon;
FIG. 7 is a bottom view of the wagon; and,
FIG. 8 is a sectional view of the wagon as seen along the line 8—8 of FIG. 3.

The broken line showing of seat belts in FIGS. 1-3 are for illustrative purposes only and form no part of the claimed design.

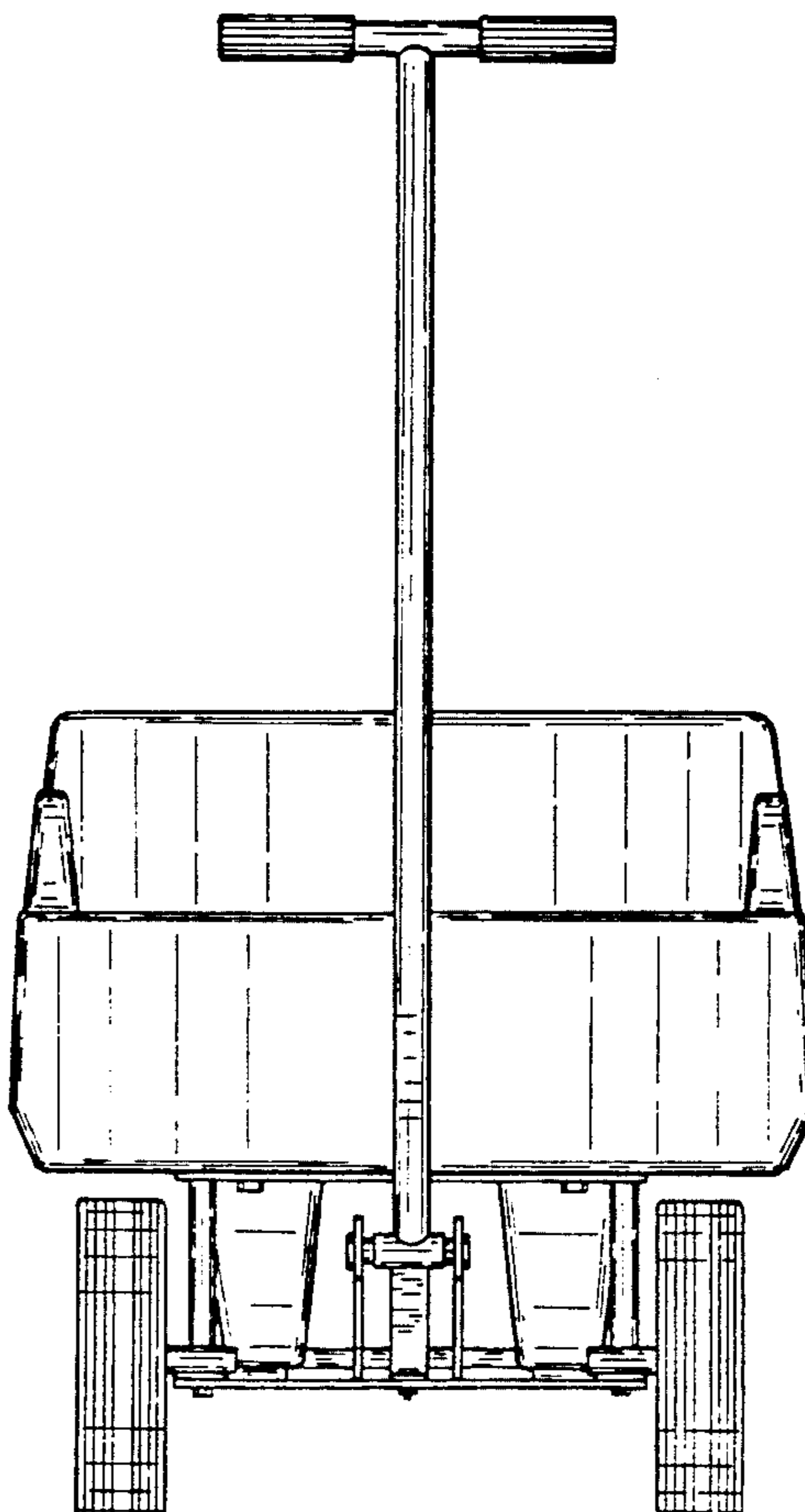

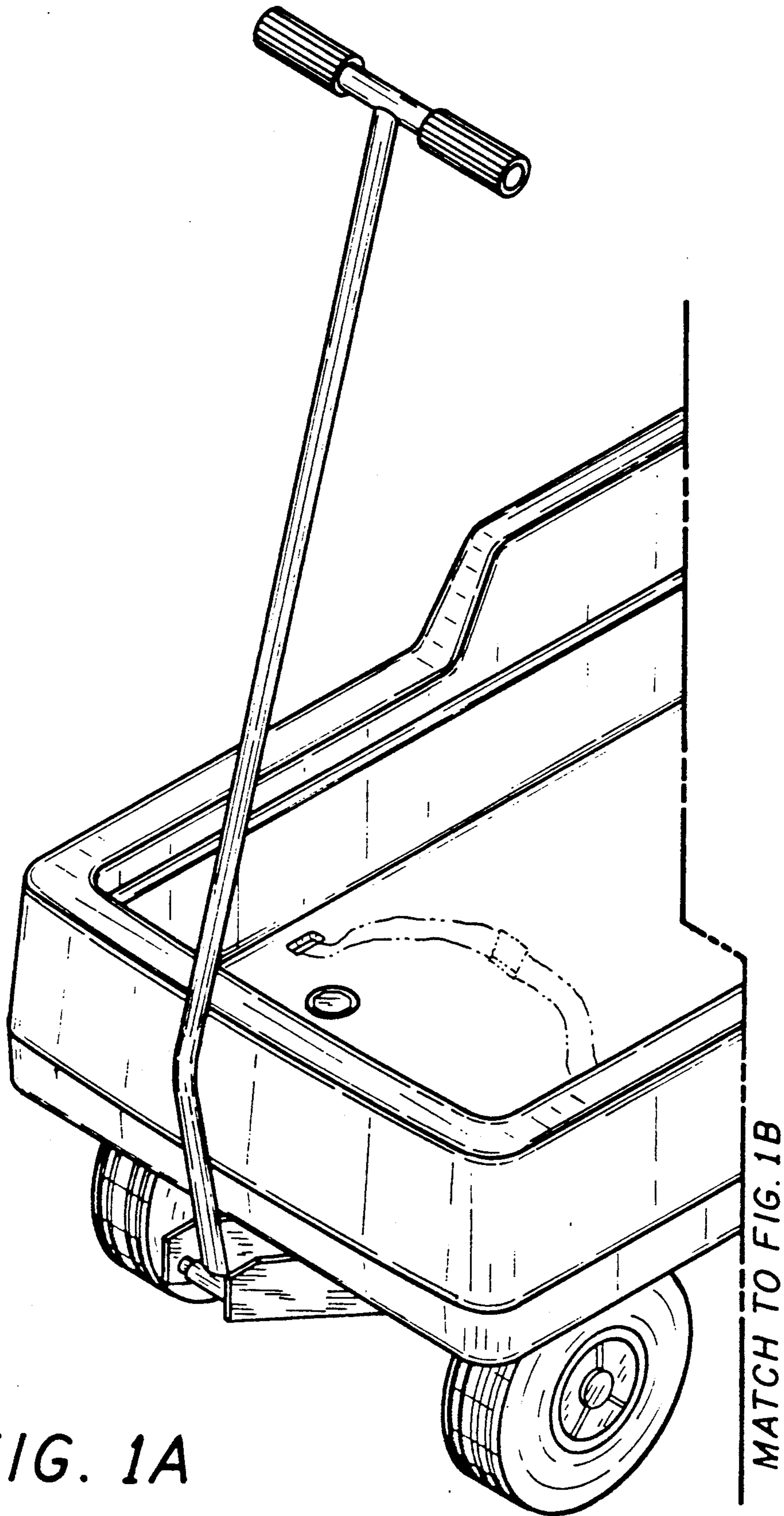
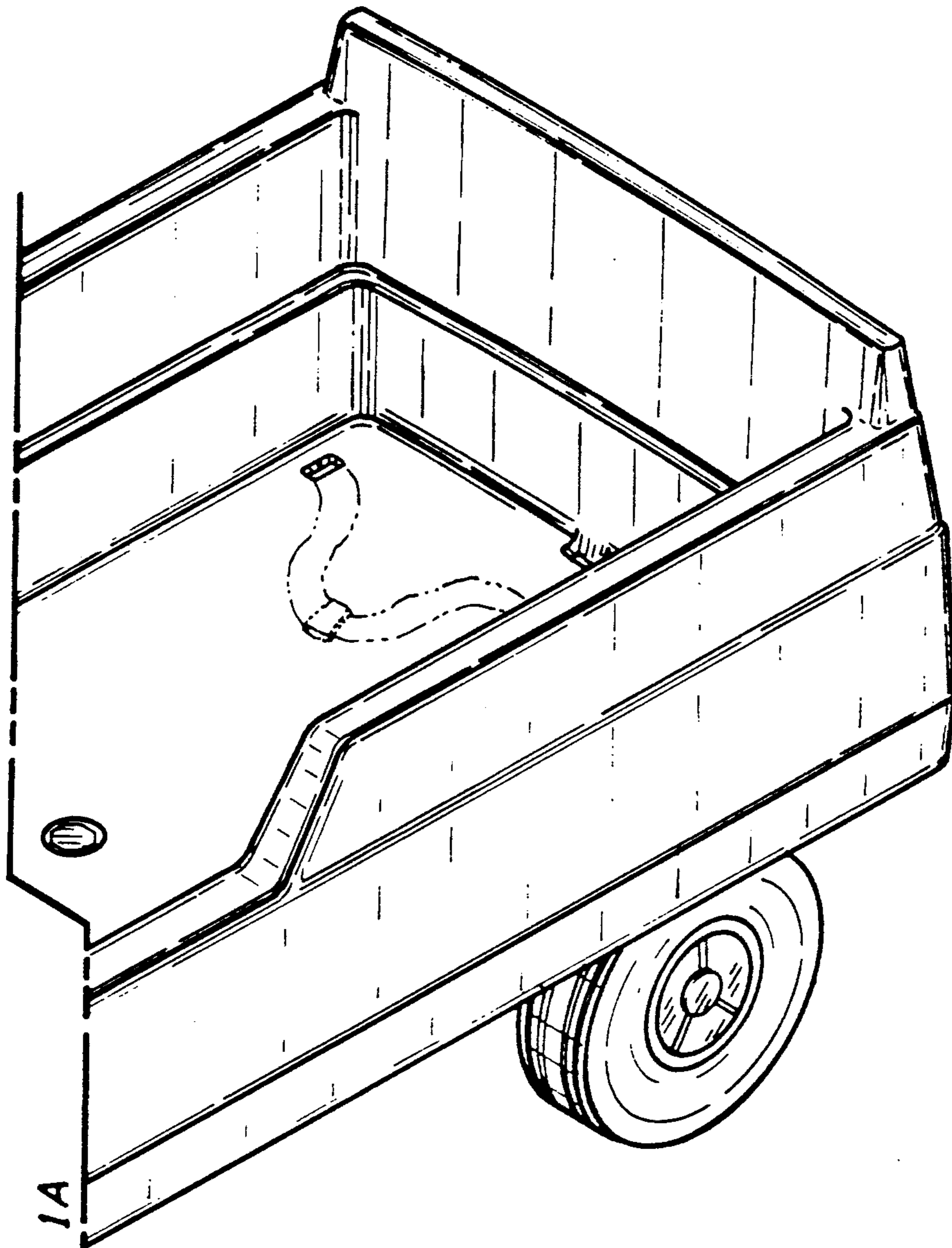

FIG. 1A



MATCH TO FIG. 1A

FIG. 1B

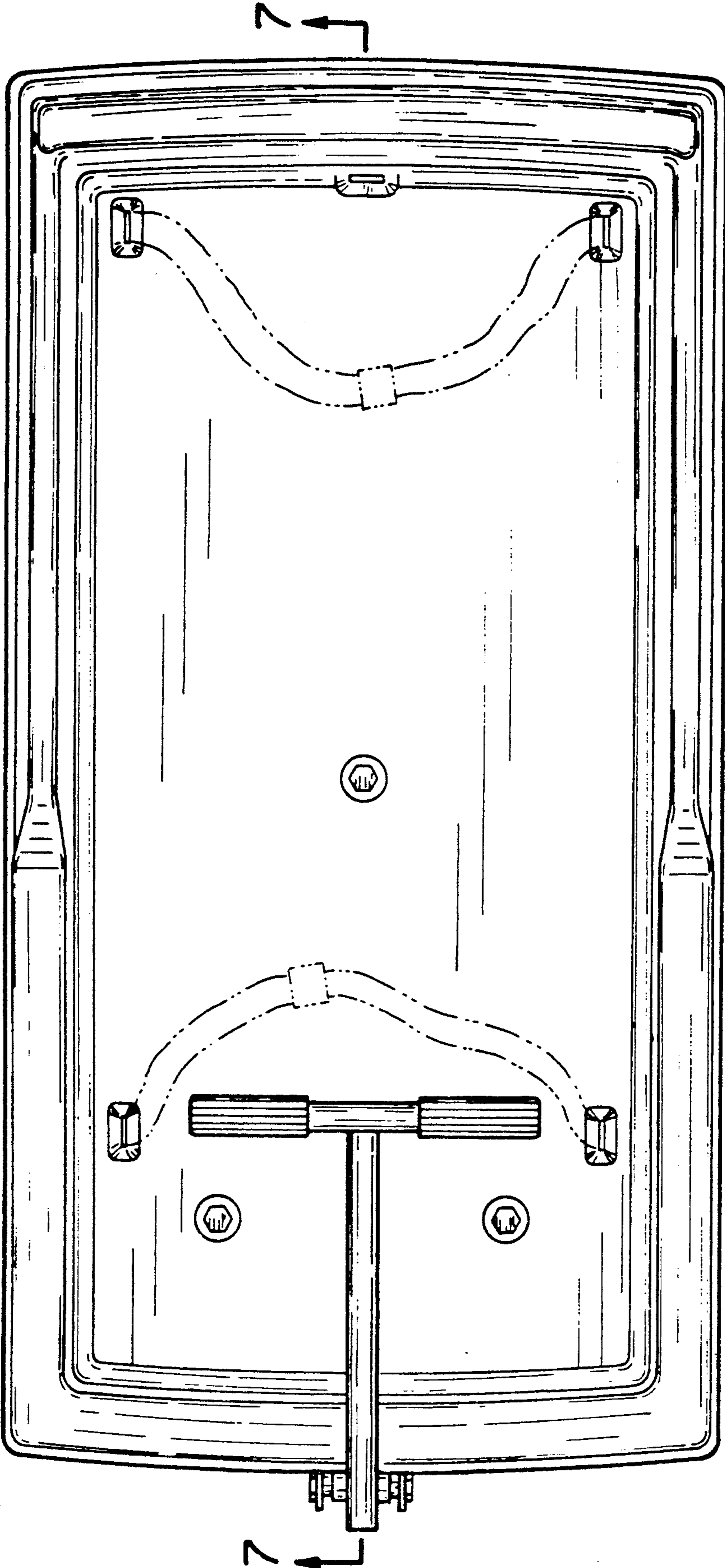
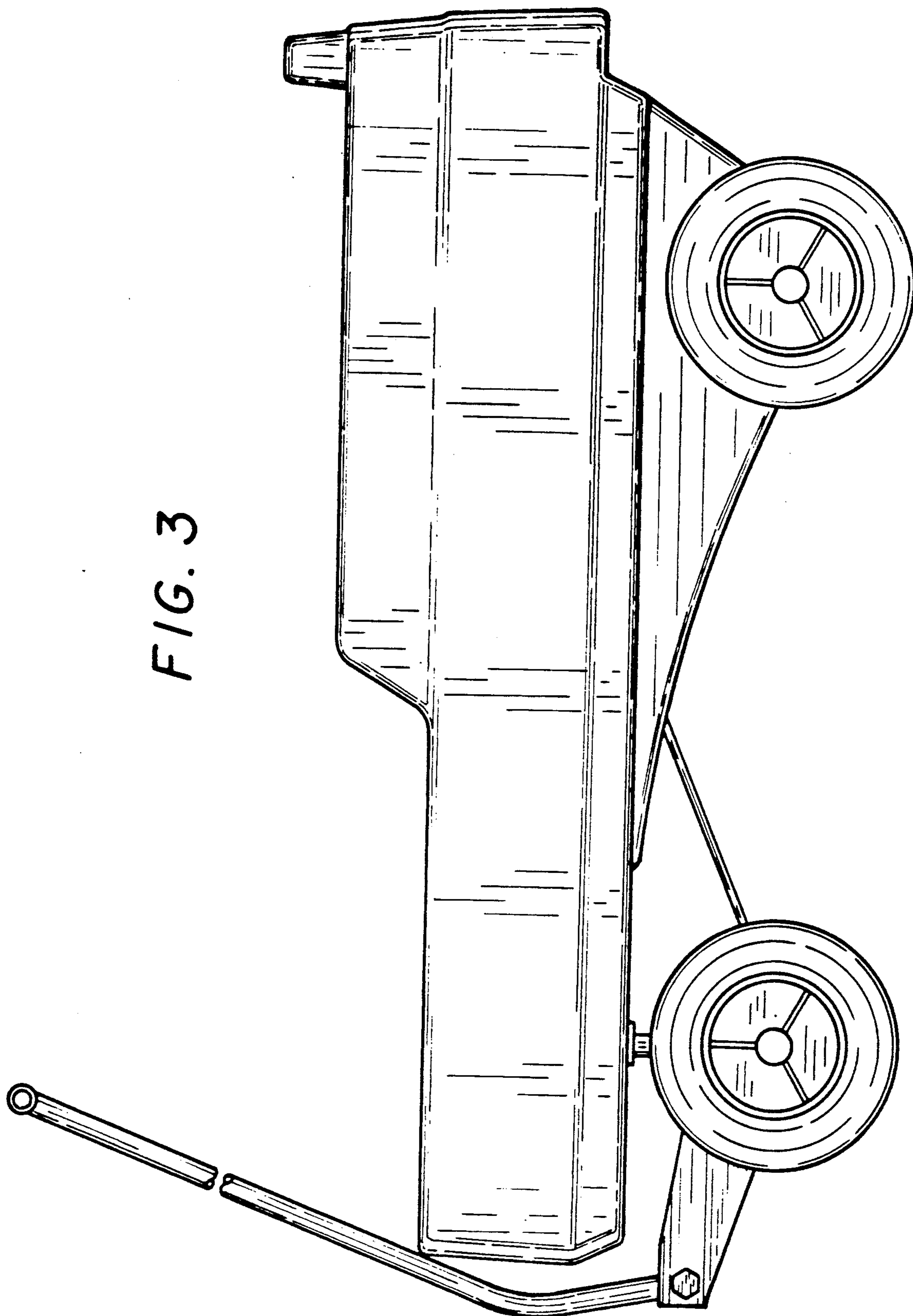

FIG. 2

FIG. 3



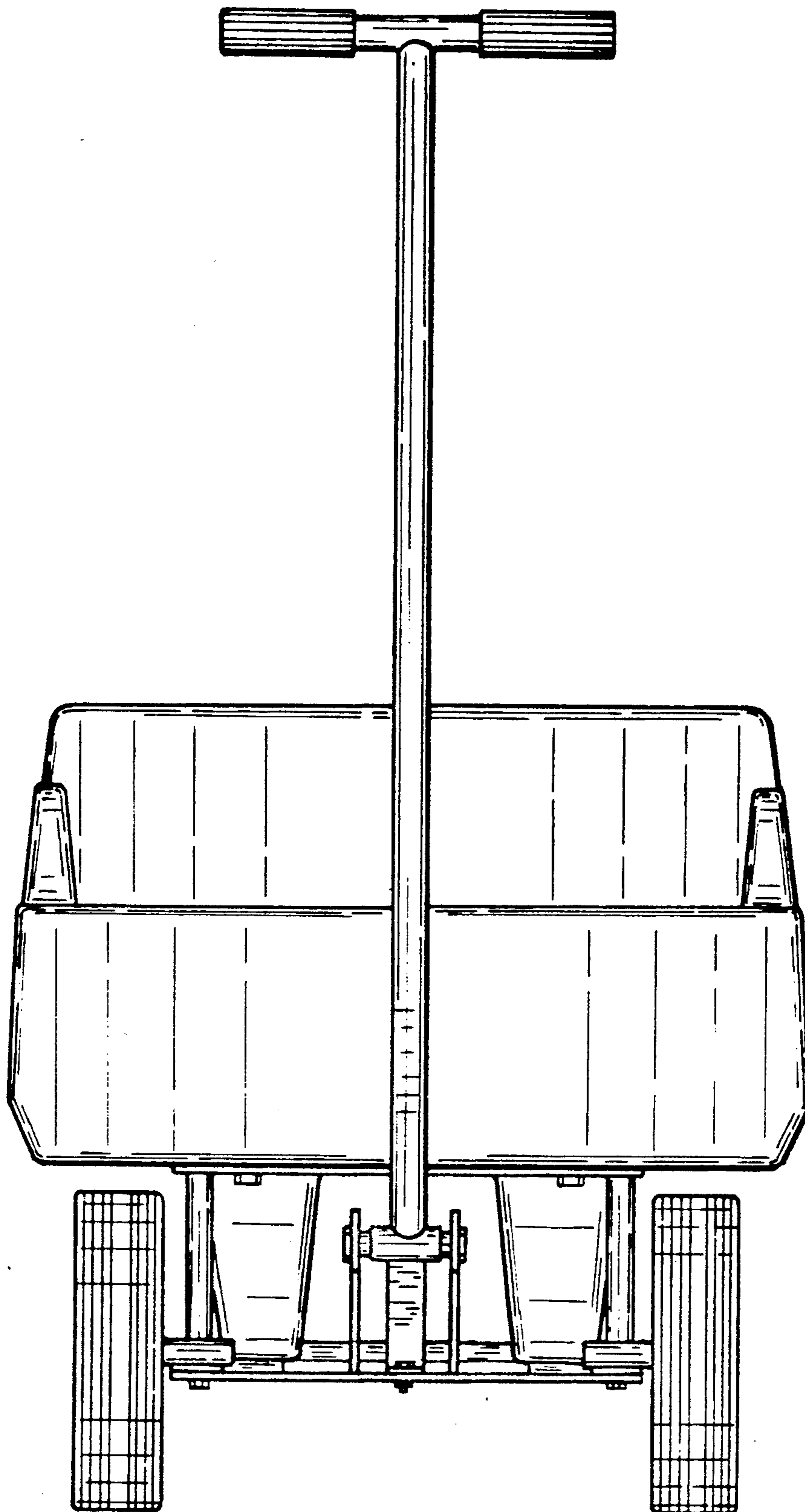

FIG. 4

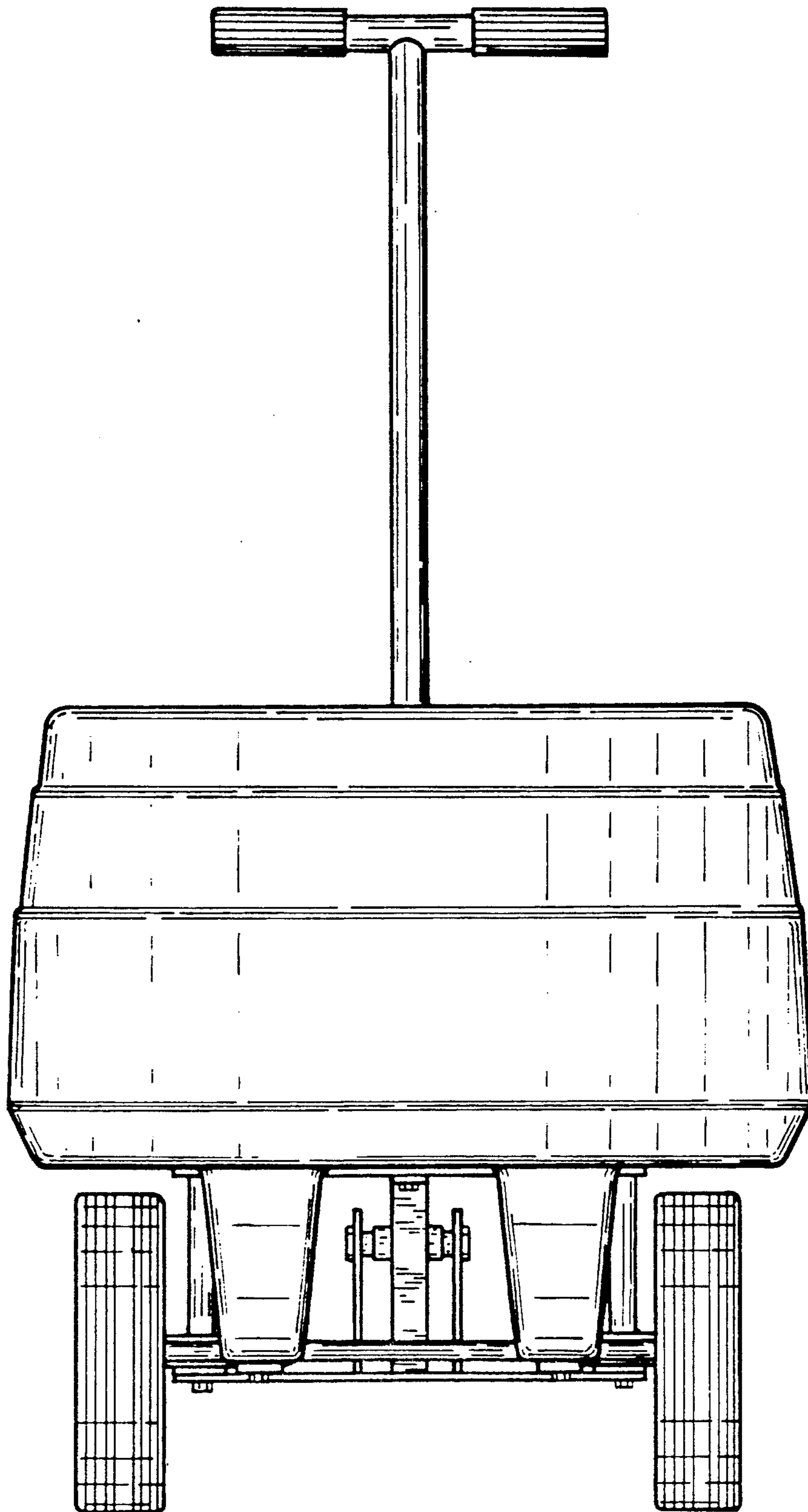

FIG. 5

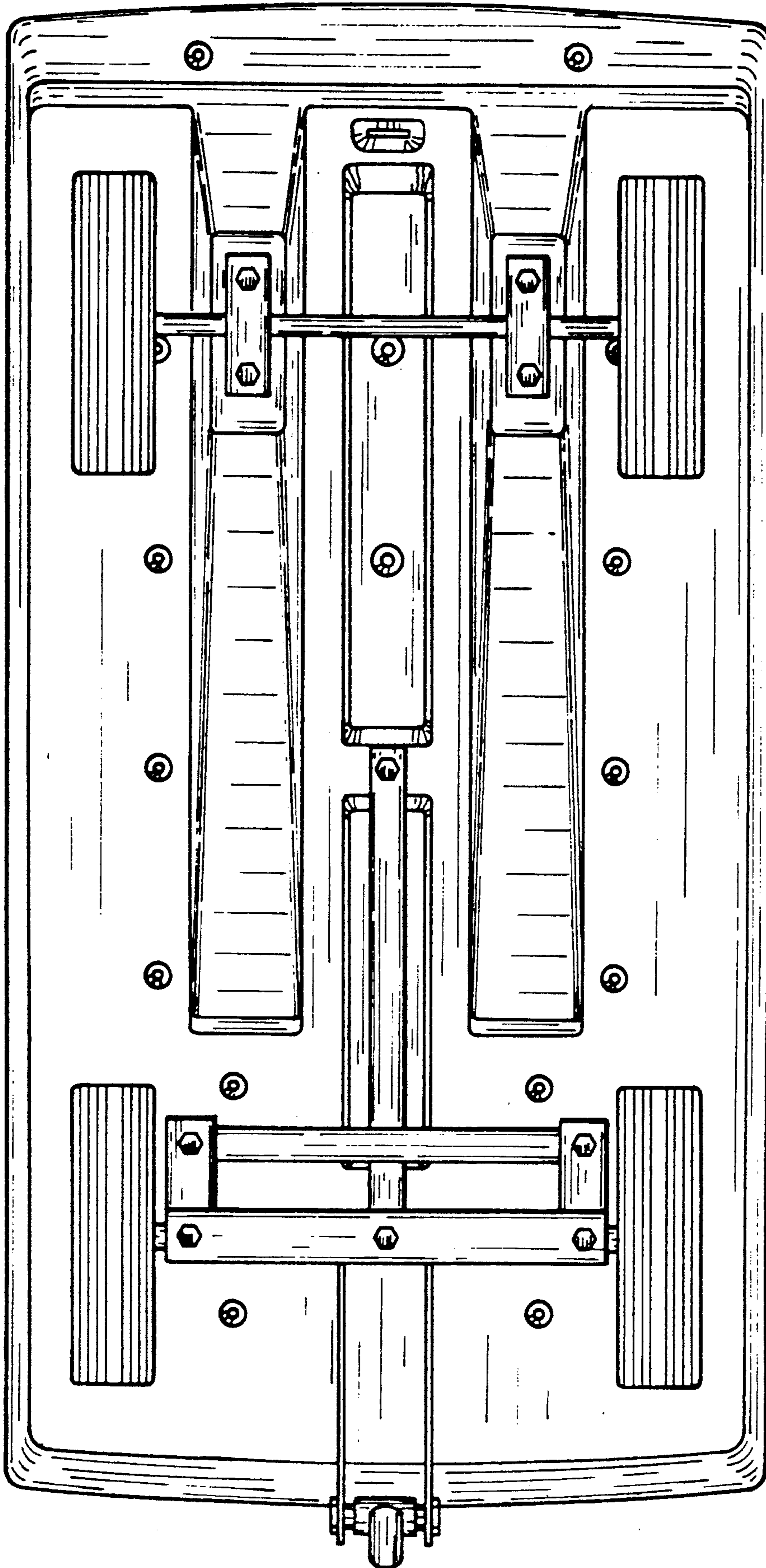

FIG. 6

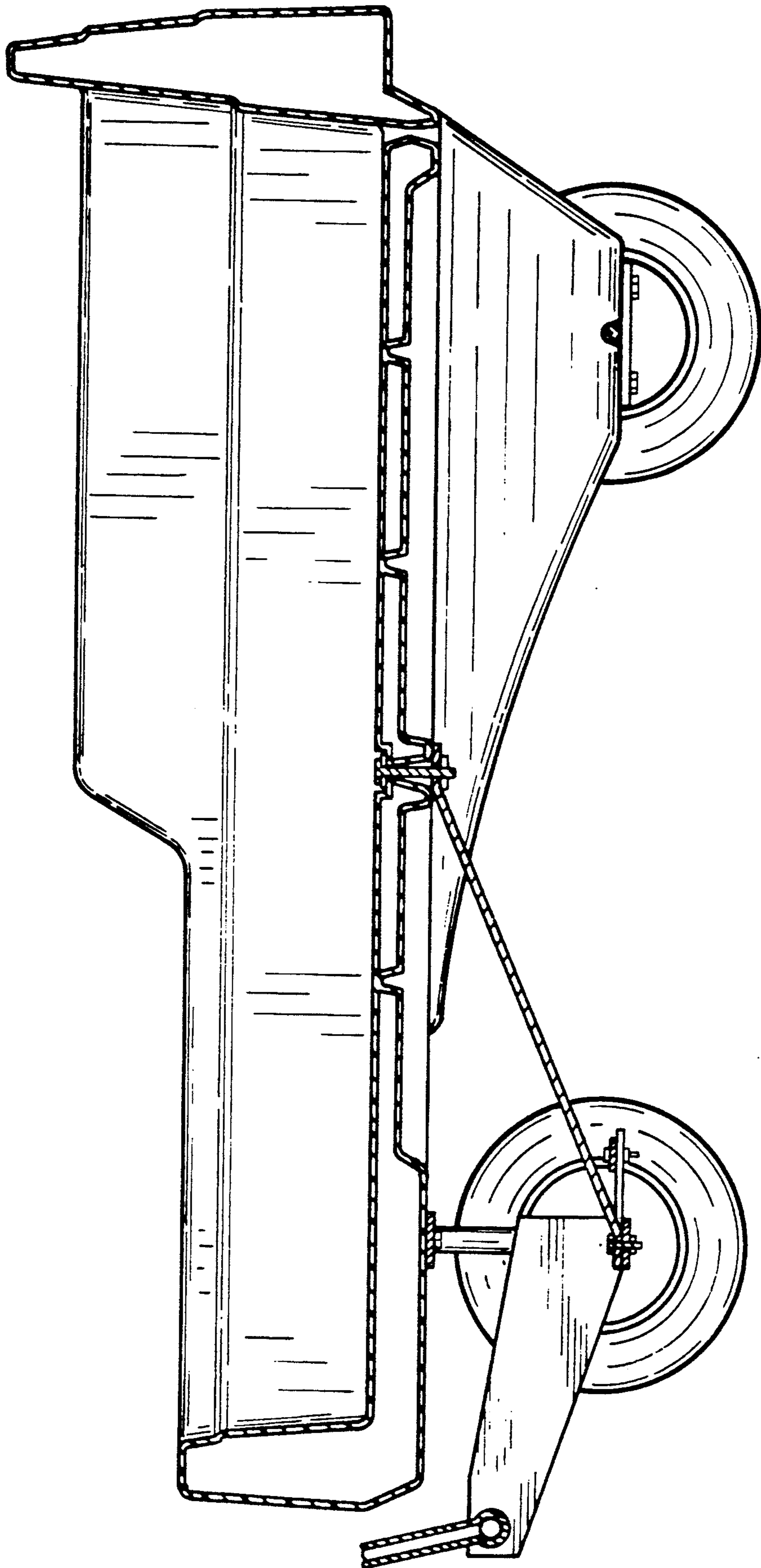

FIG. 7