



US00D347021S

United States Patent [19]

[11] Patent Number: **Des. 347,021**

Adams et al.

[45] Date of Patent: **** May 17, 1994**

[54] **THERMAL TRANSFER PRINTER**

[75] Inventors: **Vincent C. Adams**, Buffalo Grove, Ill.; **Jarl A. Anderson**, Northborough, Mass.; **William C. Cesaroni**, Glenview; **Alvin C. Skat, Jr.**, Elmhurst, both of Ill.

[73] Assignee: **Zebra Technologies Corporation**, Vernon Hills, Ill.

[**] Term: **14 Years**

[21] Appl. No.: **941,948**

[22] Filed: **Sep. 8, 1992**

[52] U.S. Cl. **D18/50**

[58] Field of Search 400/690-694, 400/613, 613.1-613.4, 690.1-690.4; D14/100, 106; D18/6, 11, 19, 34, 46, 49, 50, 52-55; D19/67-69

D. 324,234	2/1992	Tanaka	D18/54
D. 325,927	5/1992	Fushiya	D18/54
D. 328,098	7/1992	Czech	D19/69
D. 328,312	7/1992	Halm	D19/69
D. 337,787	7/1993	Oga et al.	D19/69
D. 338,493	8/1993	Mead	D19/69

Primary Examiner—Cathy Anne MacCormac
Attorney, Agent, or Firm—Trexler, Bushnell, Giangiorgi & Blackstone, Ltd.

[57] **CLAIM**

The ornamental design for the thermal transfer printer, as shown.

DESCRIPTION

FIG. 1 is a front elevational view of the thermal transfer printer of the present invention; FIG. 2 is a rear elevational view of the thermal transfer printer of the present invention; FIG. 3 is a left side elevational view of the thermal transfer printer of the present invention; FIG. 4 is a right side elevational view of the thermal transfer printer of the present invention; FIG. 5 is a top plan view of the thermal transfer printer of the present invention; FIG. 6 is a bottom plan view of the thermal transfer printer of the present invention; and, FIG. 7 is a perspective view of the thermal transfer printer of the present invention.

[56] **References Cited**

U.S. PATENT DOCUMENTS

D. 126,732	4/1941	Reinecke	D19/68
D. 294,357	2/1988	Klein et al.	D18/55
D. 294,405	2/1988	Man Yau	D18/50
D. 298,440	11/1988	Kida	D19/69
D. 310,102	8/1990	Rittenhouse	D19/67
D. 323,526	1/1992	Kokayashi	D18/54

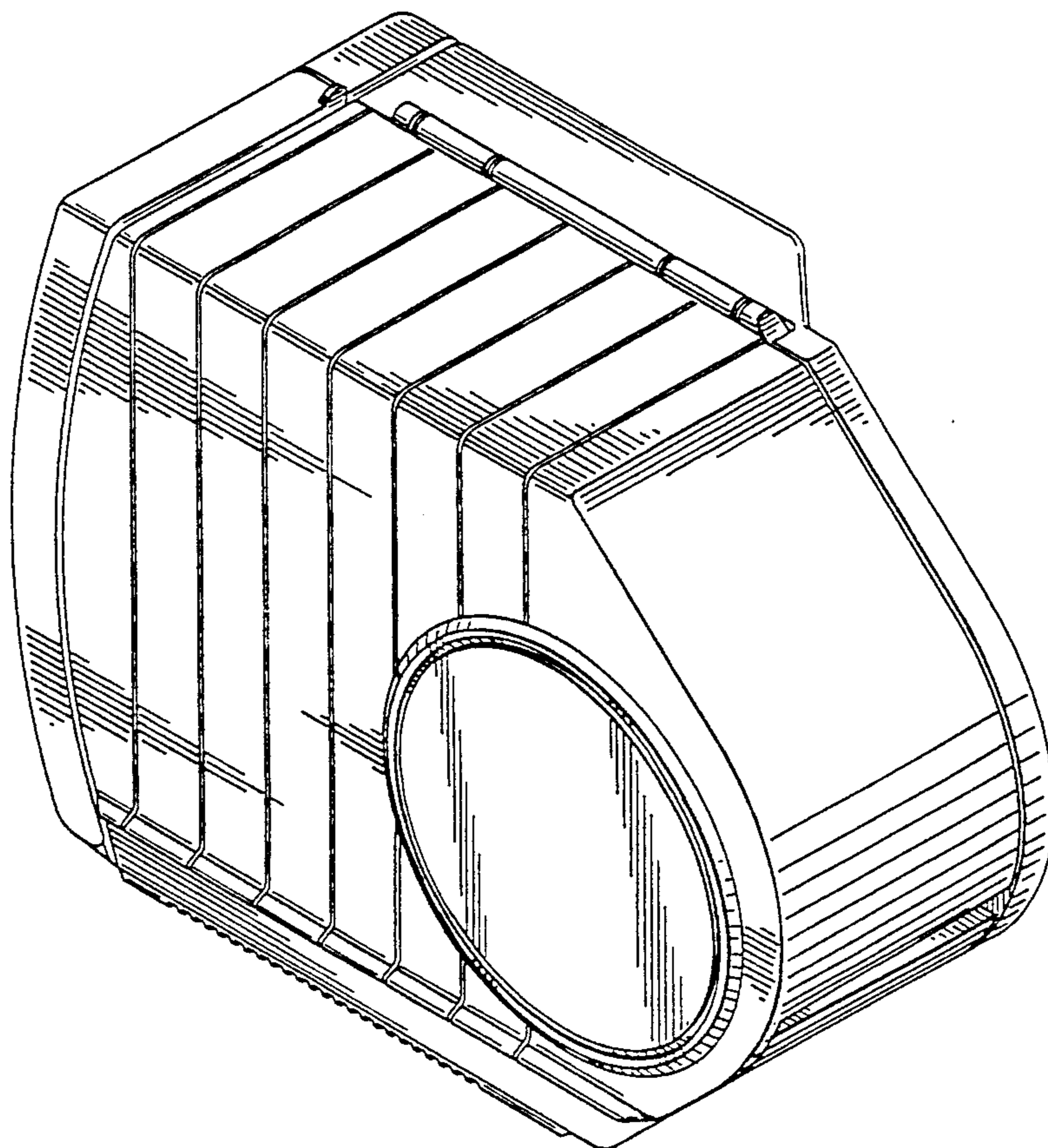
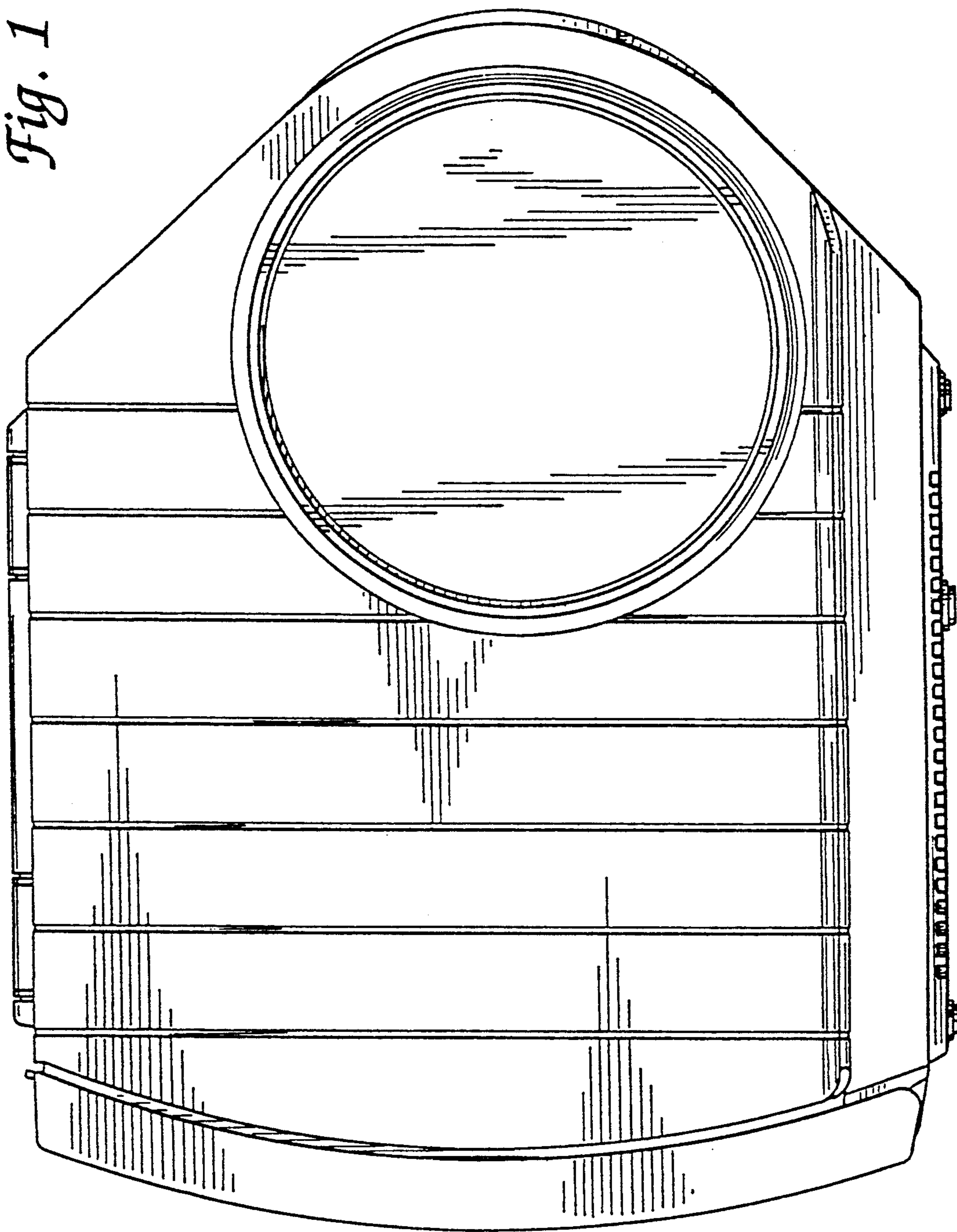

Fig. 1



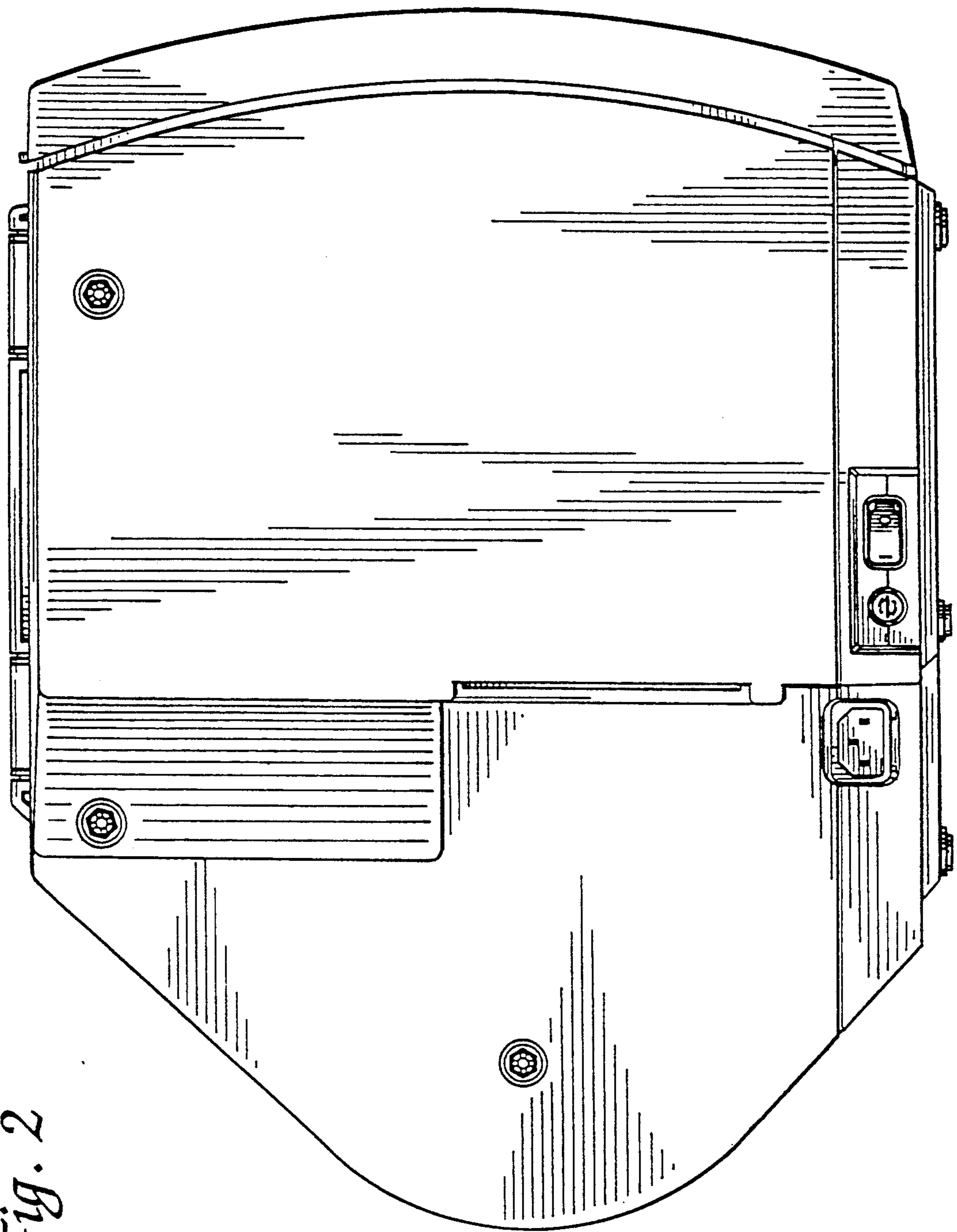

Fig. 2

Fig. 3

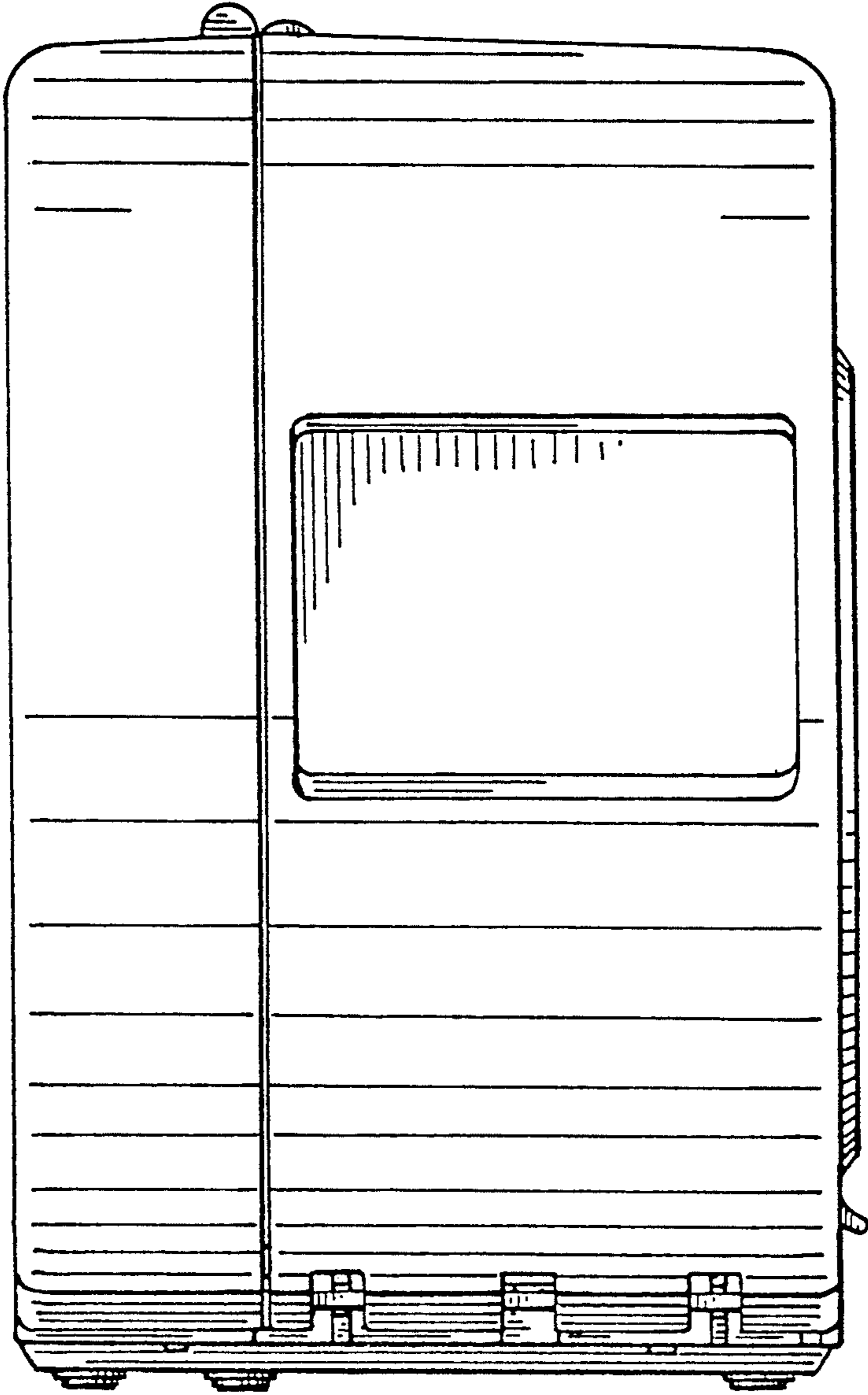

Fig. 4

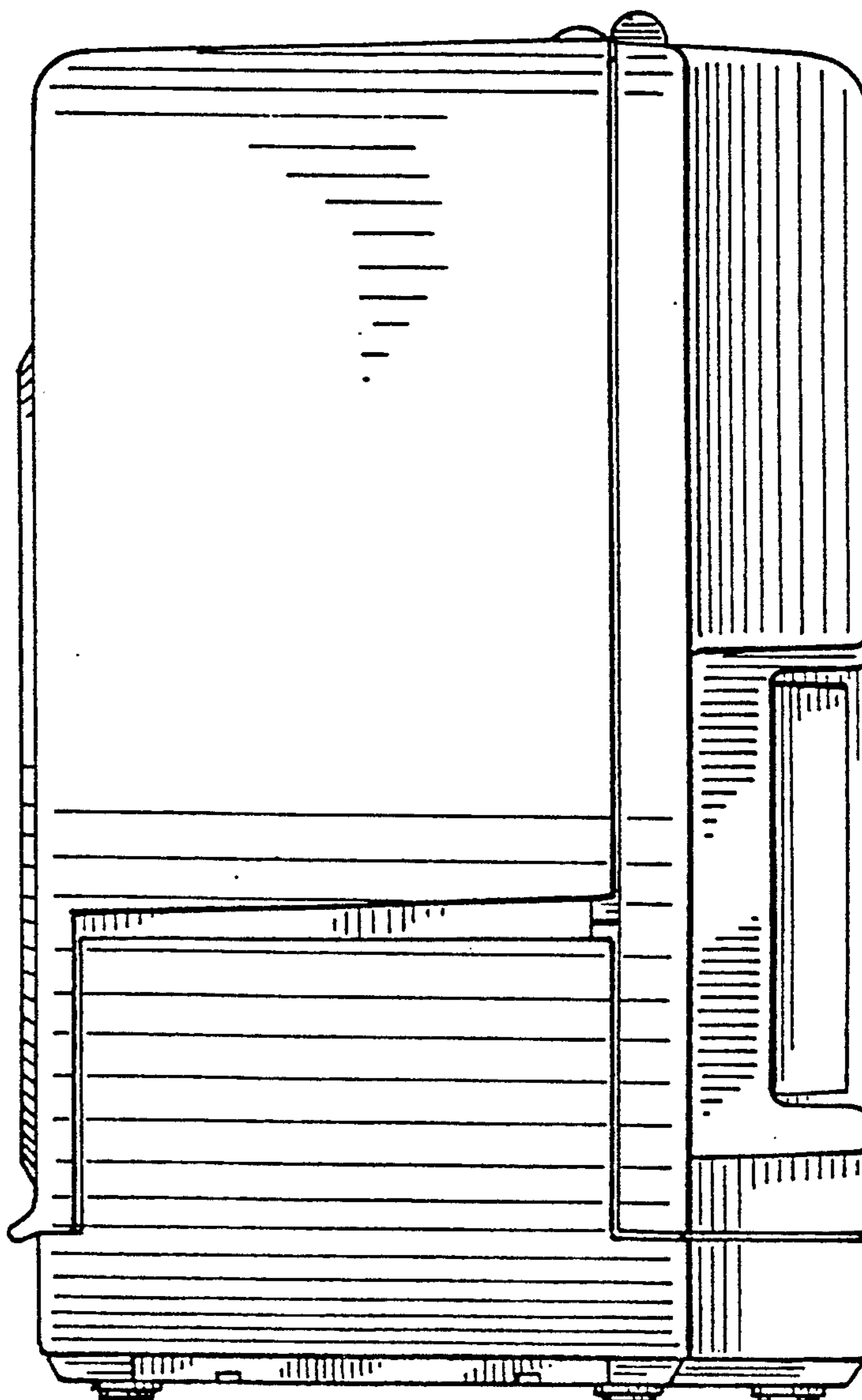

Fig. 5

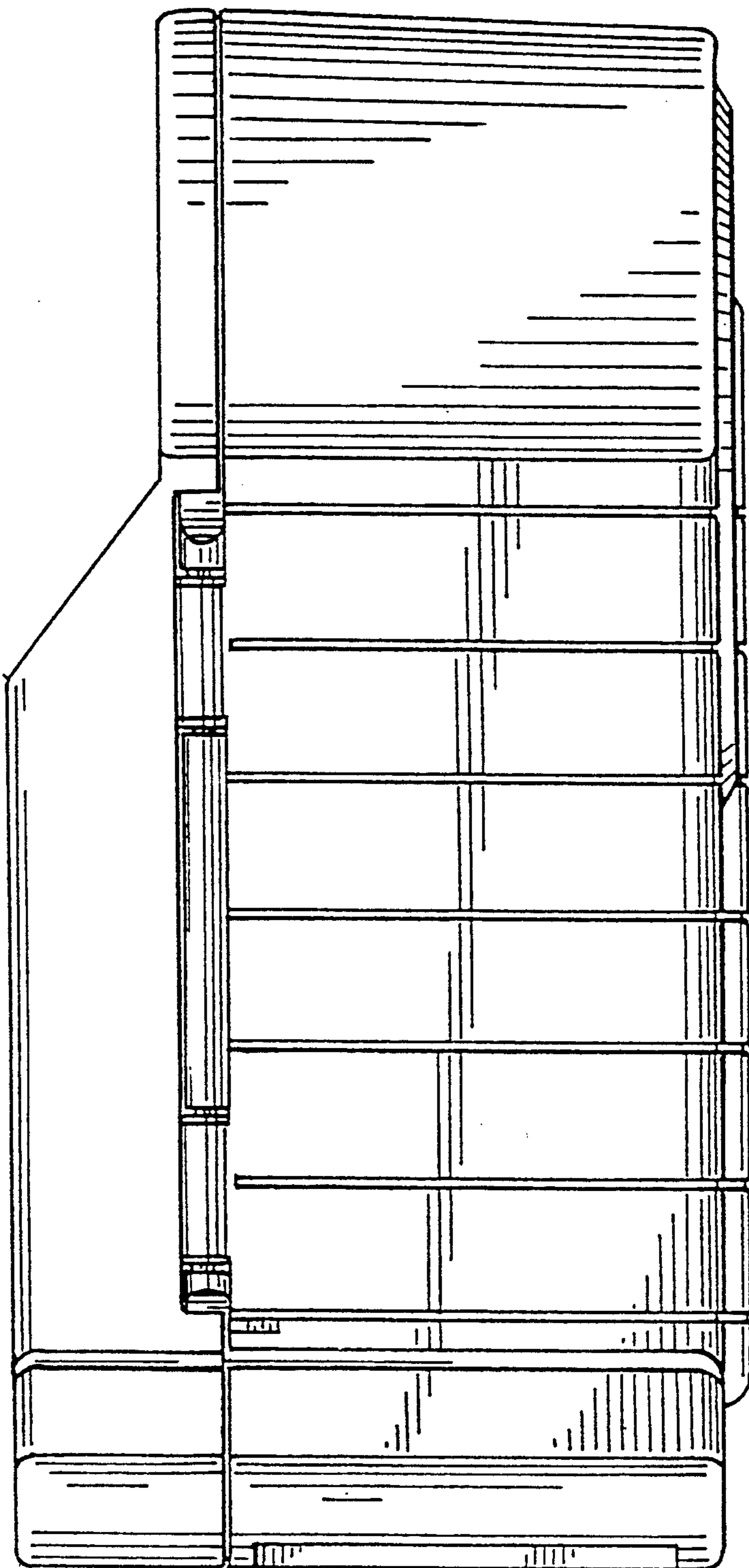

Fig. 6

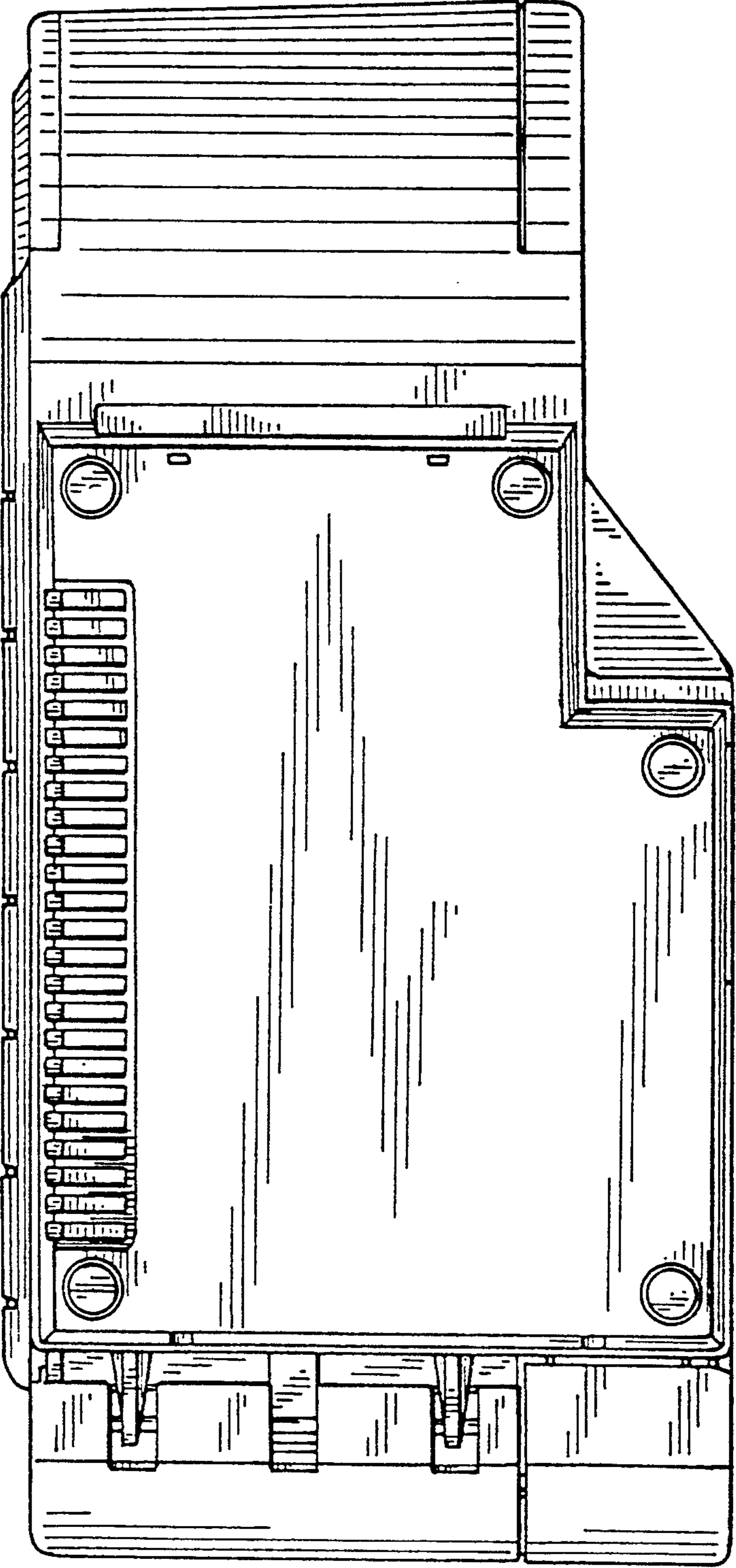

Fig. 7

