



US00D346990S

United States Patent [19]

[11] Patent Number: **Des. 346,990**

Abbott et al.

[45] Date of Patent: **** May 17, 1994**

[54] **AUTOMOBILE**

[75] Inventors: **Glenn W. Abbott, Waterford; John P. Sgalia, Farmington Hills, both of Mich.**

[73] Assignee: **Chrysler Corporation, Highland Park, Mich.**

[**] Term: **14 Years**

[21] Appl. No.: **1,538**

[22] Filed: **Nov. 17, 1992**

[52] U.S. Cl. **D12/91**

[58] Field of Search **296/185; D12/90-92**

[56] **References Cited
PUBLICATIONS**

Design News, Jul. 18, 1977, p. 14, RSV Automobile, center left side of page.

Popular Mechanics, Apr. 1989, p. 72, Jeep Concept I Vehicle, bottom of page.

Motor Trend, Feb. 1990, p. 17, Suzuki Constellation Automobile, second photograph down from top left side of page.

Road & Track, Sep. 1991, p. 46, Dodge Neon Automobile, bottom of page.

Primary Examiner—James M. Gandy
Attorney, Agent, or Firm—Mark P. Calcaterra

[57] **CLAIM**

The ornamental design for an automobile, as shown and described.

DESCRIPTION

FIG. 1 is a front perspective view of an automobile constructed in accordance to the teachings of the present invention; and,

FIG. 2 is a rear perspective view of the automobile shown in FIG. 1, it being understood that the side of the automobile opposite to that shown is a mirror image thereof.

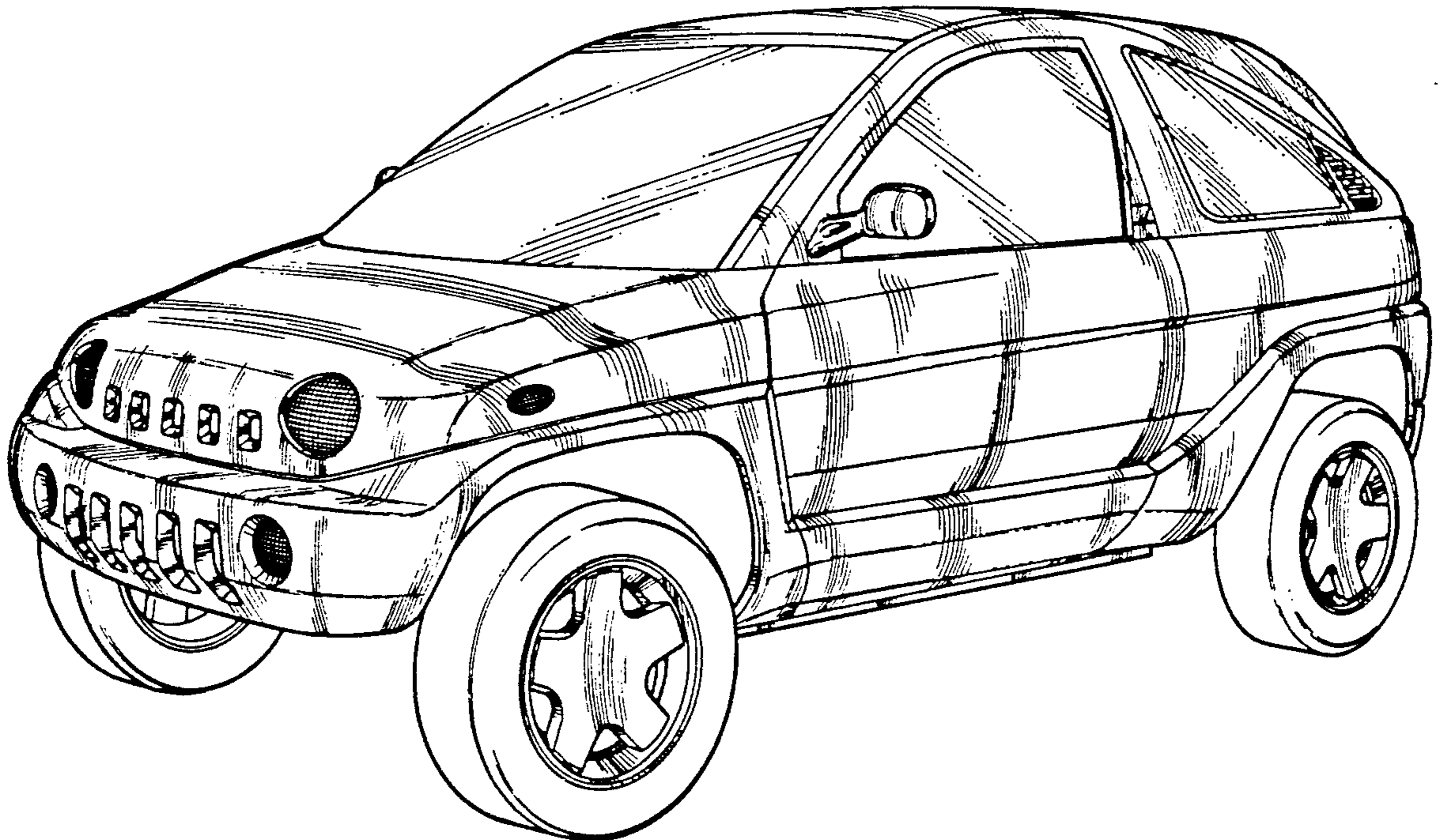

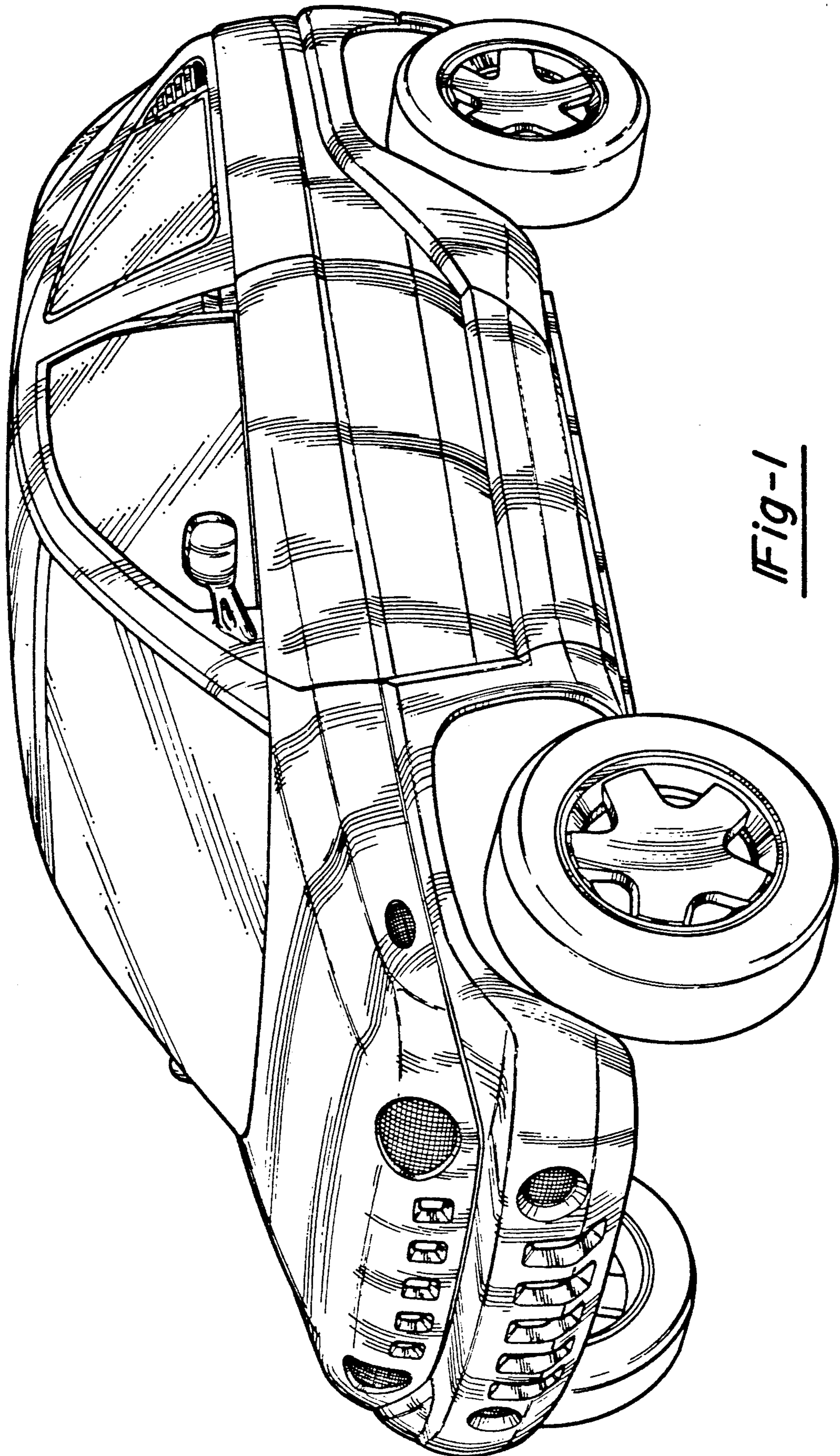

Fig-1

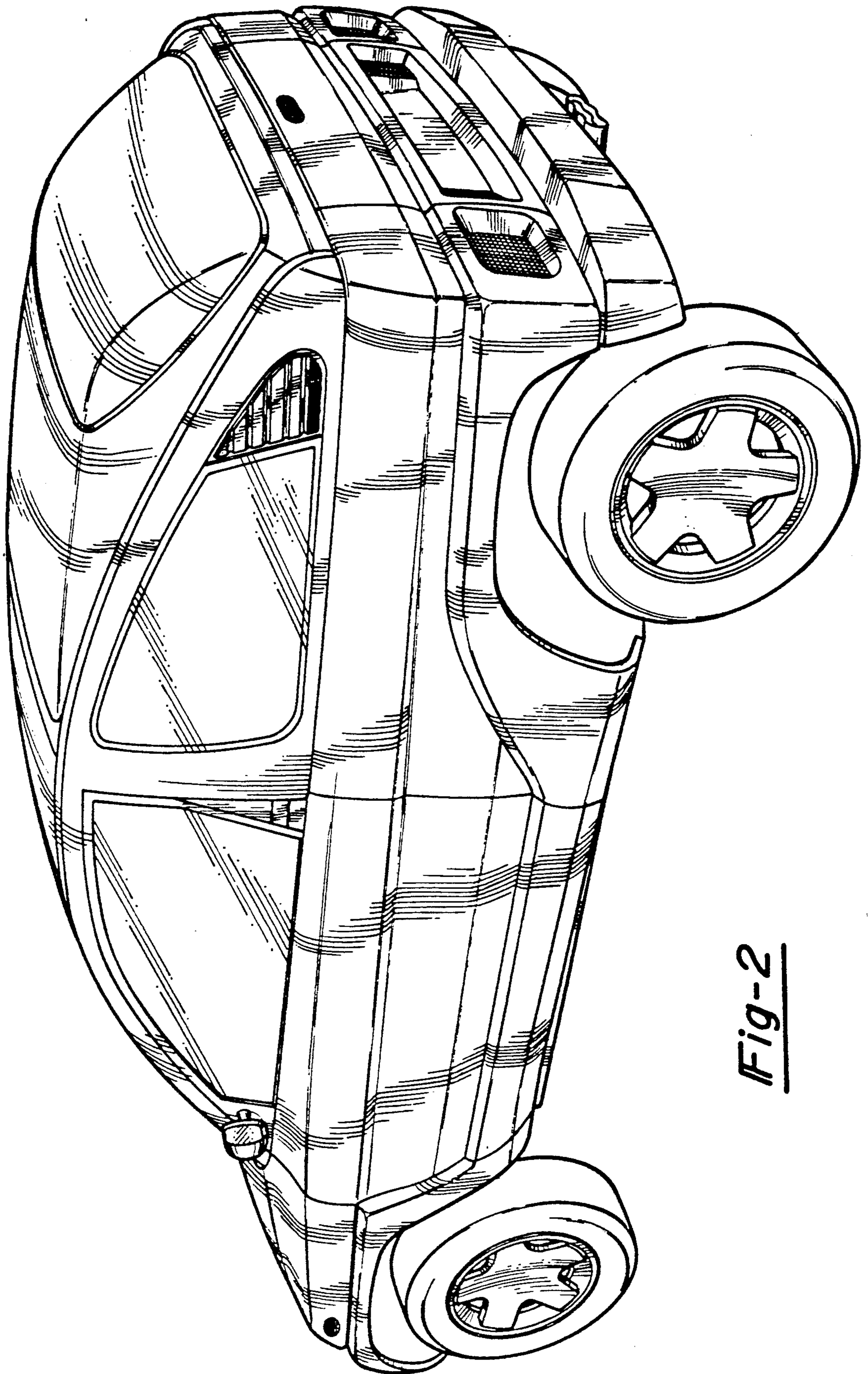

Fig-2