



US00D346982S

United States Patent [19]

[11] Patent Number: Des. 346,982

Greene et al.

[45] Date of Patent: ** May 17, 1994

[54] PORTABLE SECURITY ALARM

Assistant Examiner—Marcus Jackson
Attorney, Agent, or Firm—Townsend and Townsend
Khourie and Crew

[75] Inventors: Ted R. Greene, La Jolla; Erno Lutz,
Sunnyvale, both of Calif.

[73] Assignee: United Security Products, Inc., San
Diego, Calif.

[57] CLAIM

[**] Term: 14 Years

The ornamental design for a portable security alarm, as
shown and described.

[21] Appl. No.: 804

[22] Filed: Oct. 26, 1992

[52] U.S. Cl. D10/106

[58] Field of Search 340/541, 542, 543, 544,
340/545, 546, 547, 551, 571, 689; D10/104, 106,
121

DESCRIPTION

[56] References Cited

U.S. PATENT DOCUMENTS

D. 277,652	2/1985	Kahl, Jr. et al.	D10/106
D. 286,383	10/1986	Kotlicki et al.	D10/106
D. 330,339	10/1992	Roselle et al.	D10/106
D. 331,888	12/1992	Zade	D10/106

FIG. 1 is a perspective view of a first embodiment of a portable security alarm showing our new design; FIG. 2 is a top plan view thereof; FIG. 3 is a front elevational view thereof; FIG. 4 is a right side elevational view thereof; FIG. 5 is a left side elevational view thereof; FIG. 6 is a rear elevational view thereof; FIG. 7 is a bottom plan view thereof; FIG. 8 is a perspective view of a second embodiment of a portable security alarm showing our new design; FIG. 9 is a top plan view thereof; FIG. 10 is a front elevational view thereof; FIG. 11 is a right side elevational view thereof; FIG. 12 is a left side elevational view thereof; FIG. 13 is a rear elevational view thereof; and, FIG. 14 is a bottom plan view thereof.

Primary Examiner—Wallace R. Burke

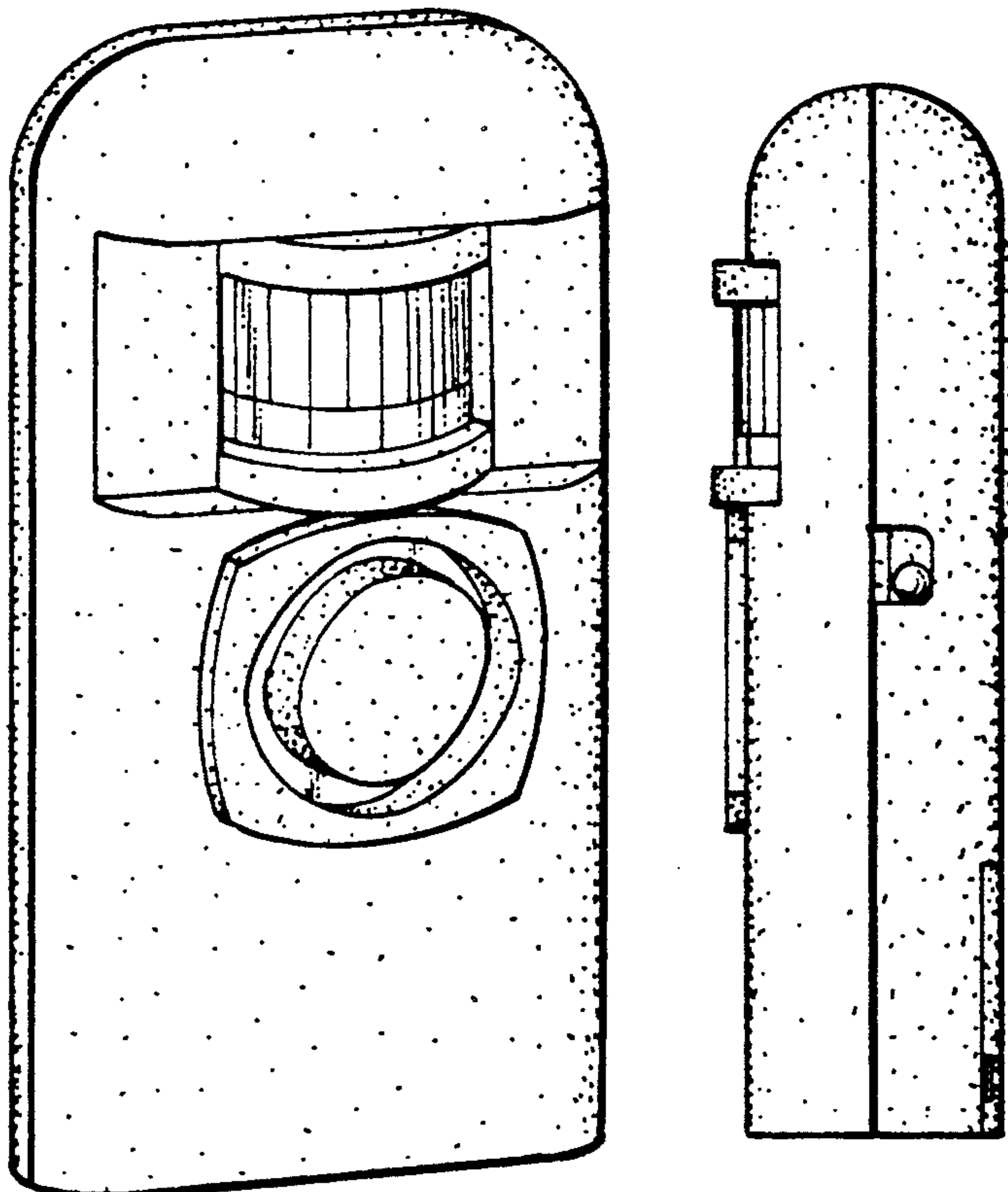

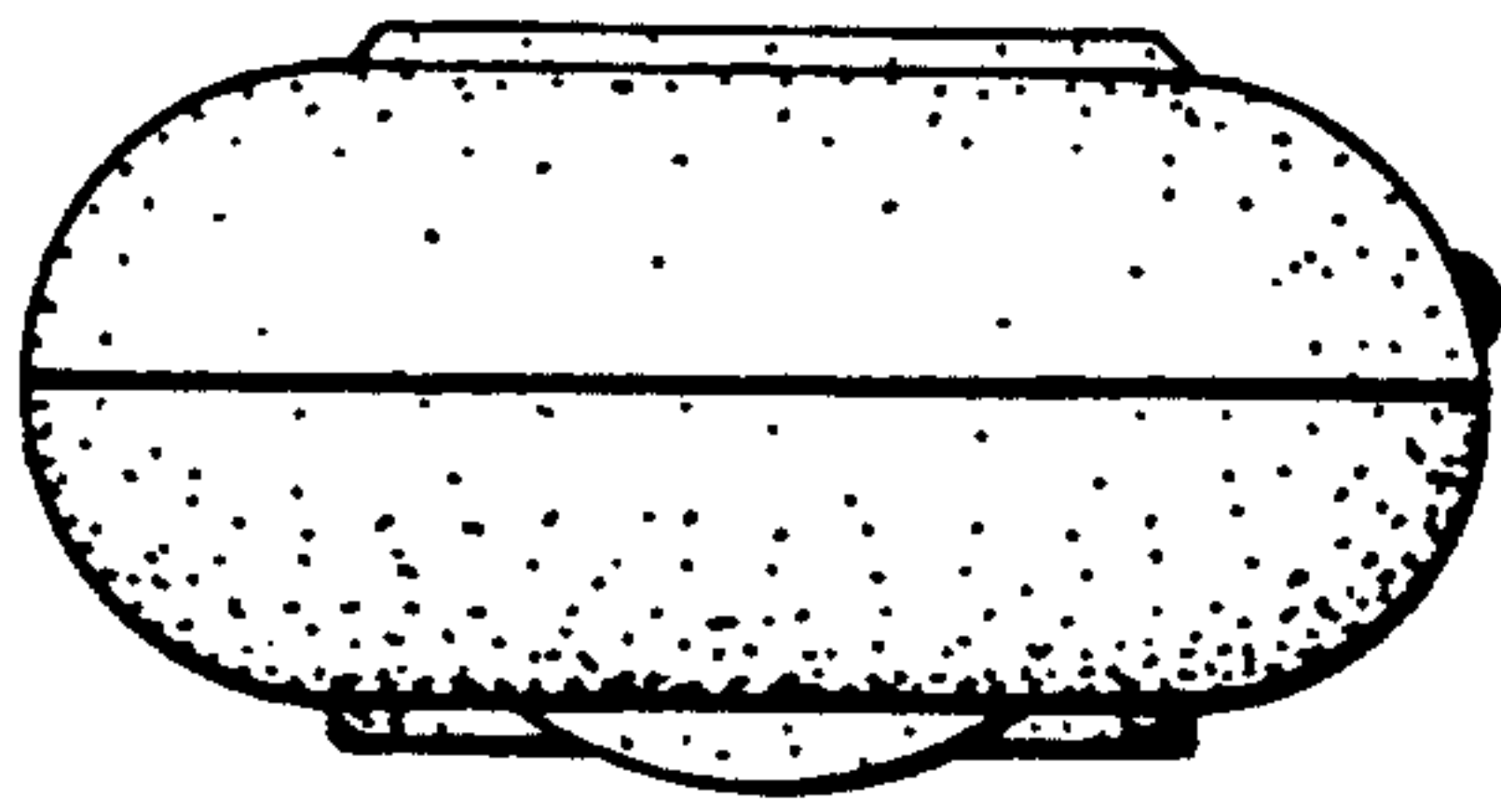

FIG. 2.

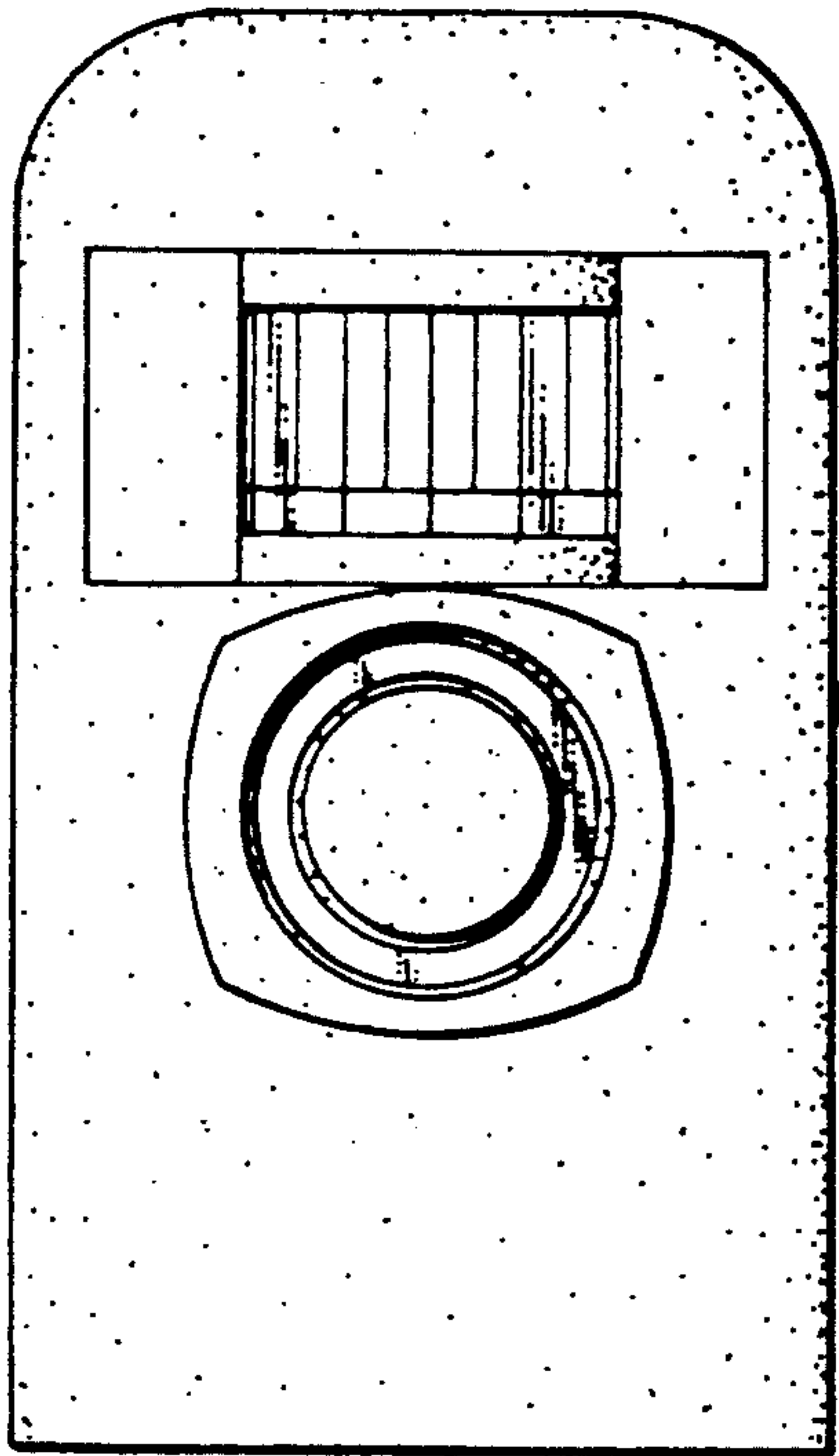

FIG. 3.

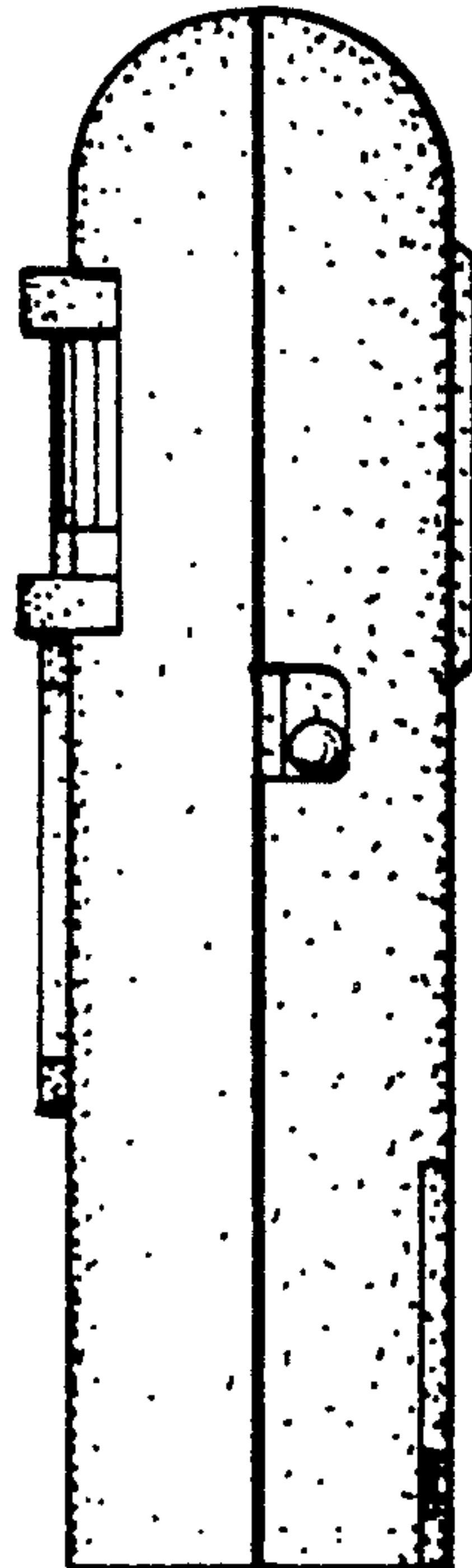

FIG. 4.

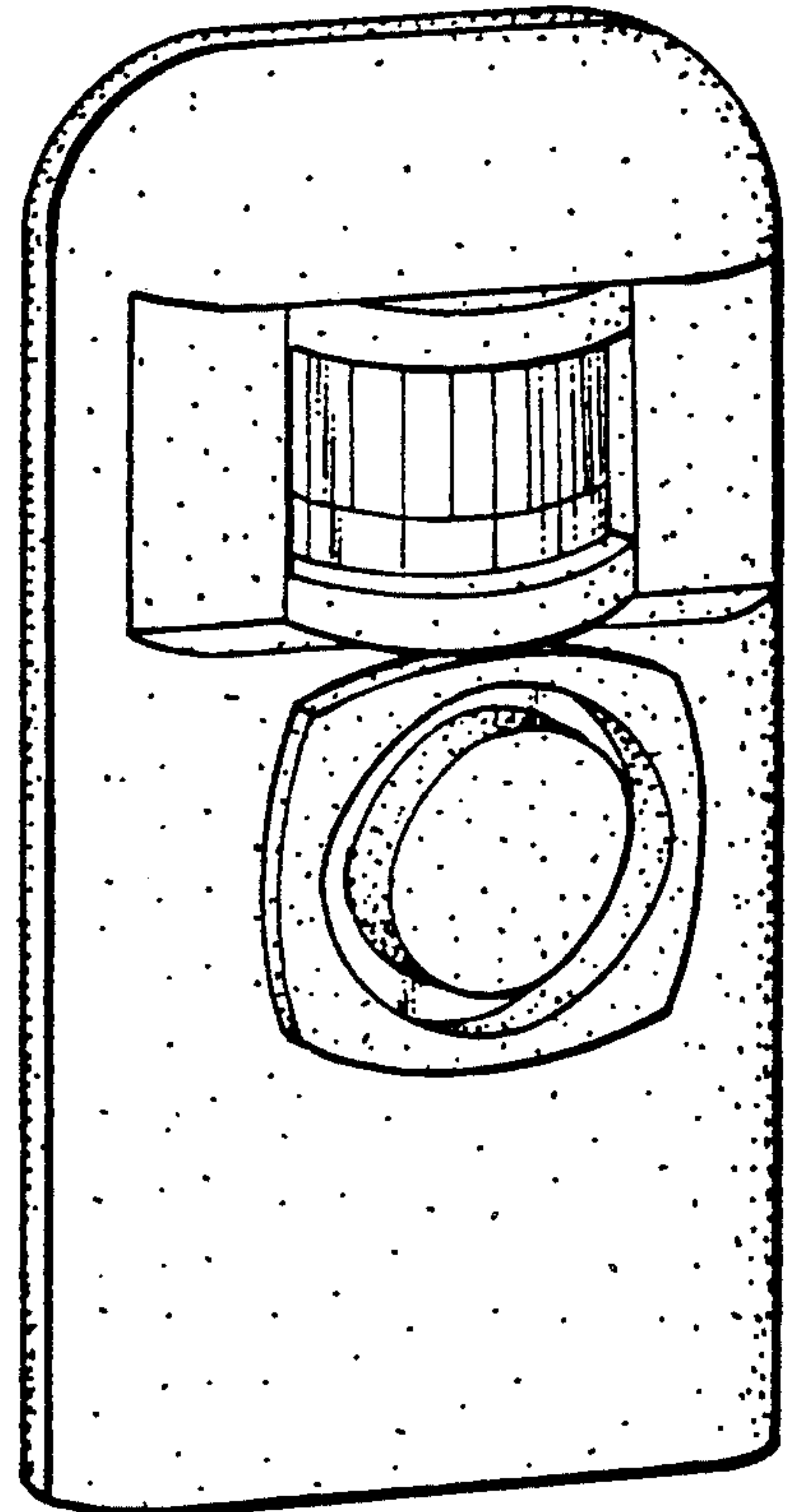

FIG. 1.

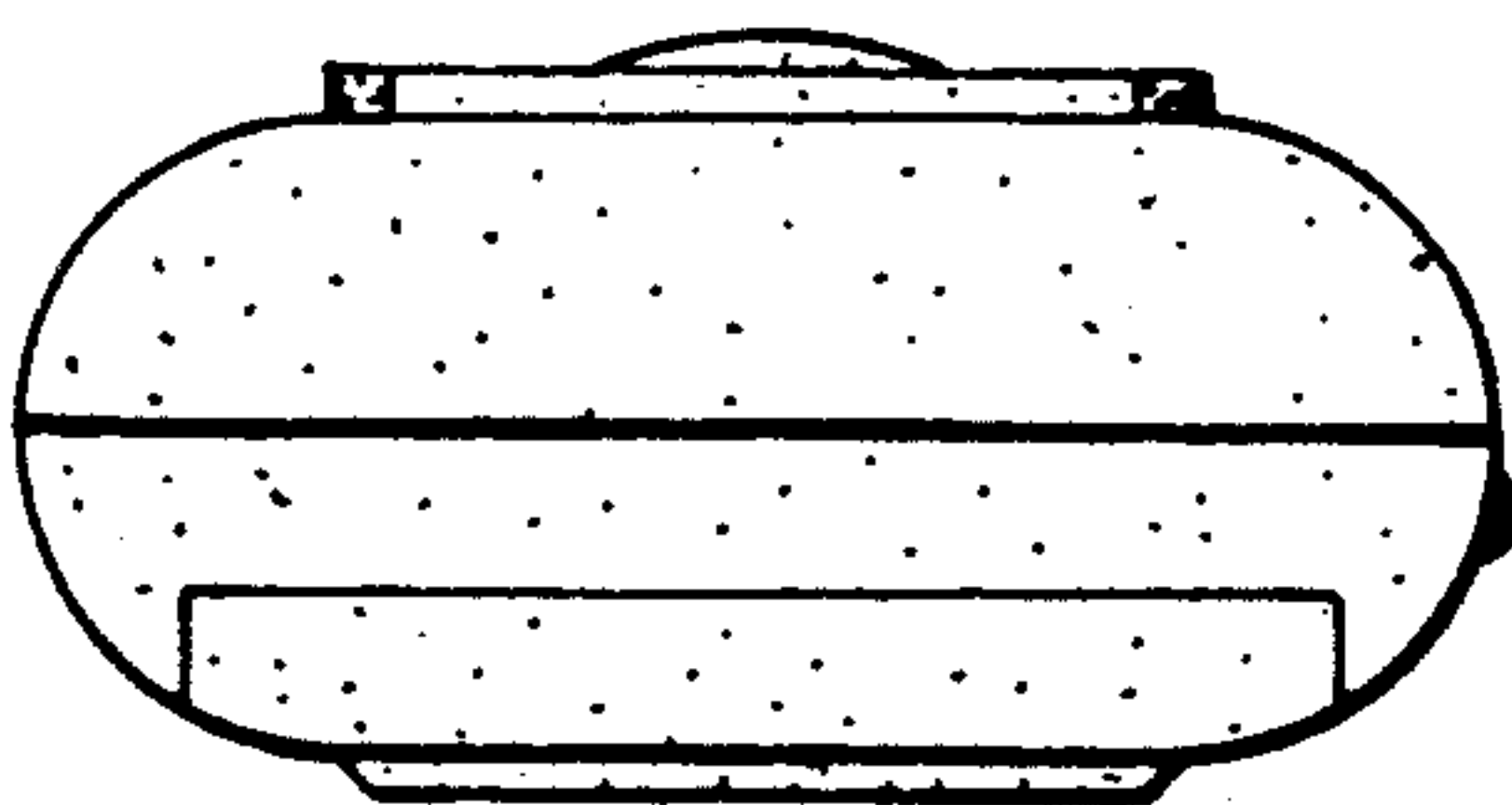

FIG. 7.

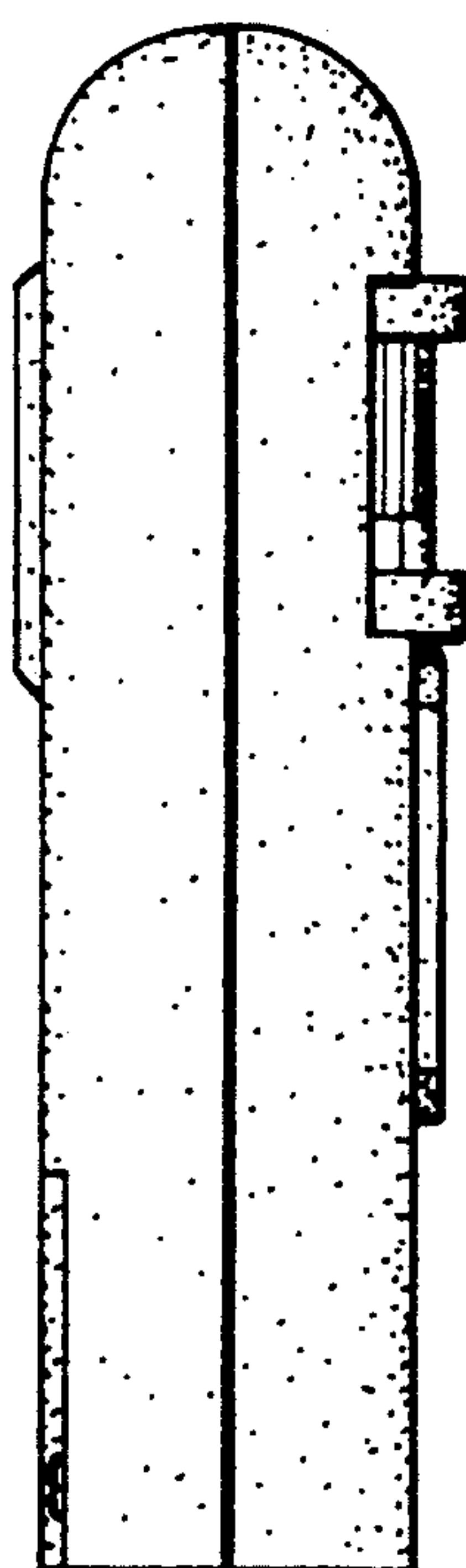

FIG. 5.

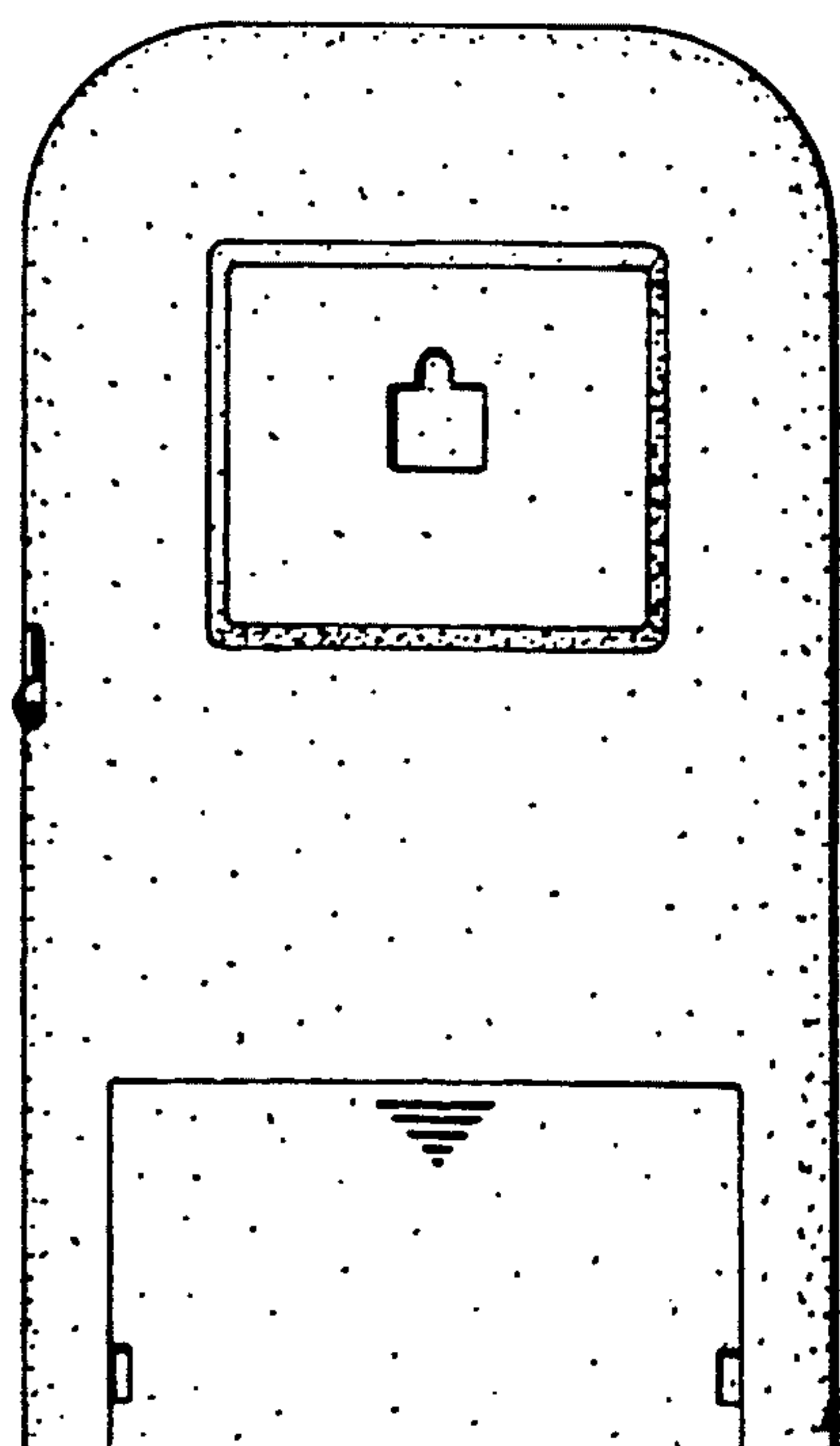

FIG. 6.

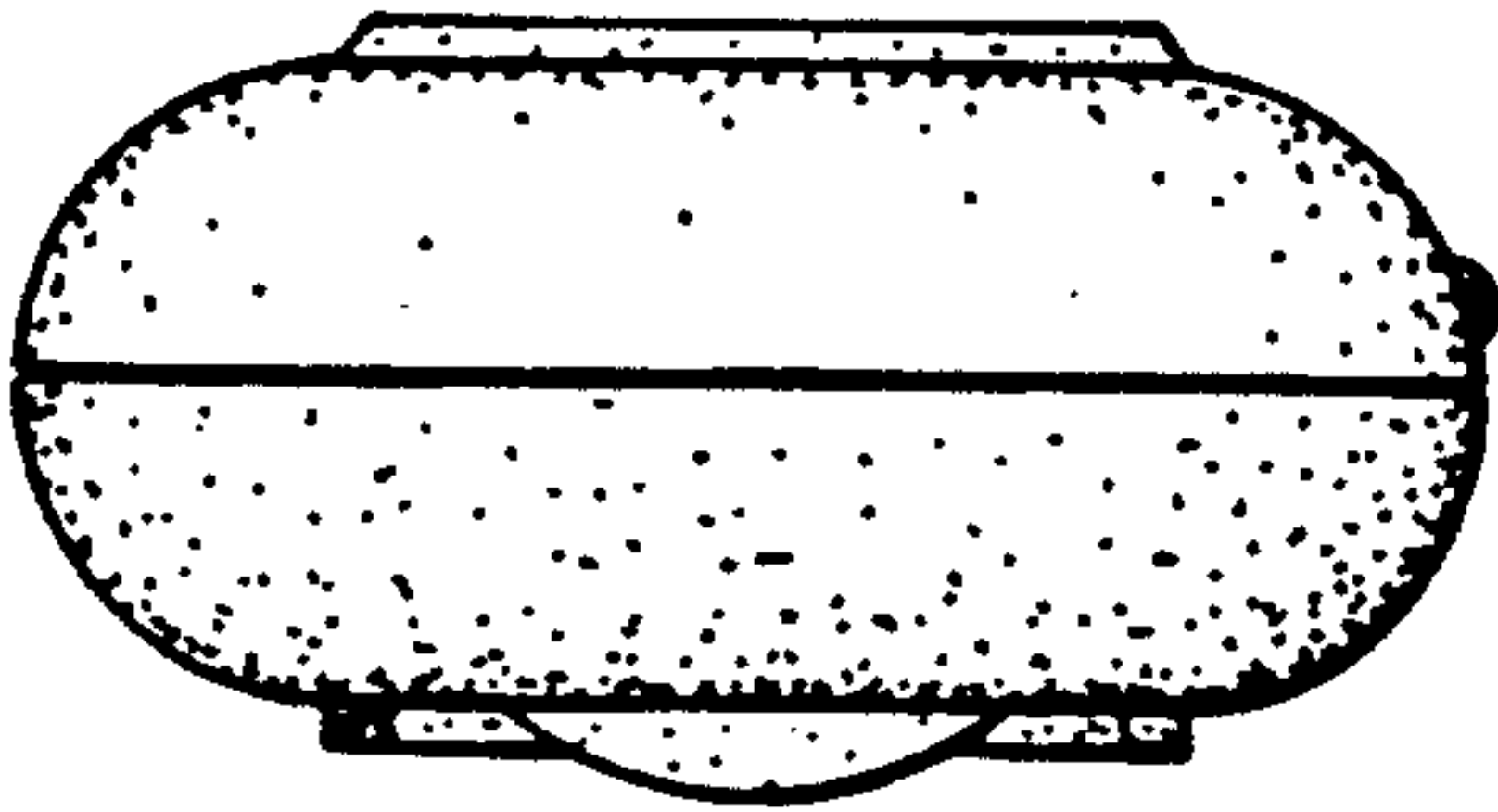

FIG. 9.

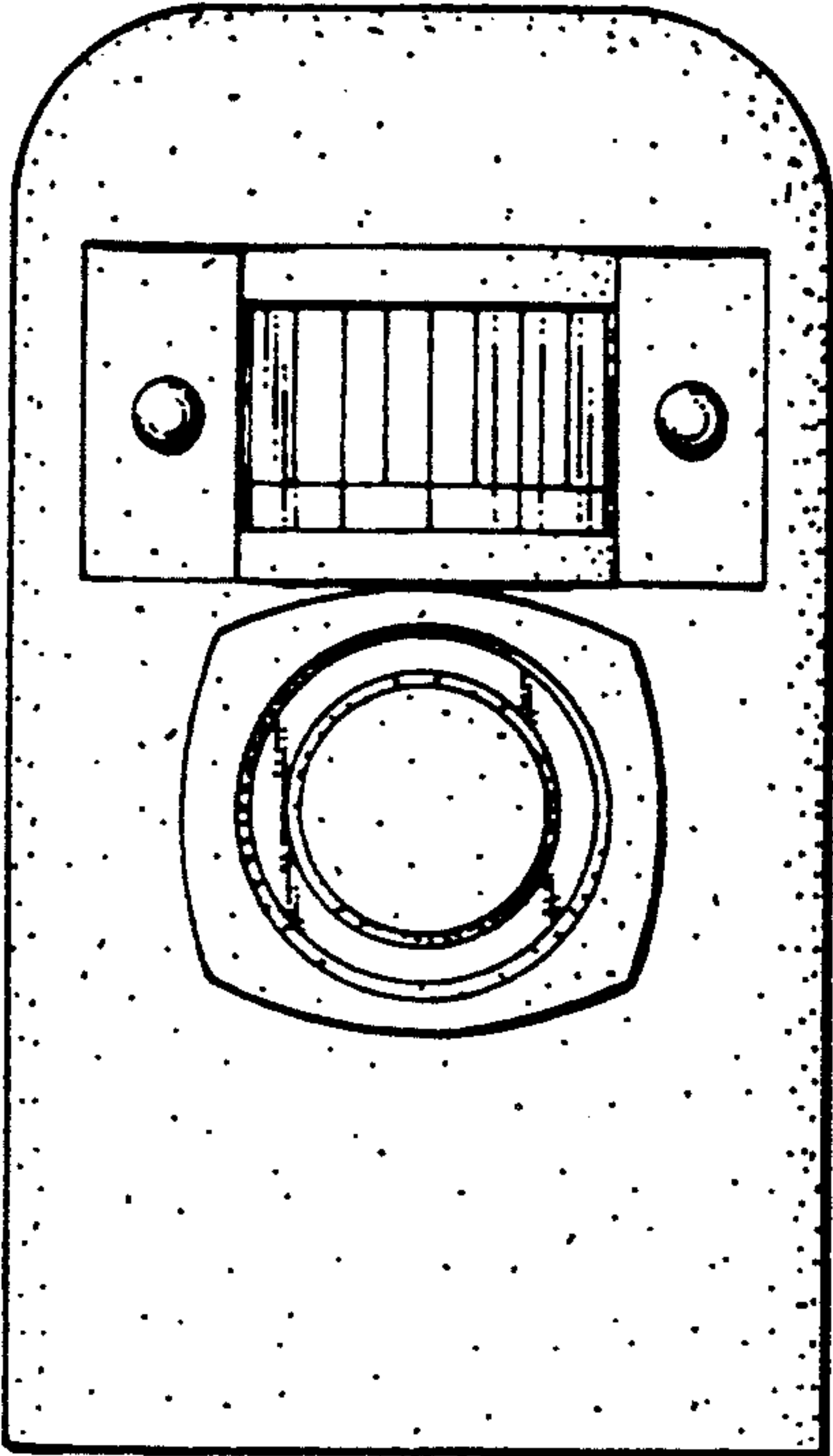

FIG. 10.

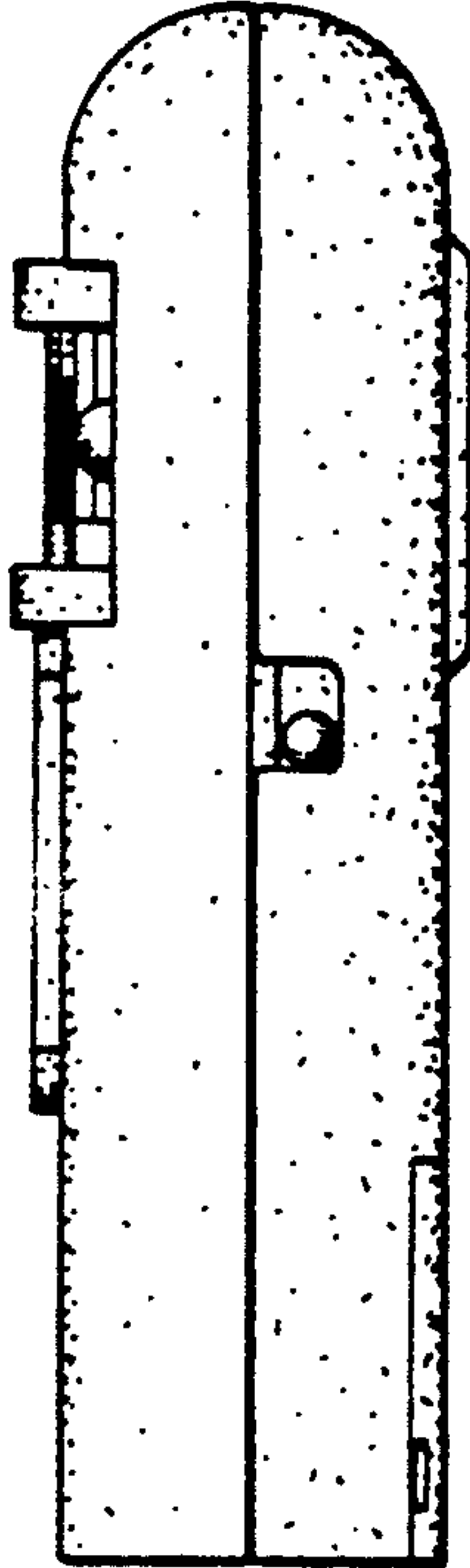

FIG. 11.

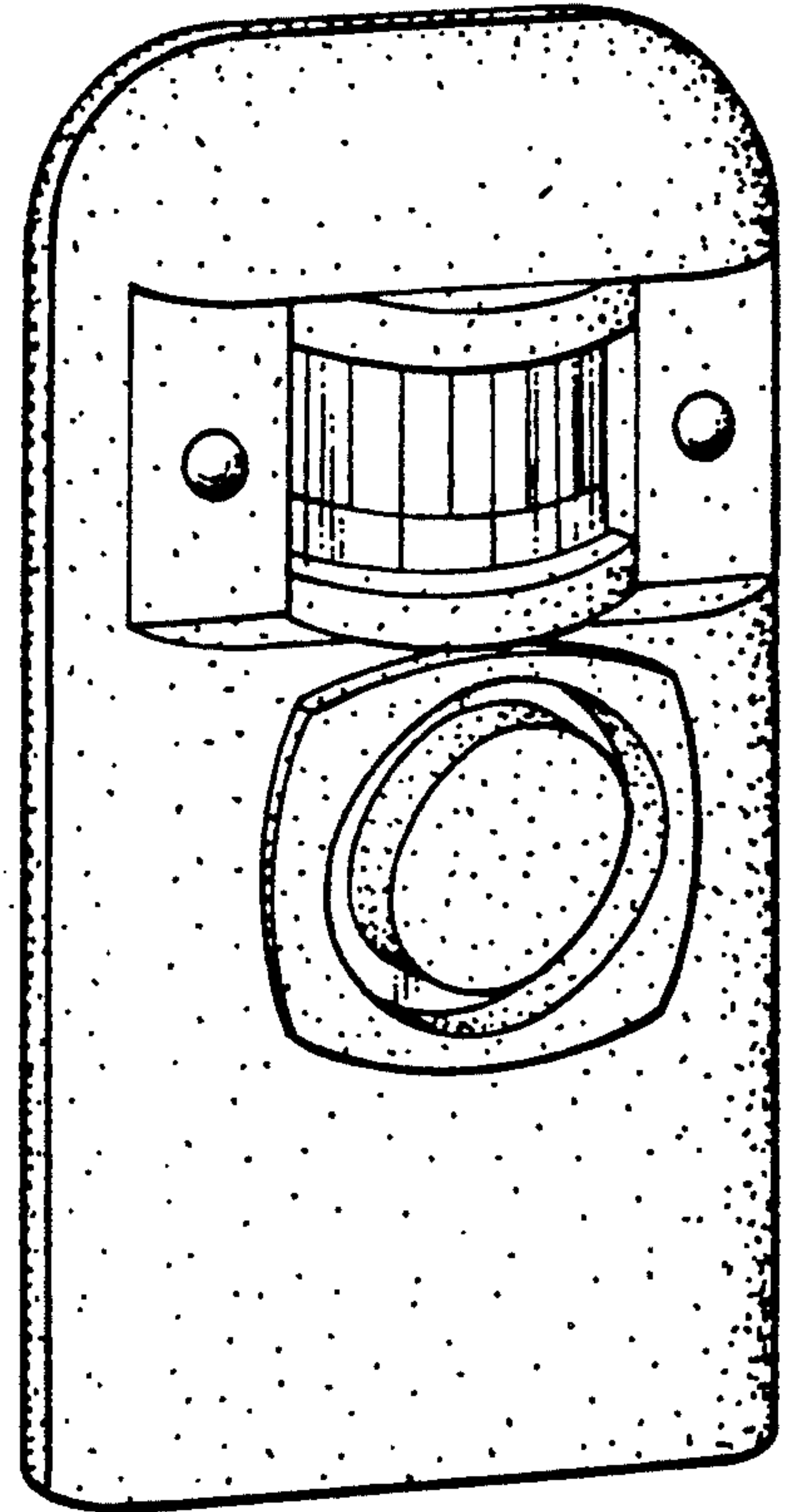

FIG. 8.

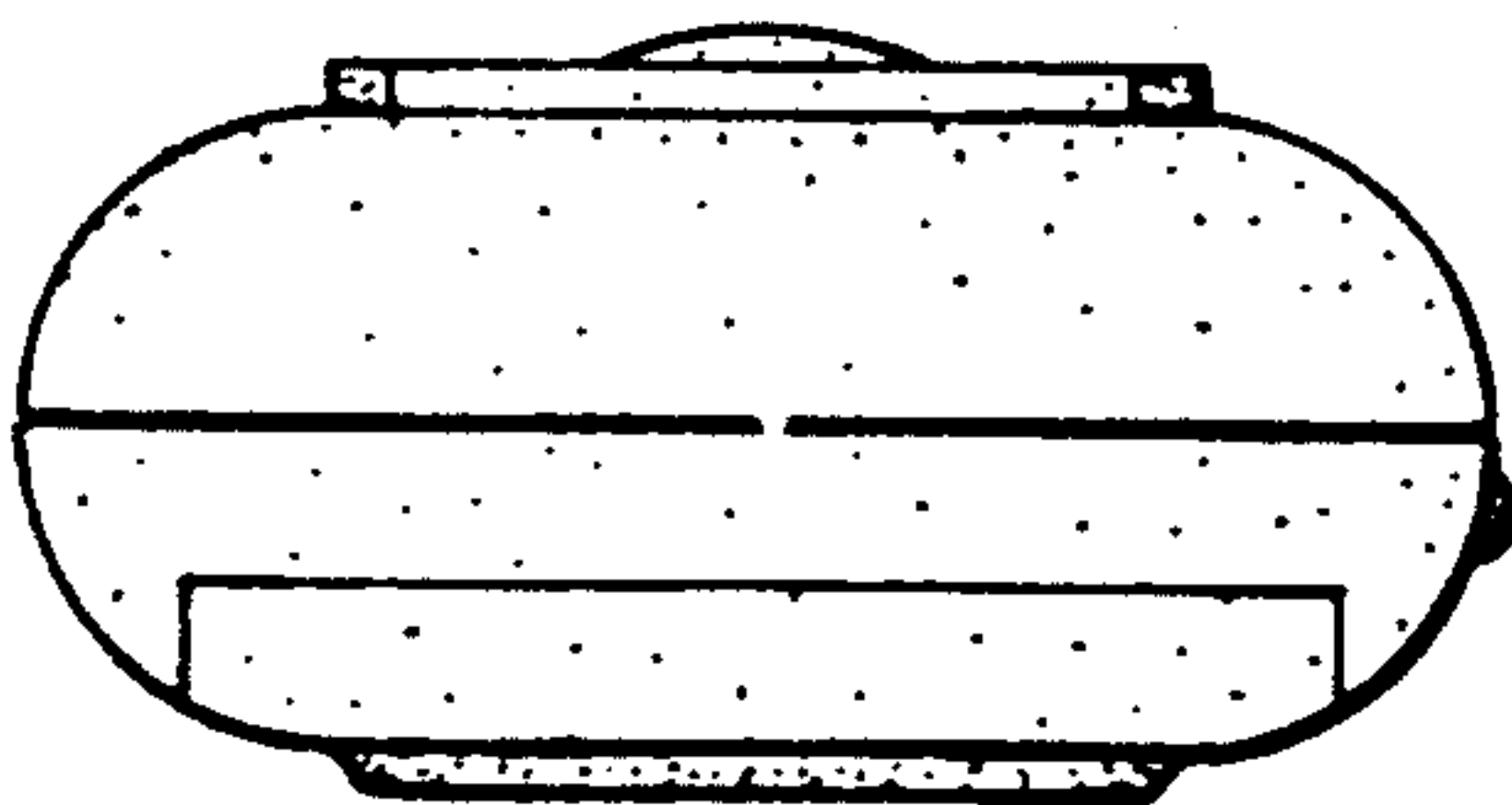

FIG. 14.

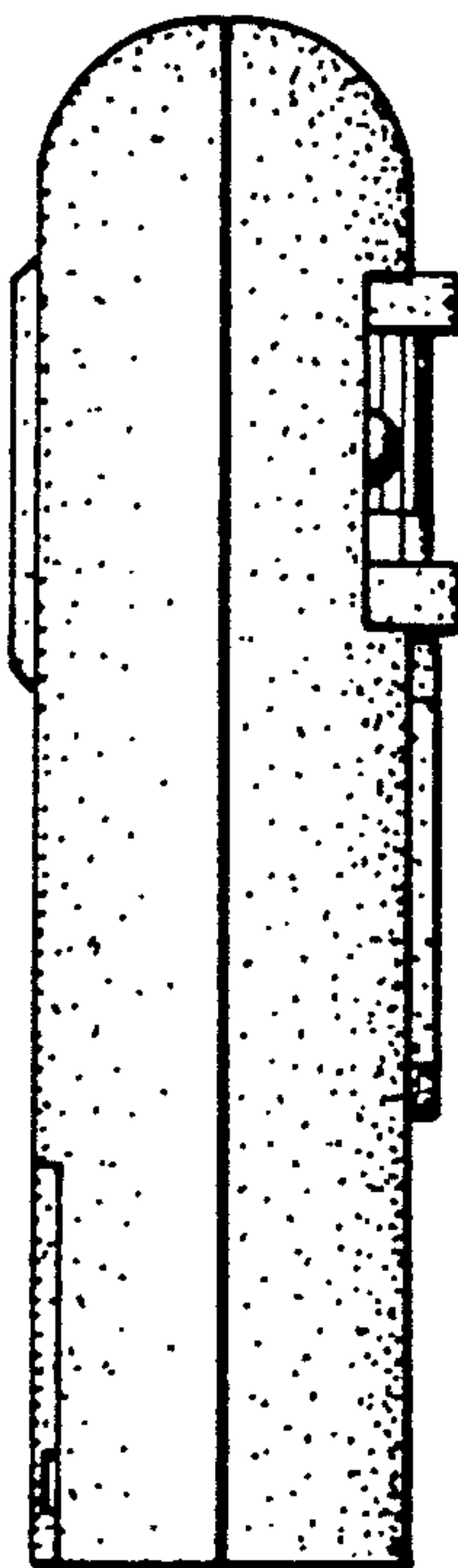

FIG. 12.

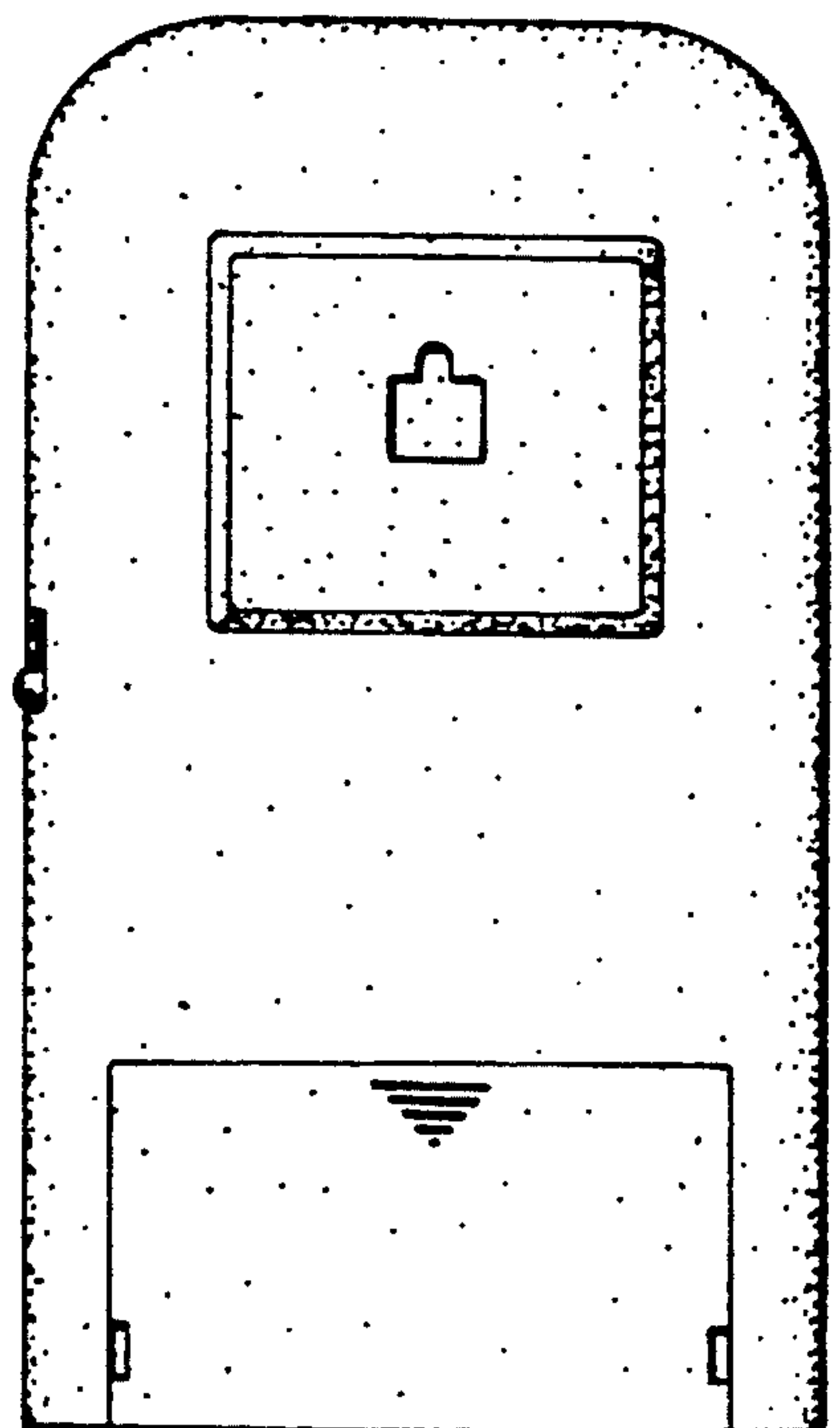

FIG. 13.