



US00D346772S

# United States Patent [19]

Godbersen

[11] Patent Number: **Des. 346,772**

[45] Date of Patent: **\*\* May 10, 1994**

[54] **PERSONAL WATERCRAFT TRAILER**

[76] Inventor: **Byron L. Godbersen, Lake LaJune Estates, Ida Grove, Iowa 51445**

[\*\*] Term: **14 Years**

[21] Appl. No.: **4,154**

[22] Filed: **Jan. 27, 1993**

[52] U.S. Cl. .... **D12/101**

[58] Field of Search ..... 280/414.1, 414.2;  
414/534; D12/101

5,060,963 10/1991 Godbersen ..... 280/414.1  
5,152,656 10/1992 Potter ..... 414/534

*Primary Examiner*—Wallace R. Burke  
*Assistant Examiner*—Melody Brown  
*Attorney, Agent, or Firm*—Henderson & Sturm

## [57] CLAIM

The ornamental design for a personal watercraft trailer, as shown and described.

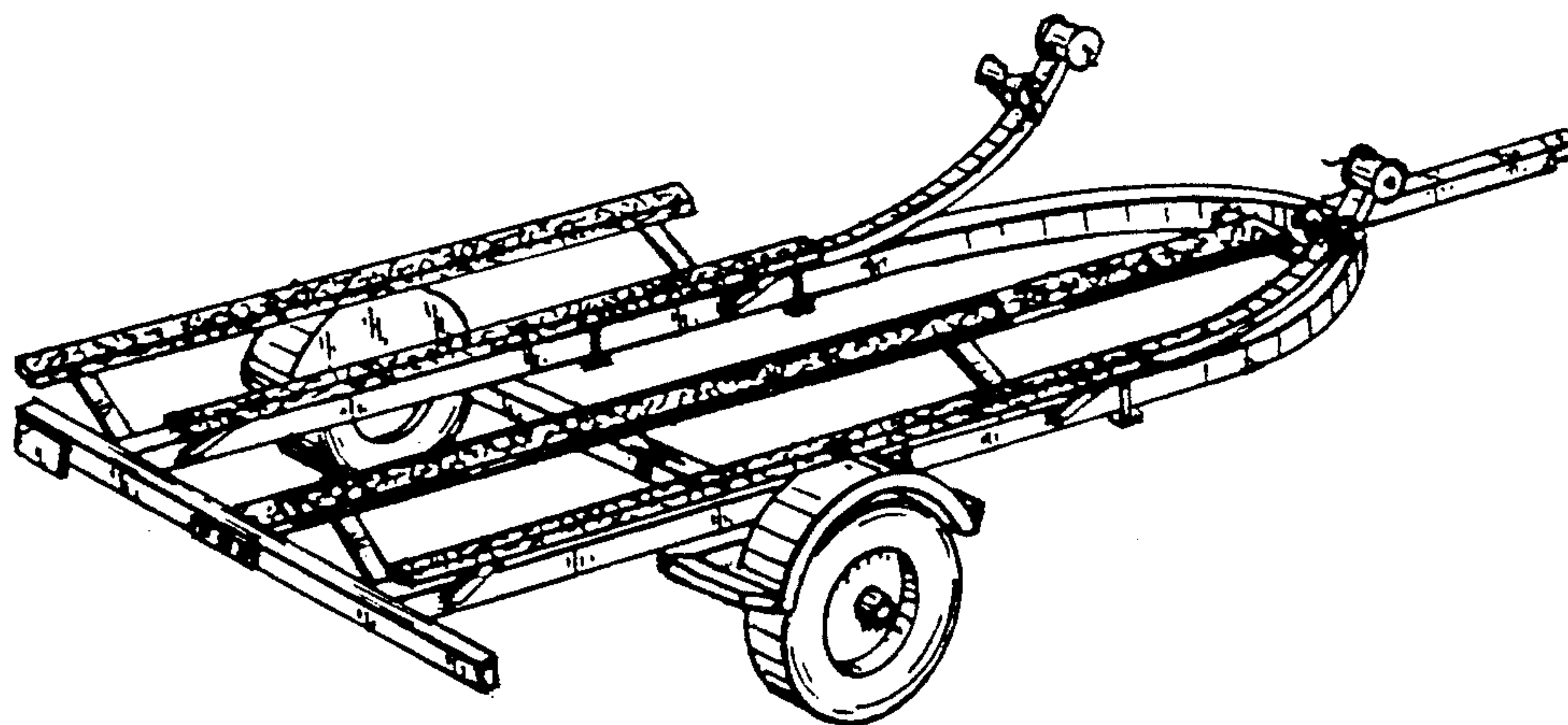
## DESCRIPTION

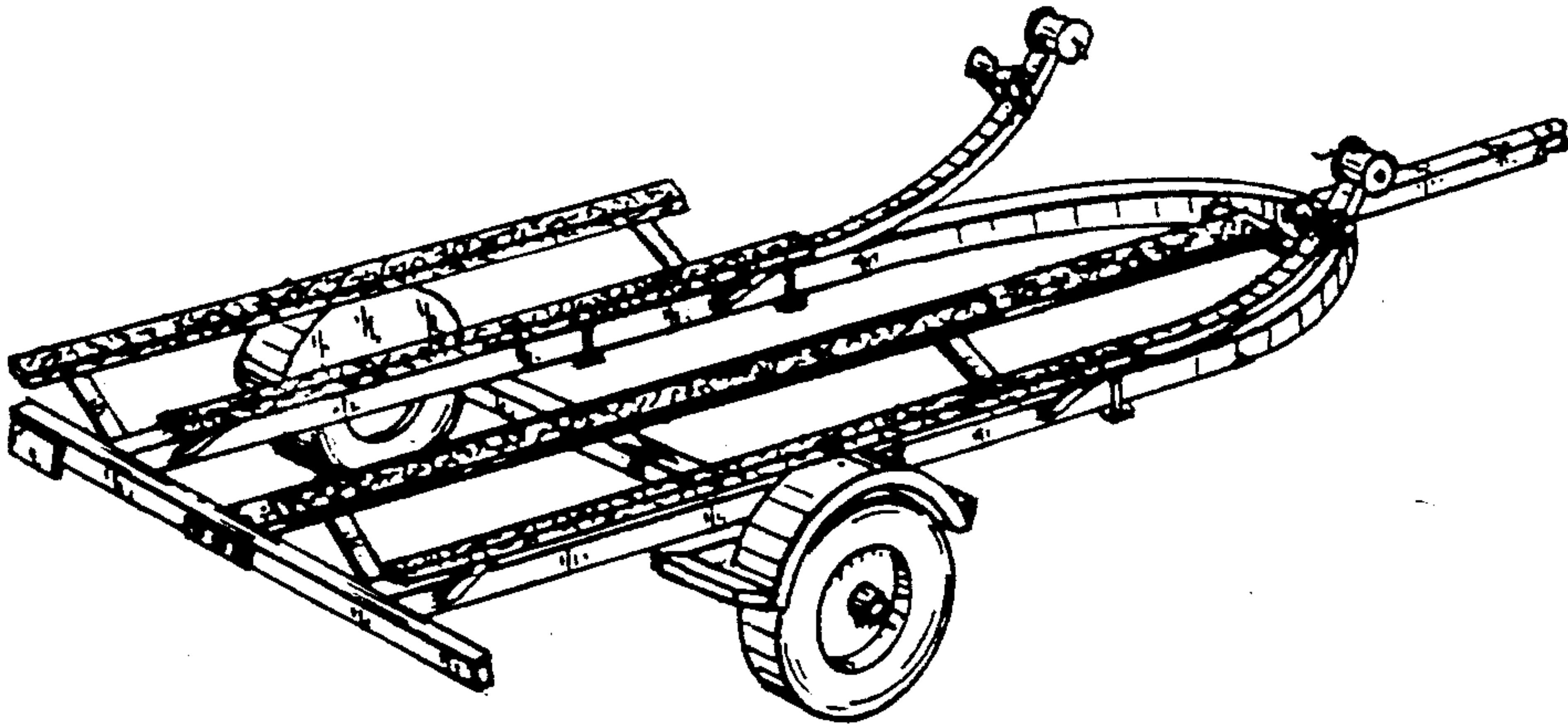
FIG. 1 is a perspective view of a personal watercraft trailer showing my new design;  
FIG. 2 is a top plan view thereof;  
FIG. 3 is a side elevational view thereof, the opposite side being a mirror image thereof;  
FIG. 4 is a front elevational view thereof; and,  
FIG. 5 is a rear elevational view thereof.

## [56] References Cited

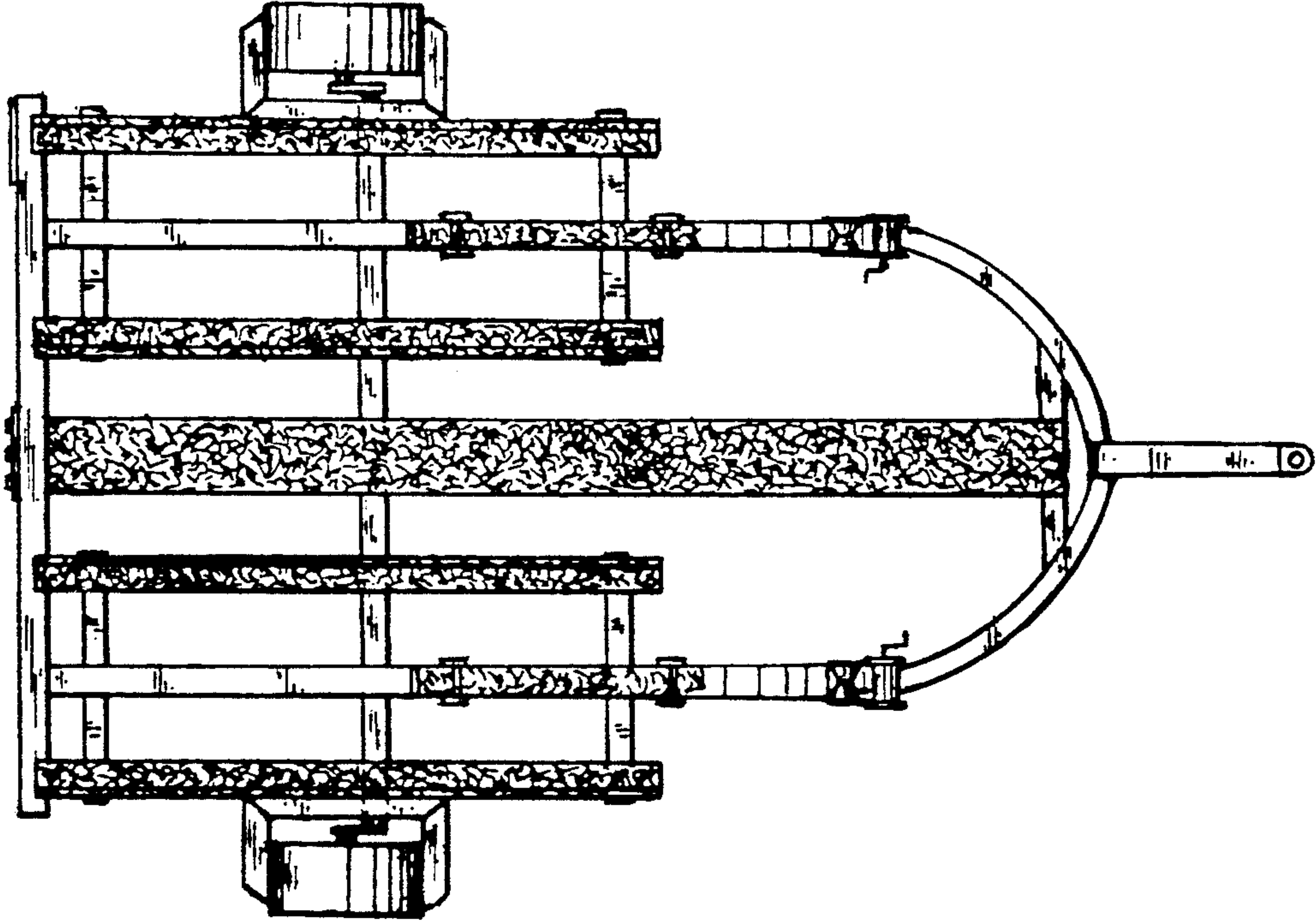
### U.S. PATENT DOCUMENTS

4,717,165 1/1988 Johnson ..... 280/414.1  
4,875,700 10/1989 Monroe ..... 280/414.1  
4,900,051 2/1990 Godbersen ..... 414/534  
5,002,299 3/1991 Firehammen et al. .... 414/534

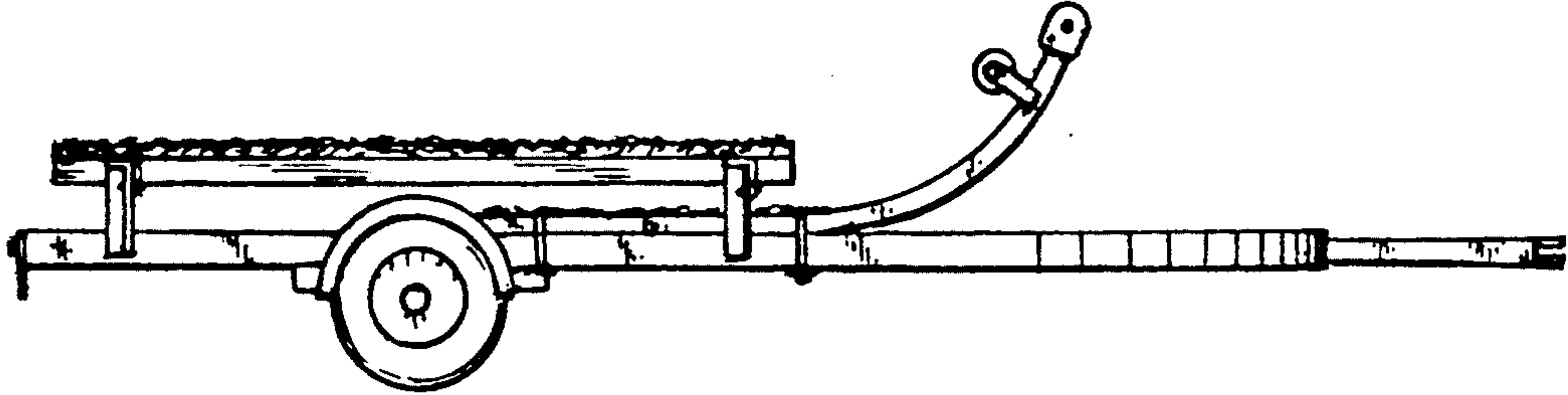




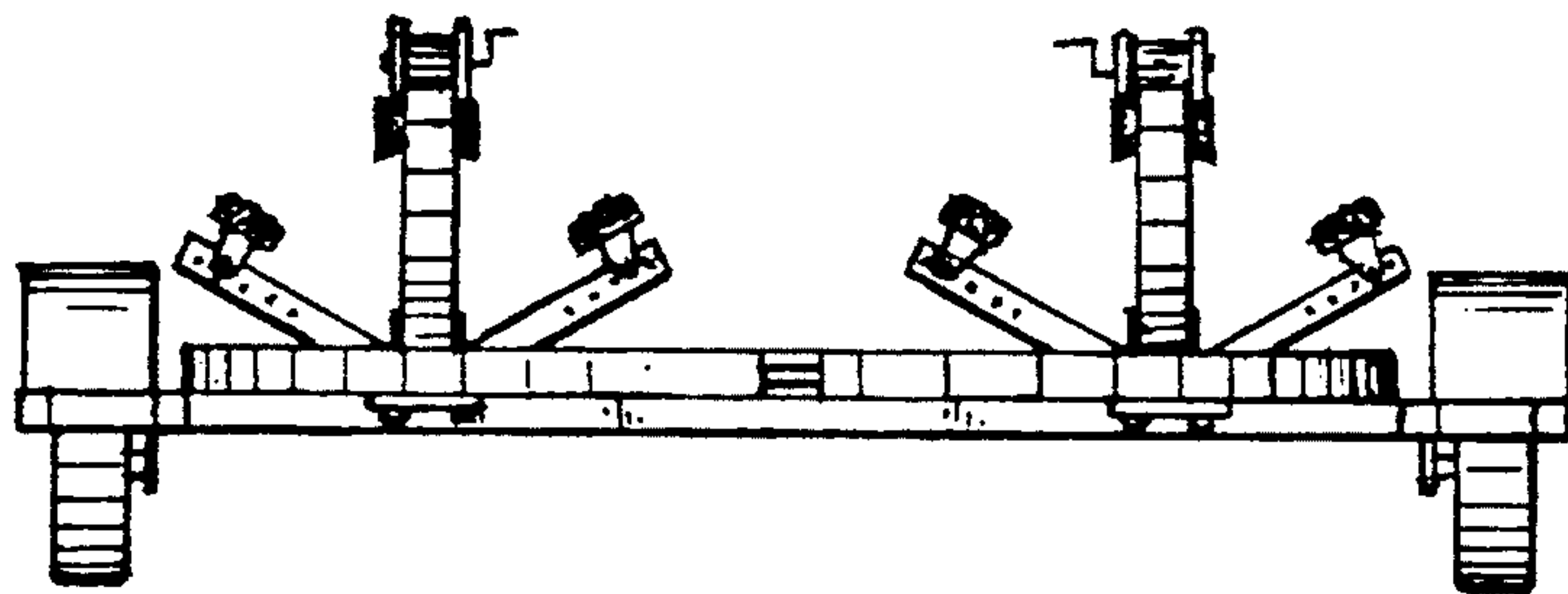
*Fig. 1*



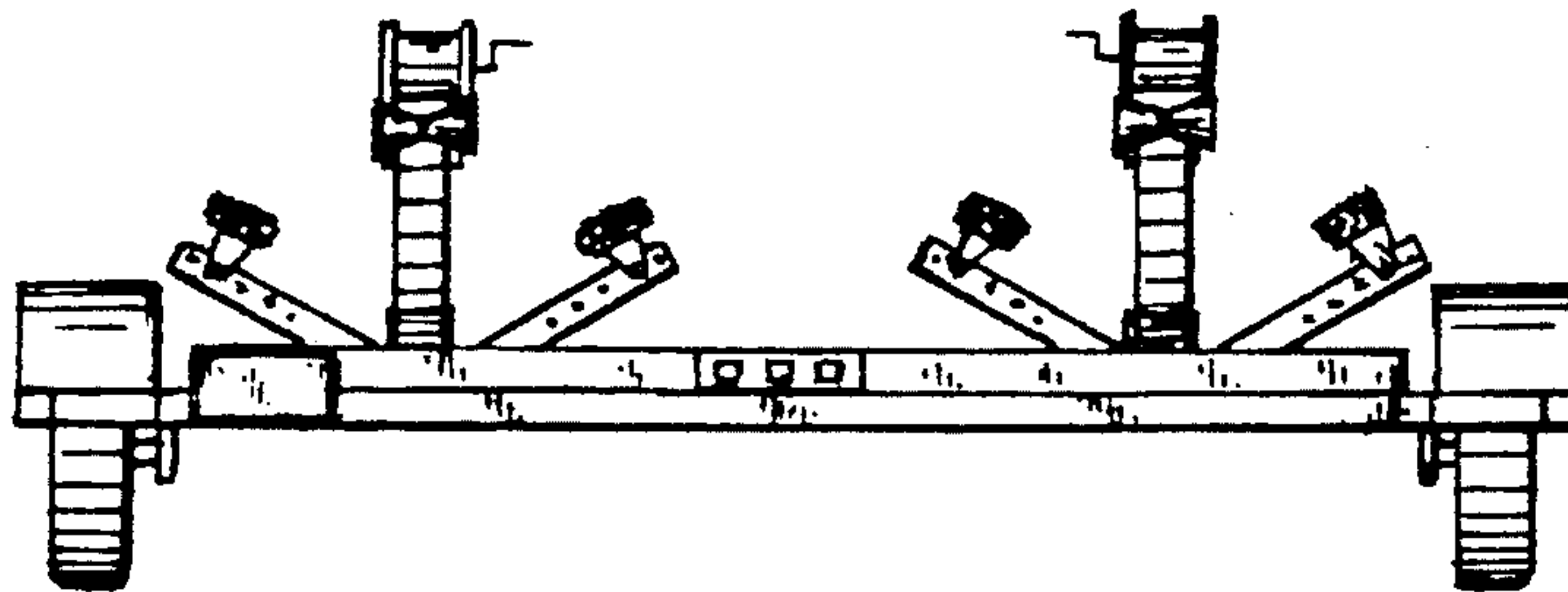
*Fig. 2*



*Fig. 3*



*Fig. 4*



*Fig. 5*