



US00D346577S

United States Patent [19]

[11] Patent Number: **Des. 346,577**

Roman

[45] Date of Patent: **** May 3, 1994**

[54] **AUTOMOBILE FENDER SKIRT**

2,832,609 4/1958 Buckenhizer 280/848

[75] Inventor: **Jerry Roman**, Avon Lake, Ohio

Primary Examiner—Wallace R. Burke

[73] Assignee: **Roman Chariot, Inc.**, Cleveland, Ohio

Assistant Examiner—Melody Brown

Attorney, Agent, or Firm—Ray, Sharpe, Beall, Fagan, Minnich & McKee

[**] Term: **14 Years**

[57] **CLAIM**

[21] Appl. No.: **68**

The ornamental design for an automobile fender skirt, as shown and described.

[22] Filed: **Oct. 1, 1992**

[52] U.S. Cl. **D12/184**

DESCRIPTION

[58] Field of Search 280/848, 849, 851, 152.1; D12/184, 190

FIG. 1 is a front elevational view of an automobile fender skirt showing my new design;

FIG. 2 is a top plan view thereof;

FIG. 3 is a side elevational view thereof;

FIG. 4 is an opposite side elevational view thereof;

FIG. 5 is a rear elevational view thereof; and,

FIG. 6 is a bottom plan view thereof.

The broken lines shown in FIGS. 1, 2, 3, 5 and 6.

[56] **References Cited**

U.S. PATENT DOCUMENTS

- D. 299,019 12/1988 McKinnan D12/184
- D. 321,160 10/1991 Kingsley D12/184
- D. 321,161 10/1991 Ueno D12/184

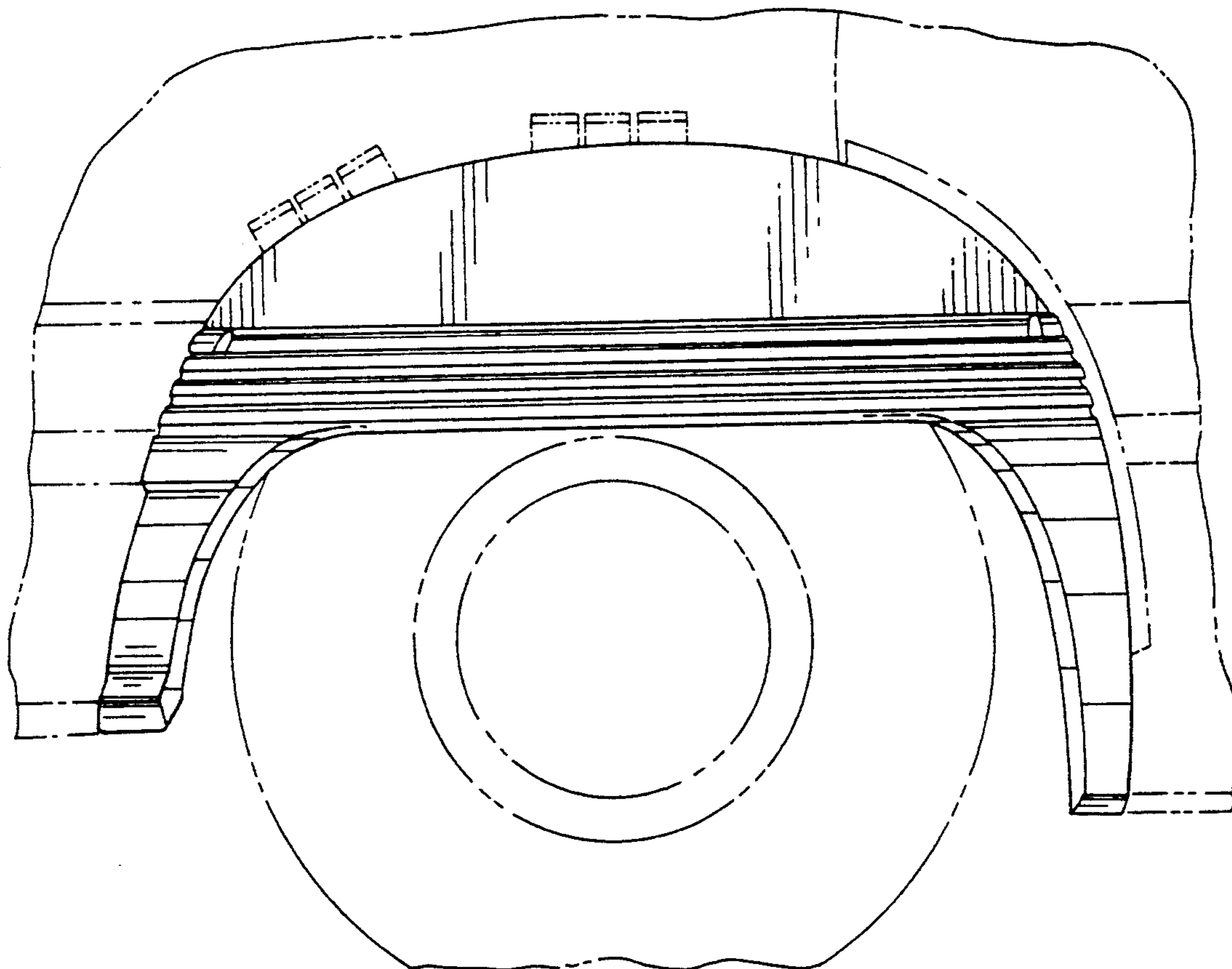

FIG. 2

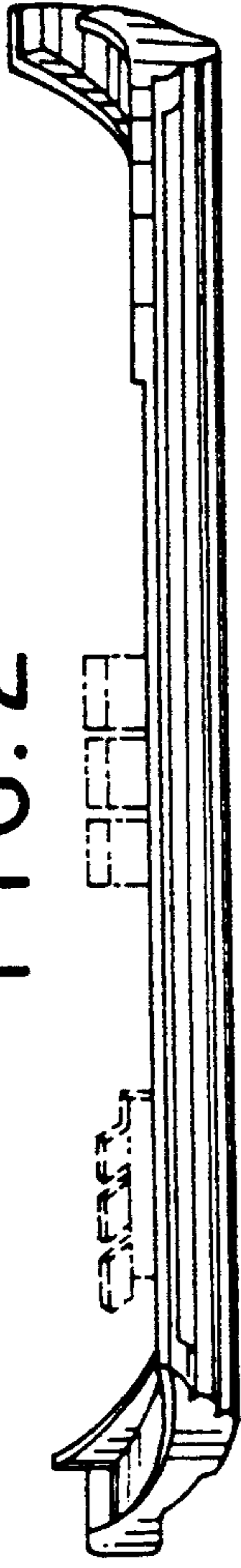

FIG. 3

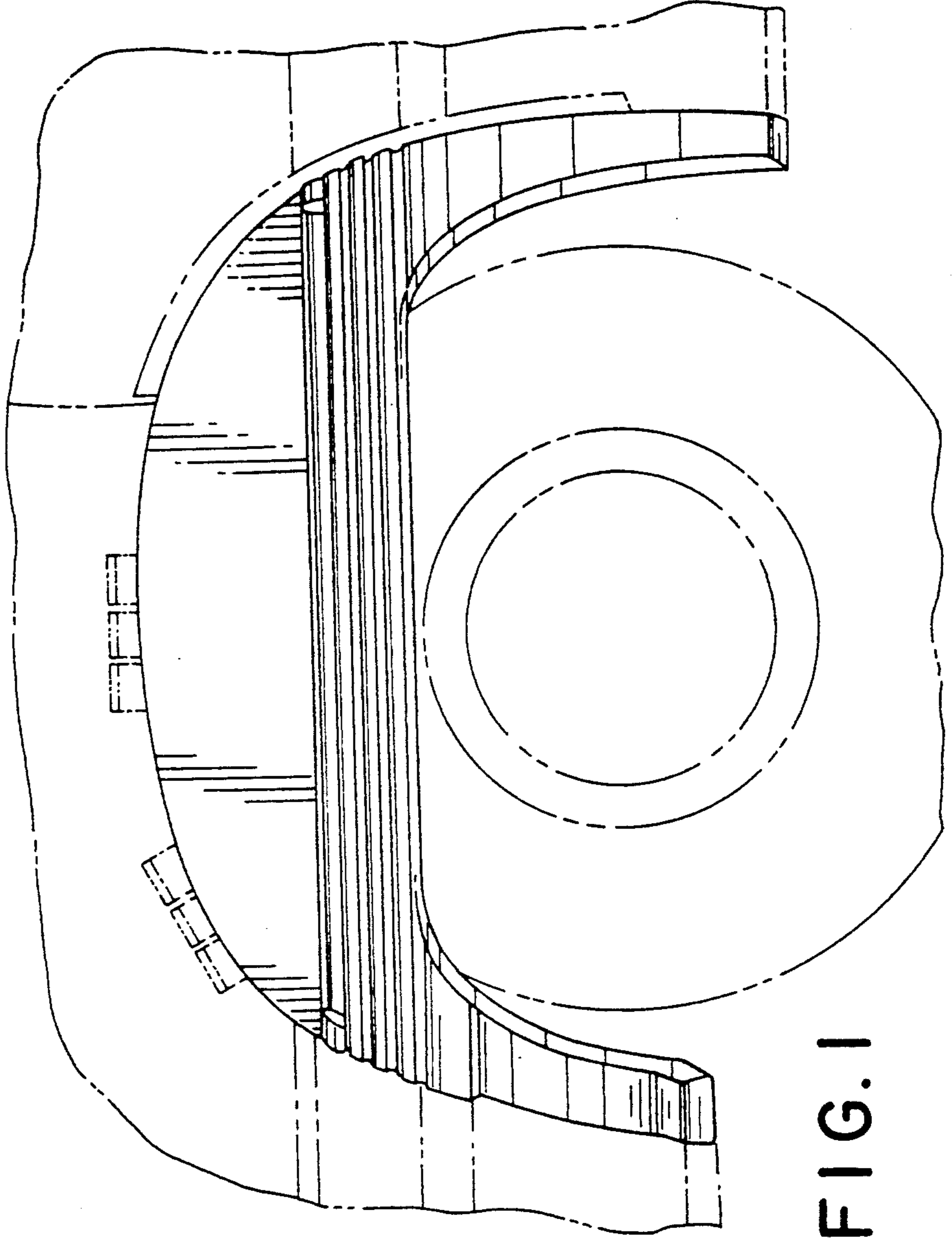
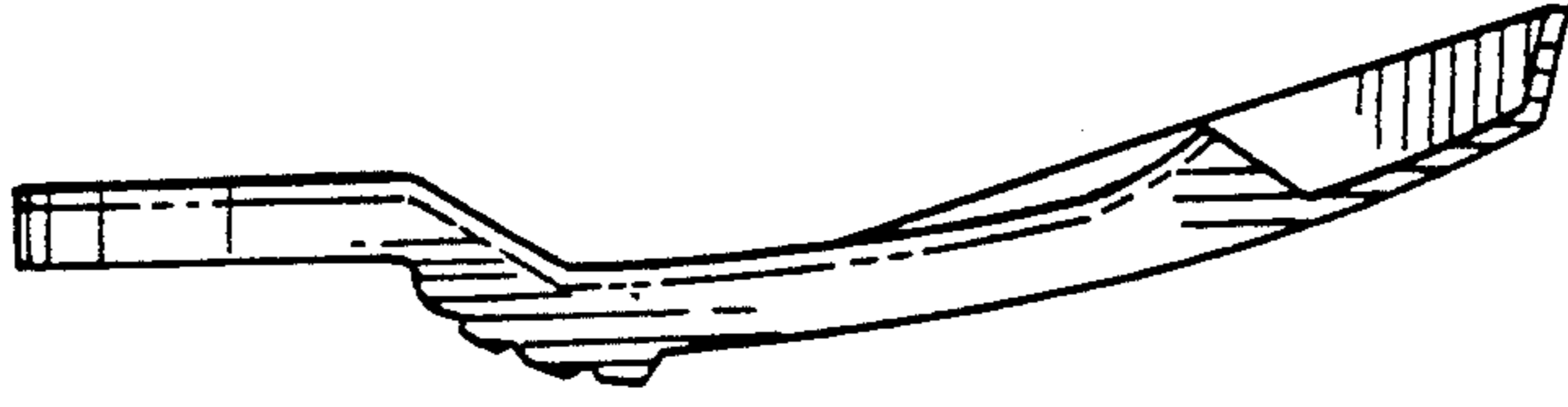

FIG. 1

FIG. 4

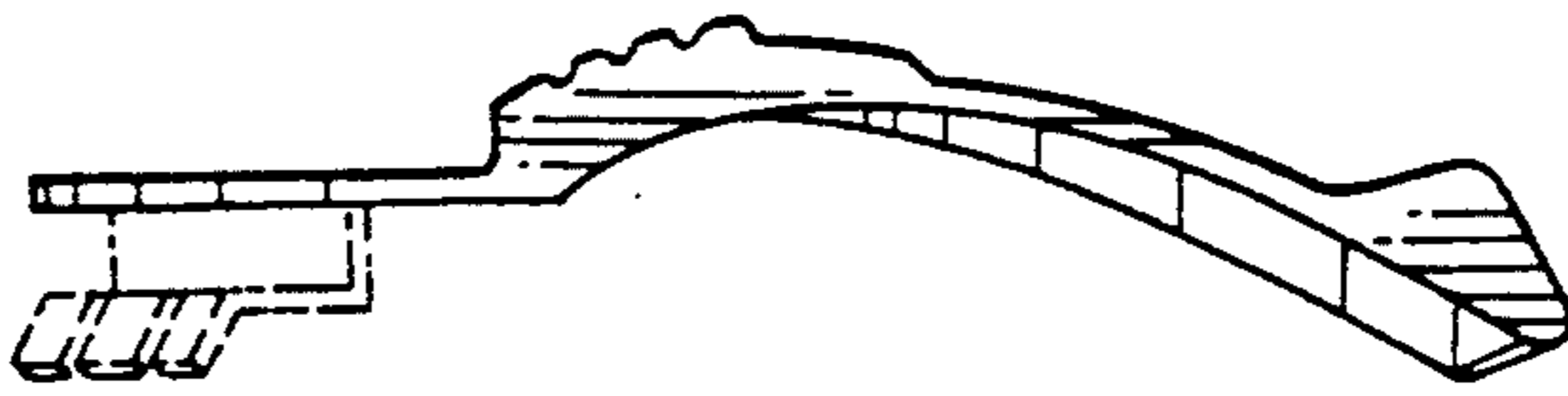

FIG. 5

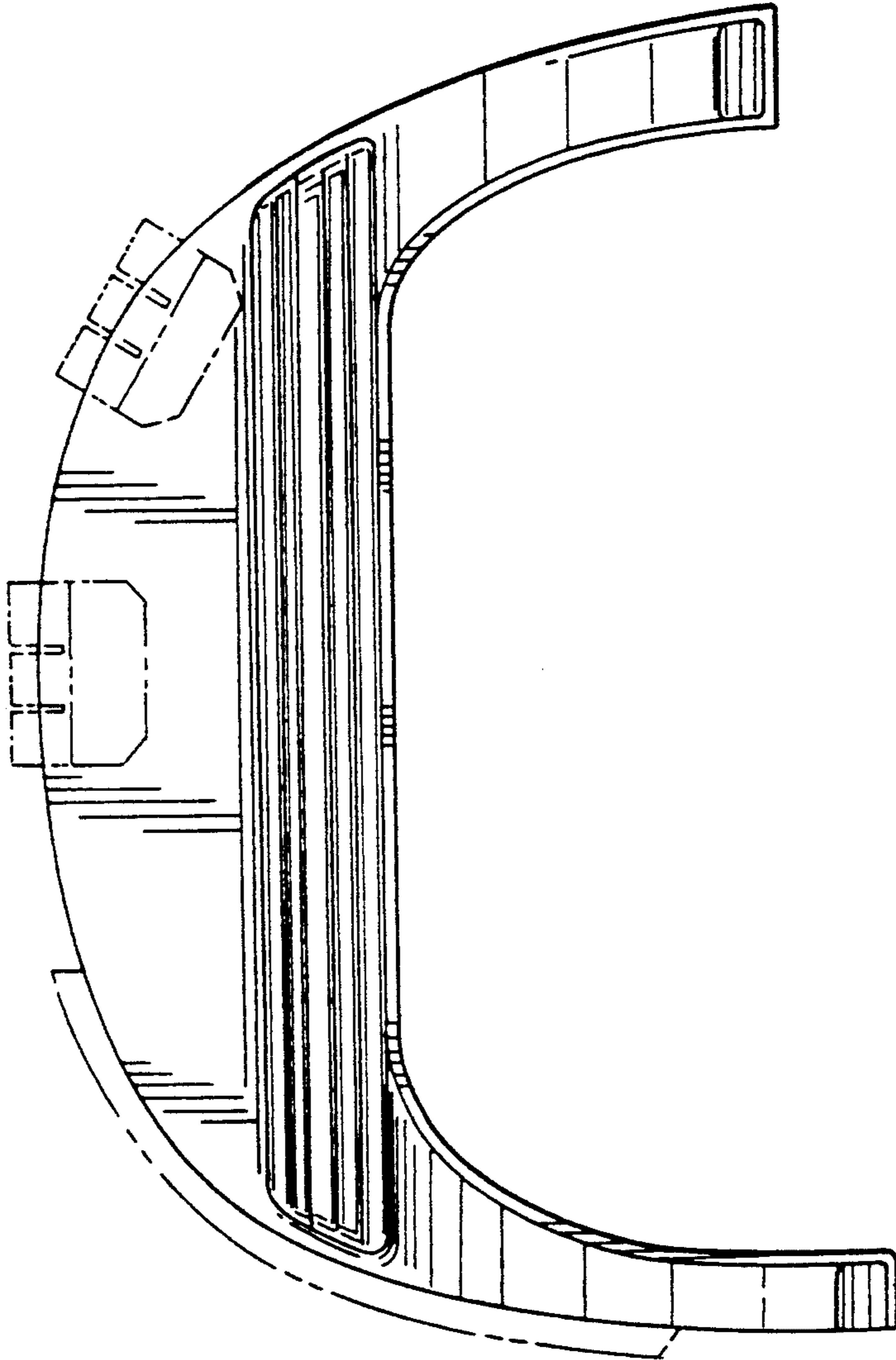

FIG. 6

