



US00D346576S

United States Patent [19]

[11] Patent Number: **Des. 346,576**

Steer et al.

[45] Date of Patent: **** May 3, 1994**

[54] **REAR PARTITION FOR A TANDEM BRAKE BOOSTER**

4,447,897 5/1984 Boehm 91/369.4
5,076,142 12/1991 Steer et al. 91/369.3

[75] Inventors: **John E. Steer, Forest, Va.; Thomas M. O'Brien, Buchanan, Mich.; Thomas E. Dodd, South Bend, Ind.; Jon R. Dodson, Niles, Mich.; Louis P. Rossigno, Granger, Ind.**

Primary Examiner—Wallace R. Burke
Assistant Examiner—Melody Brown
Attorney, Agent, or Firm—Leo H. McCormick, Jr.; Ken C. Decker

[73] Assignee: **Allied-Signal Inc., Morristown, N.J.**

[**] Term: **14 Years**

[57] **CLAIM**

The ornamental design for a rear partition plate for a tandem brake booster, as shown and described.

[21] Appl. No.: **997,627**

DESCRIPTION

[22] Filed: **Dec. 28, 1992**

[52] U.S. Cl. **D12/180**

[58] Field of Search 91/369.3, 369.1, 369.2, 91/369.4; D12/180

FIG. 1 is a front elevation view of a rear partition plate for a tandem brake booster showing our new design; FIG. 2 is a side elevational view thereof, the opposite side being a mirror image of that shown; FIG. 3 is a rear elevational view of thereof; FIG. 4 is a front perspective view of the partition plate of FIG. 1; and, FIG. 5 is a rear perspective view of the partition plate of FIG. 1.

[56] **References Cited**

U.S. PATENT DOCUMENTS

4,366,744 1/1983 Katagiri et al. 91/369.1

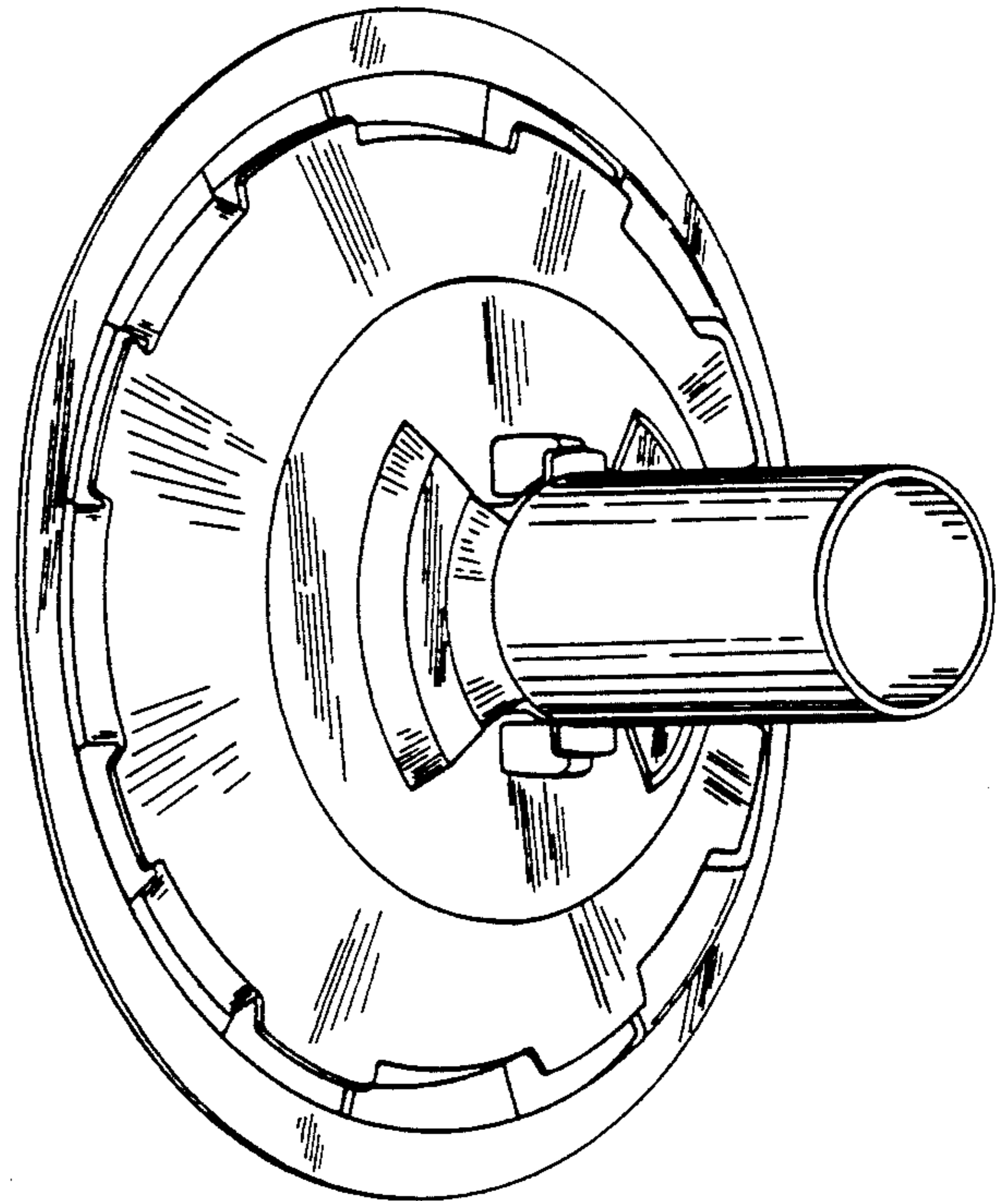
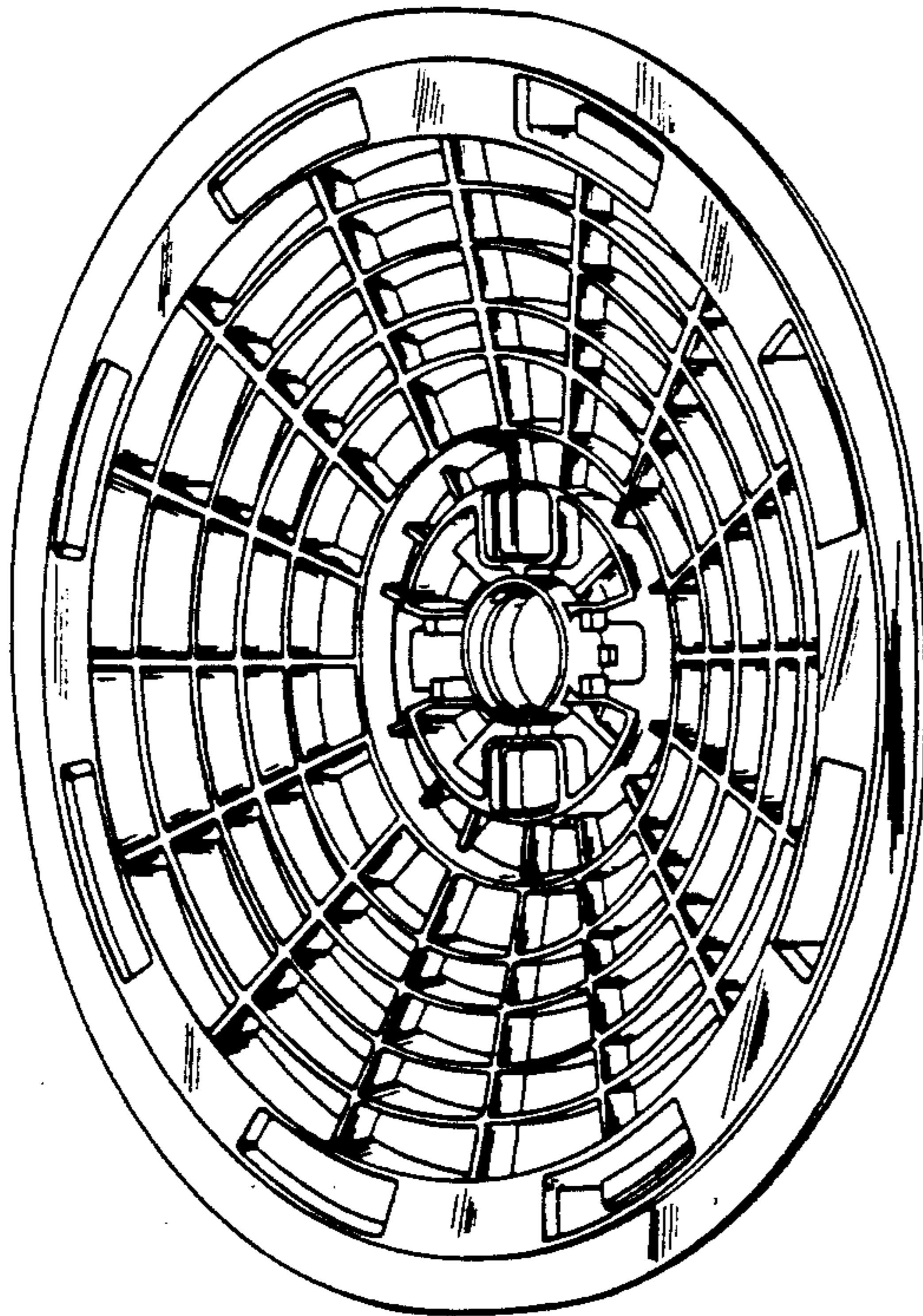

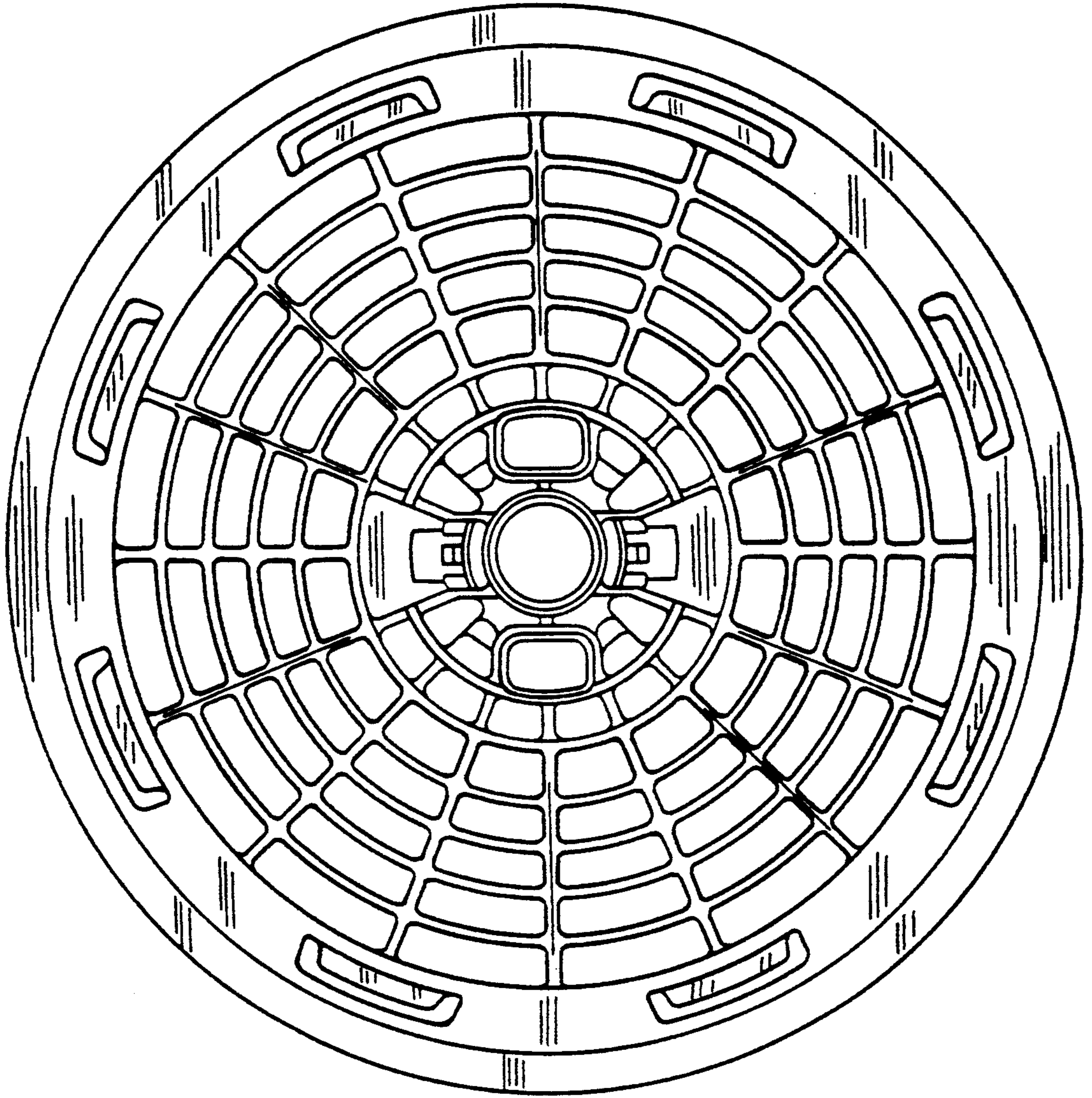

FIG. 1

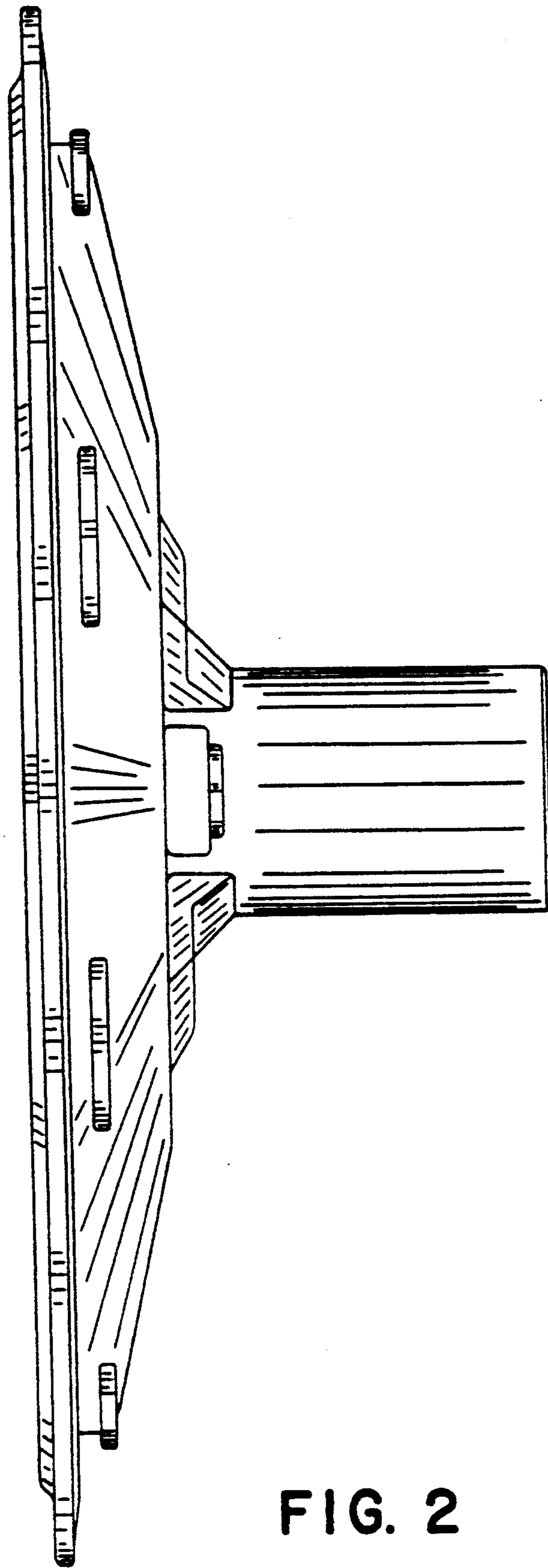

FIG. 2

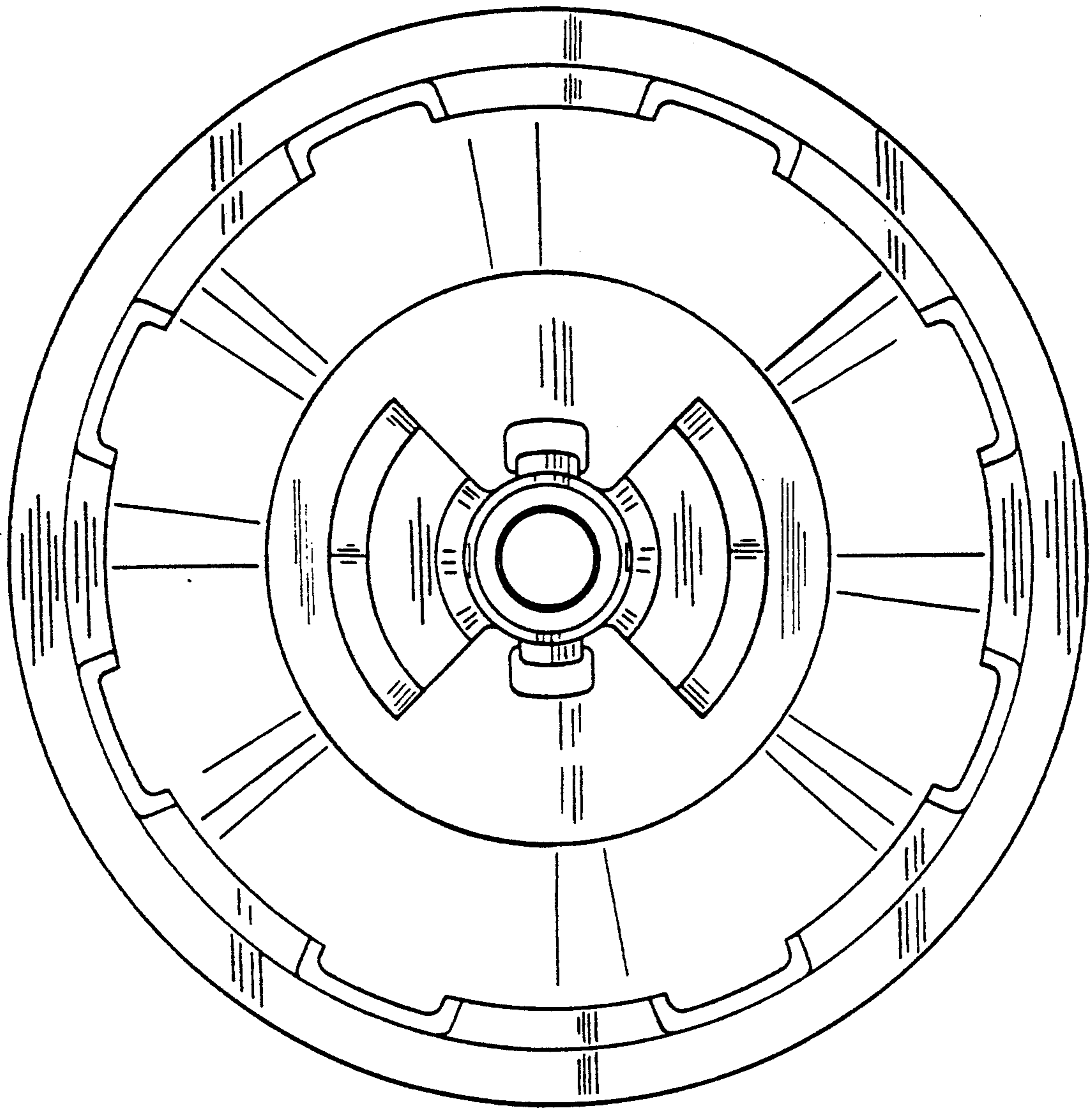

FIG. 3

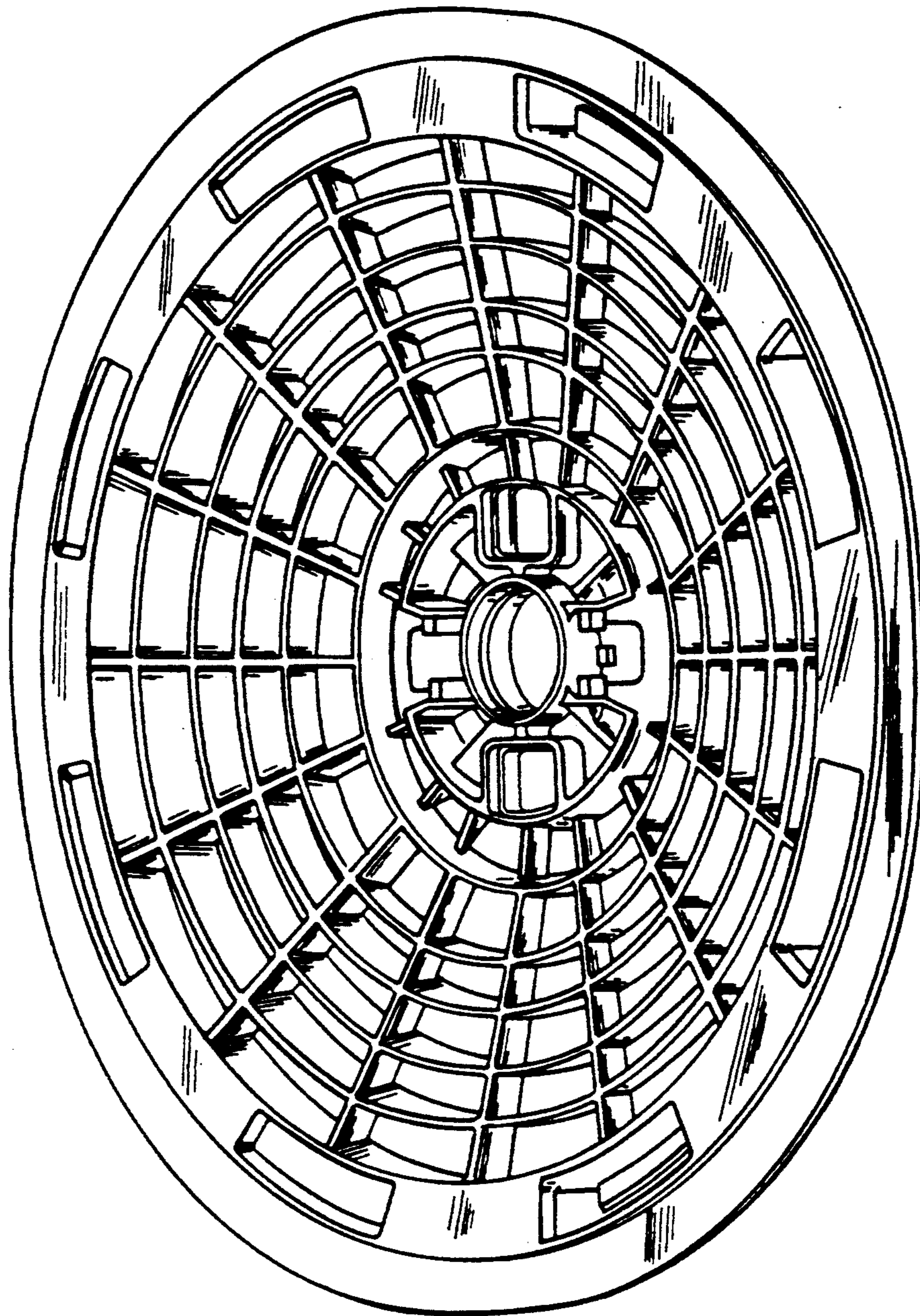

FIG. 4

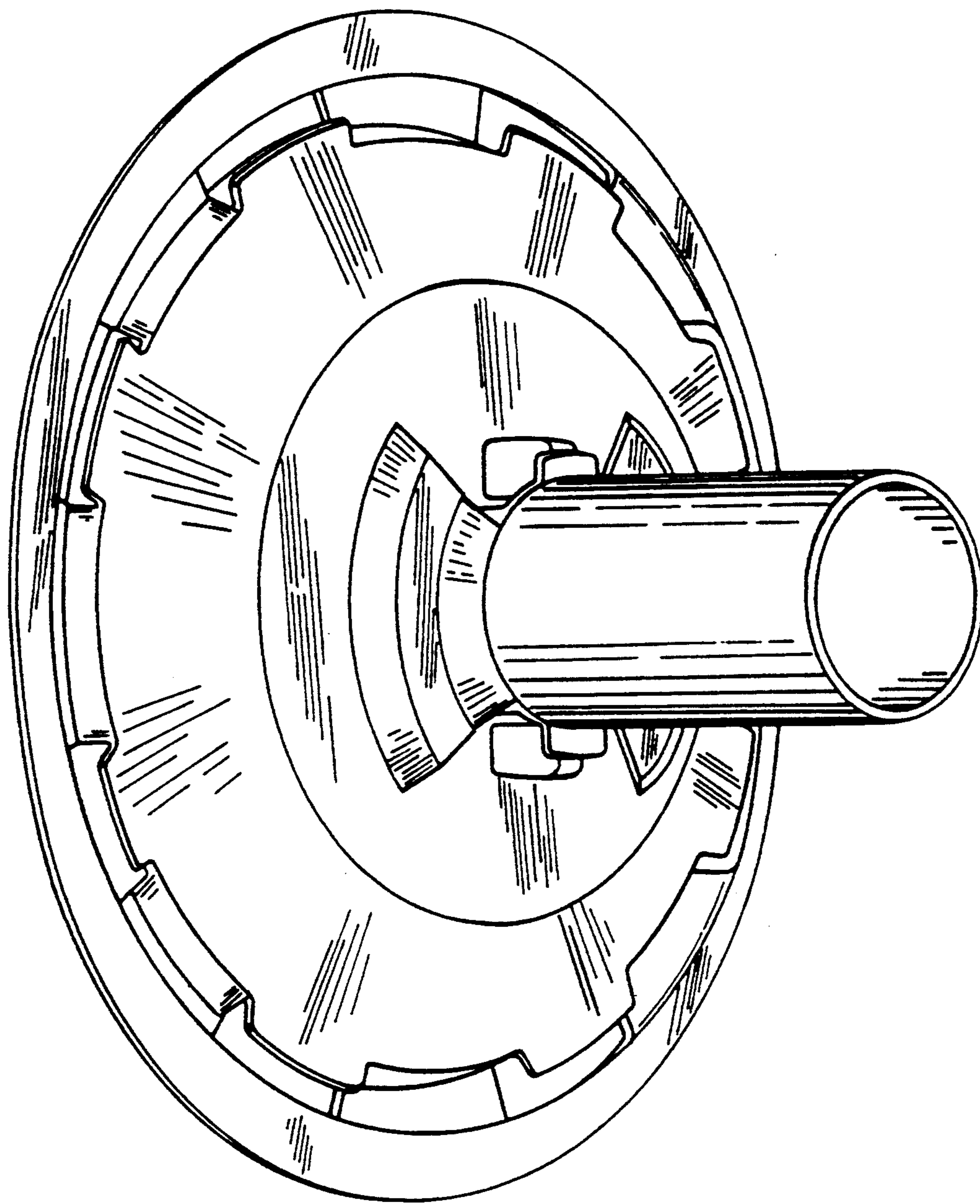

FIG. 5