



US00D346387S

# United States Patent [19]

[11] Patent Number: **Des. 346,387**

Cooper

[45] Date of Patent: **\*\* Apr. 26, 1994**

[54] **EXHAUST MANIFOLD RISER FOR MARINE ENGINES**

4,845,945 7/1989 Widmer et al. .... 60/310  
5,212,949 5/1993 Shiozawa ..... 60/310

[75] Inventor: **Thomas R. Cooper**, Bryn Athyn, Pa.

*Primary Examiner*—A. Hugo Word  
*Assistant Examiner*—R. Seifert  
*Attorney, Agent, or Firm*—Jones, Tullar & Cooper

[73] Assignee: **Oscor Motors Corporation**, Hatfield, Pa.

[57] **CLAIM**

[\*\*] Term: **14 Years**

The ornamental design for an exhaust manifold riser for marine engines, as shown and described.

[21] Appl. No.: **813,401**

[22] Filed: **Dec. 27, 1991**

**DESCRIPTION**

[52] U.S. Cl. .... **D15/4**

[58] Field of Search ..... 63/310; 44/89;  
D15/1-6

FIG. 1 is a top perspective view of an exhaust manifold riser for marine engines, showing my new design;  
FIG. 2 is a rear elevational view thereof;  
FIG. 3 is a top plan view thereof;  
FIG. 4 is a bottom plan view thereof;  
FIG. 5 is a right side elevational view thereof; and,  
FIG. 6 is a cross sectional view taken along the line 6—6 of FIG. 3.

[56] **References Cited**  
**U.S. PATENT DOCUMENTS**

4,573,318 3/1986 Entringer et al. .

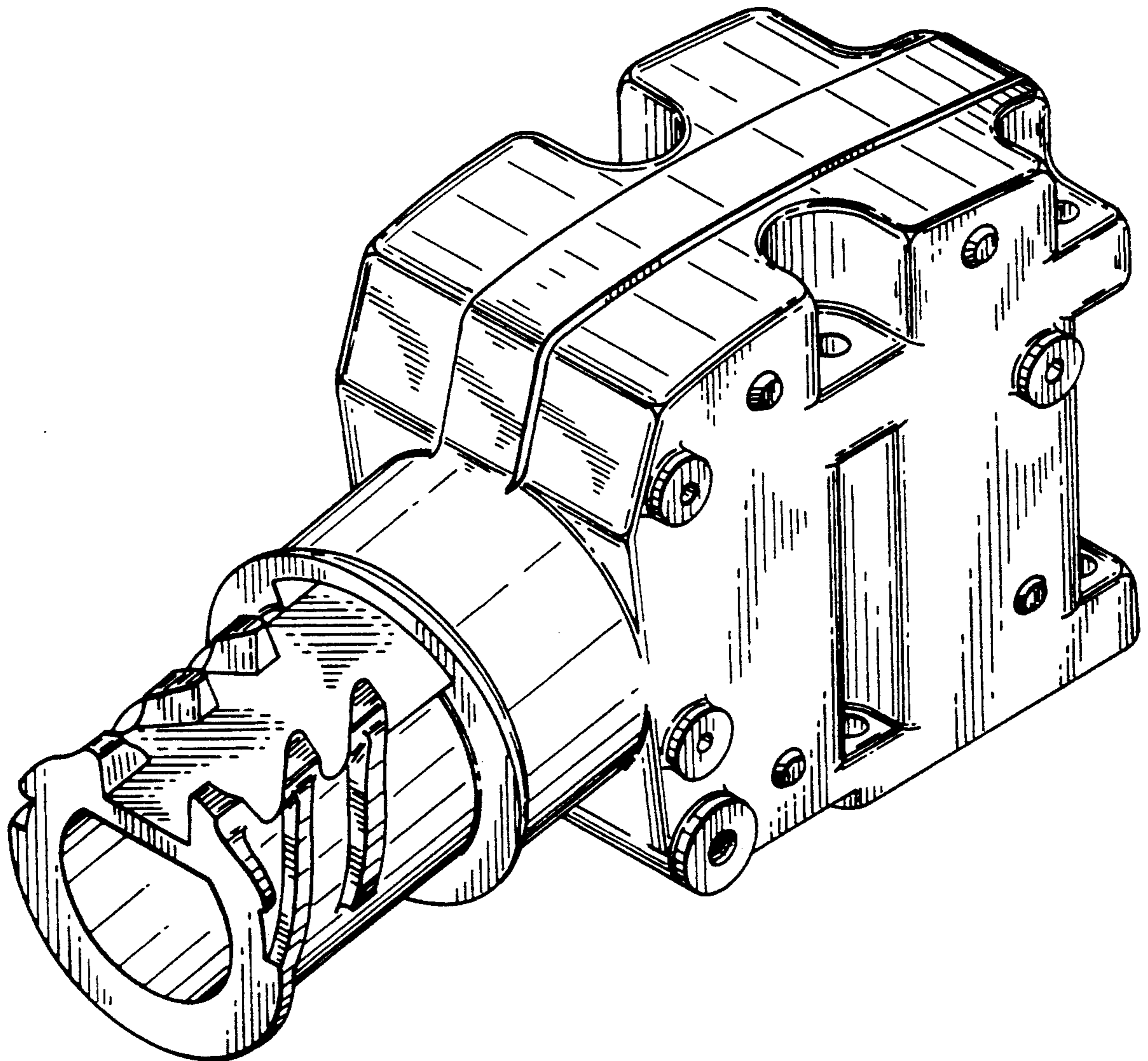

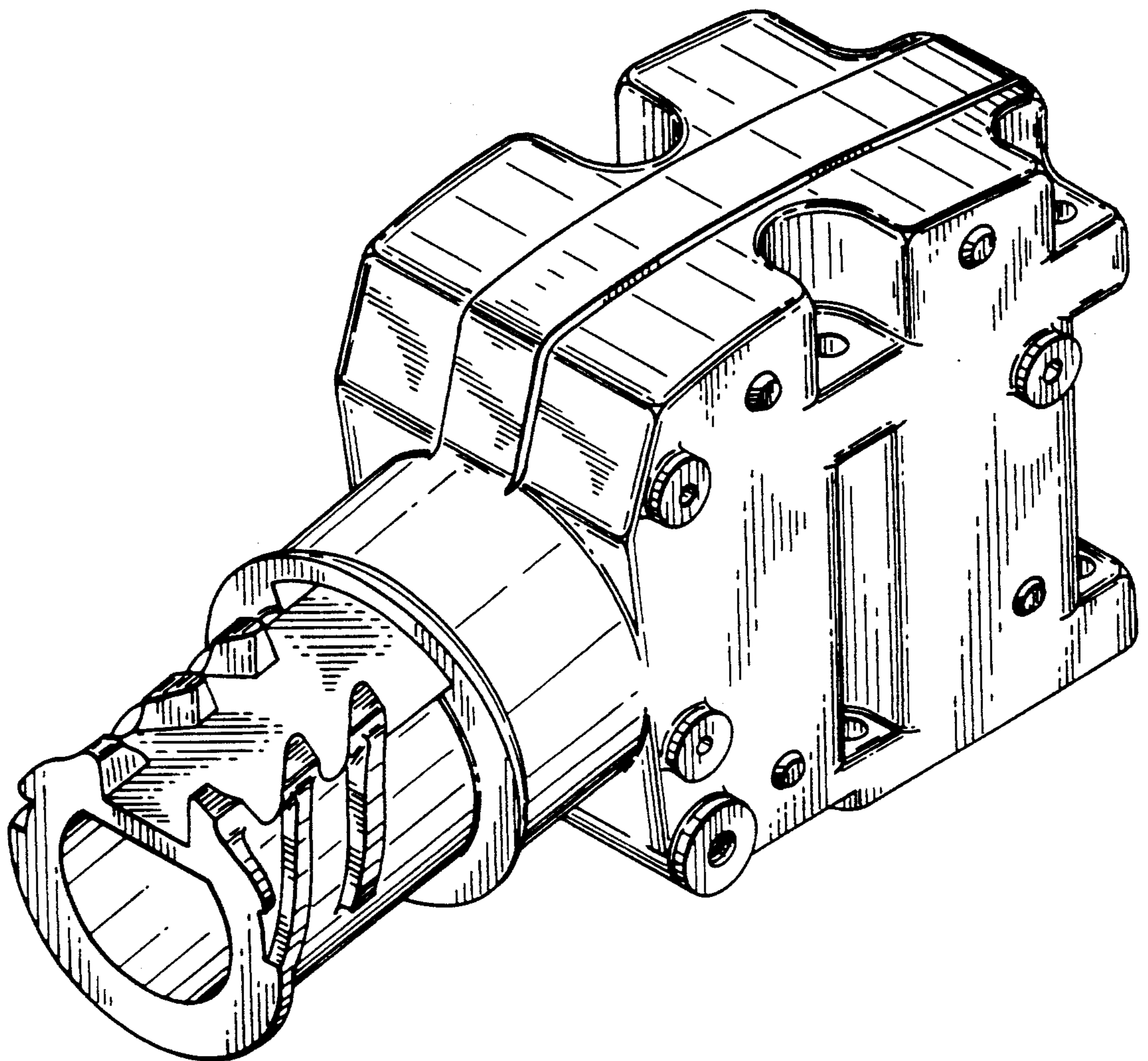

FIG. 1

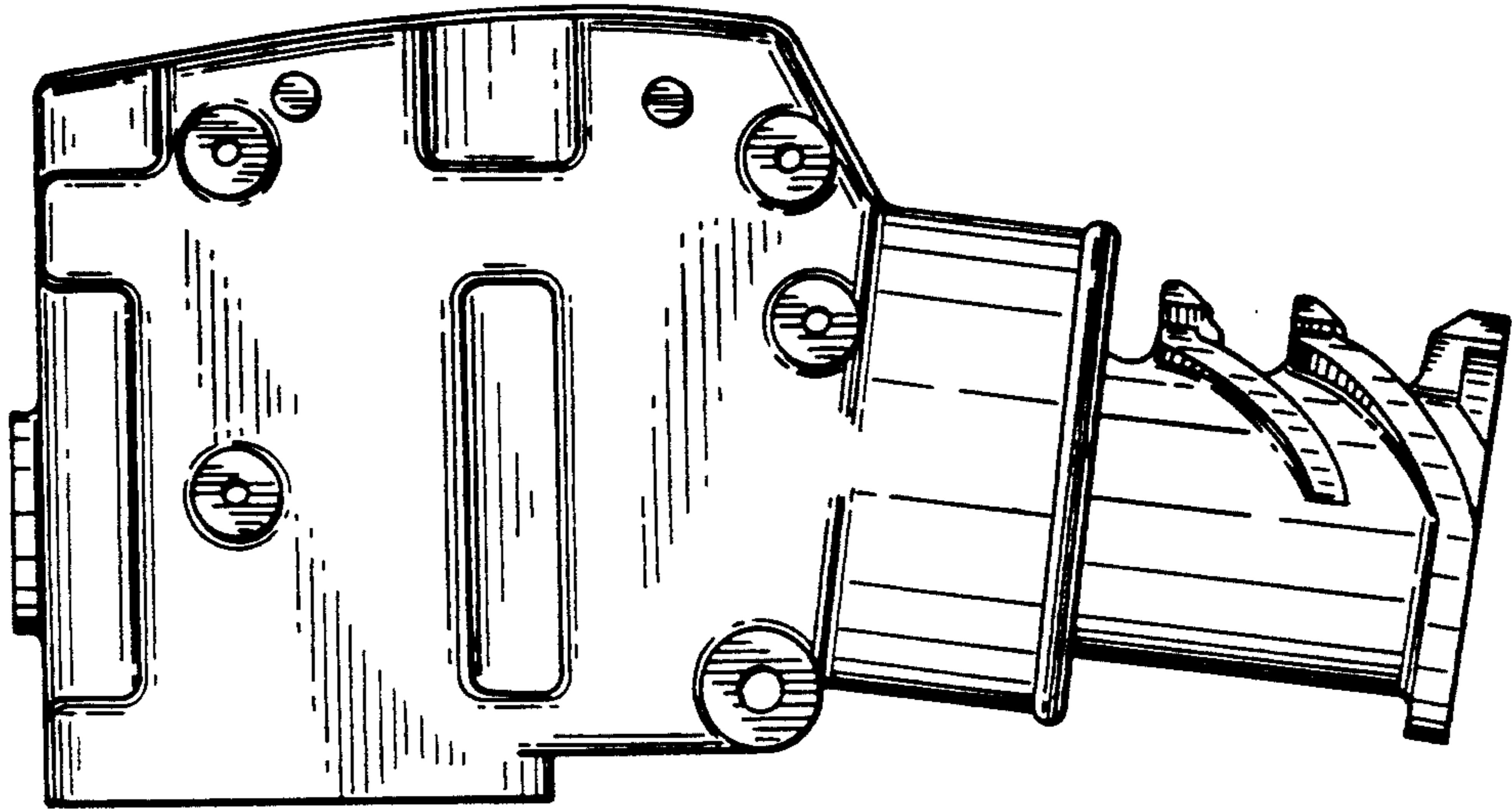

FIG. 2

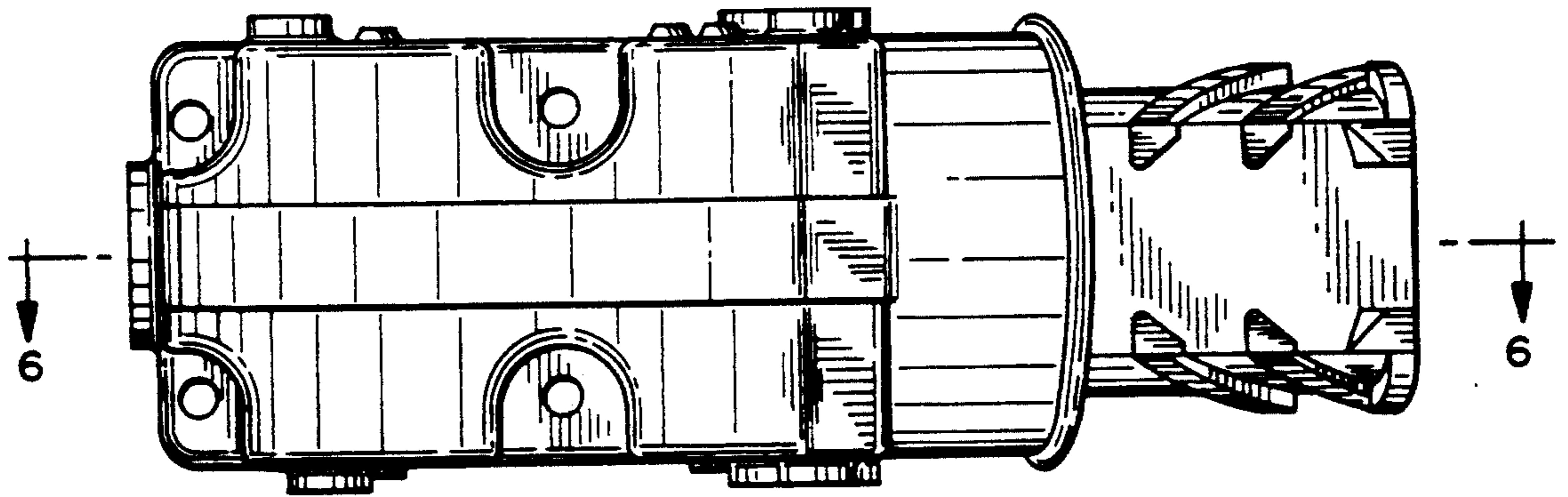

FIG. 3

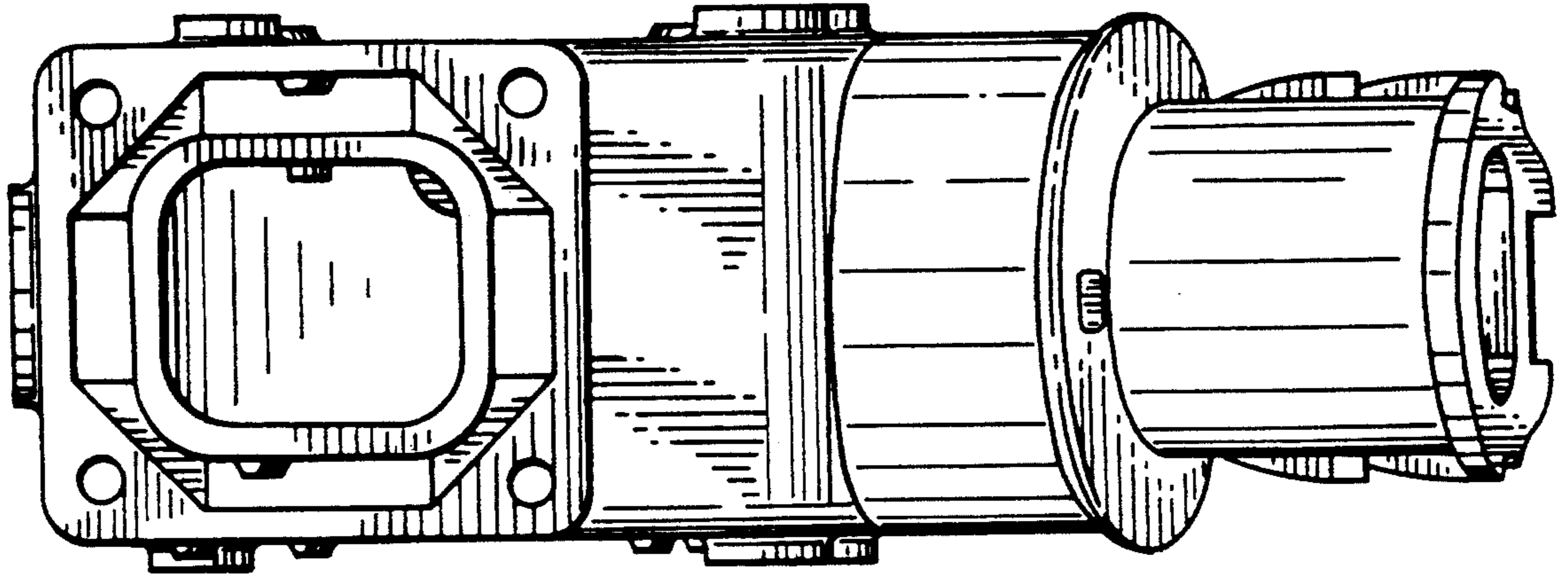

FIG. 4

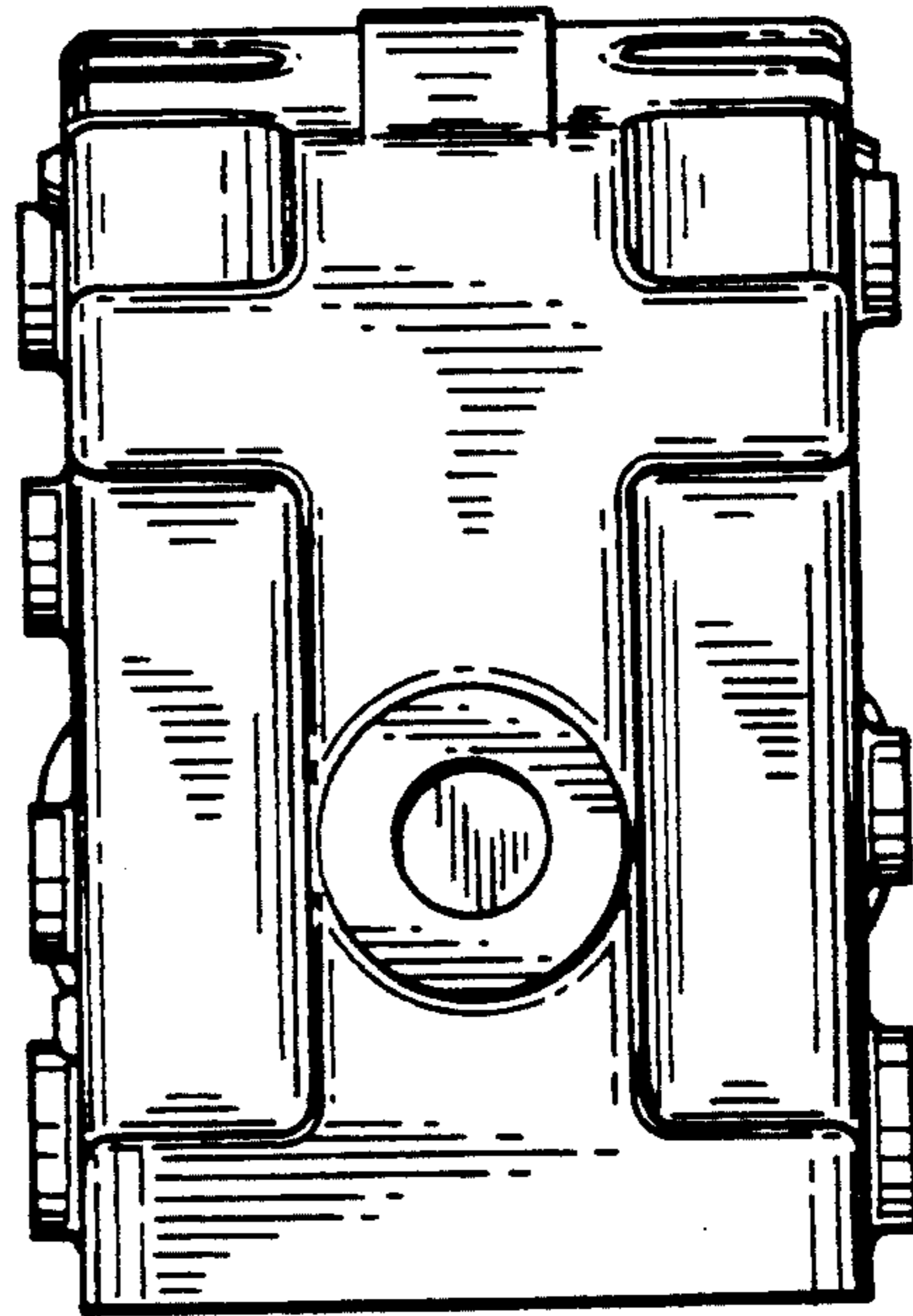

FIG. 5

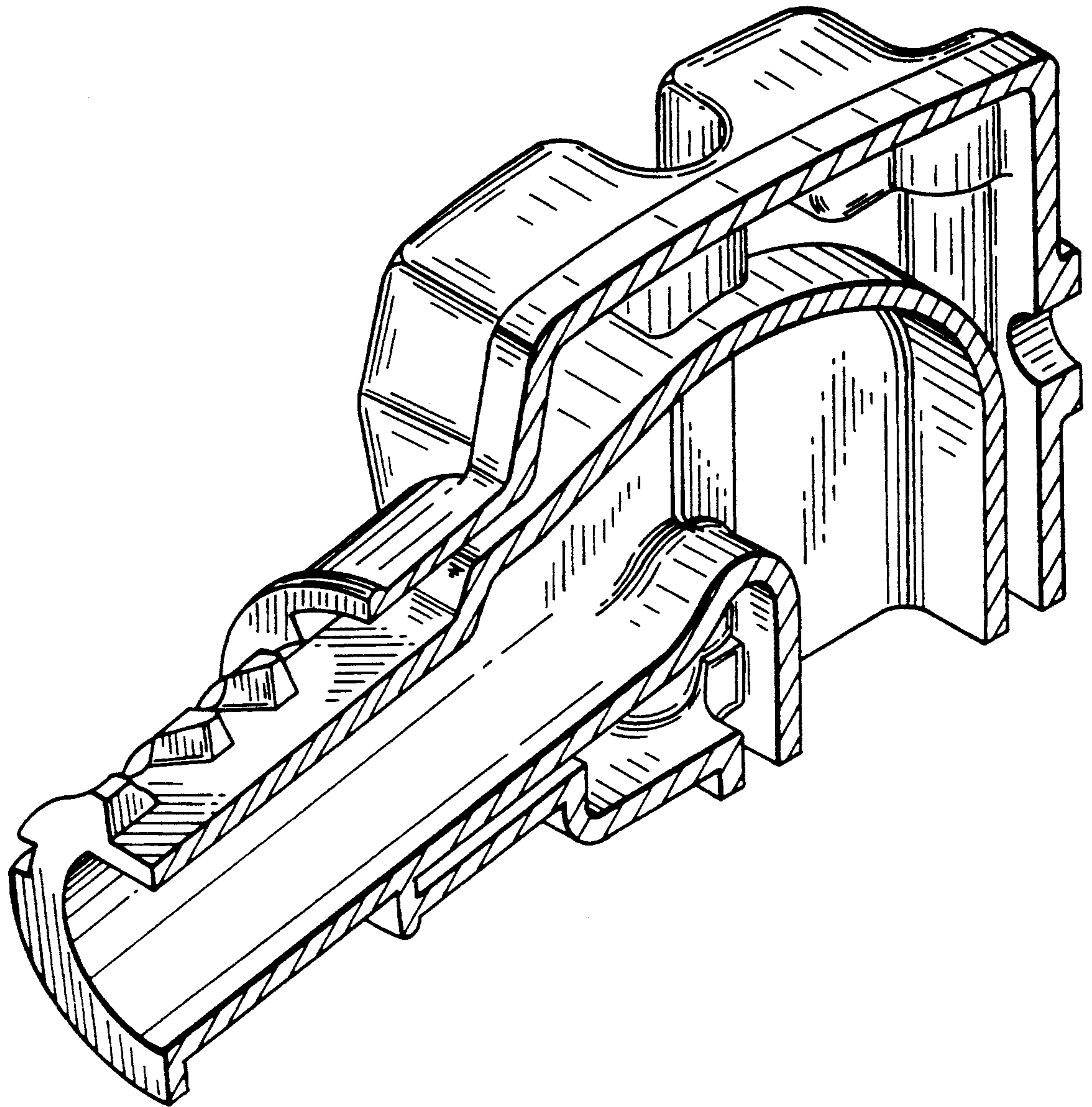

FIG. 6