



US00D346255S

United States Patent [19]

[11] Patent Number: Des. 346,255

Francis et al.

[45] Date of Patent: ** Apr. 19, 1994

[54] SWING ARM SHORT-RISE VEHICLE LIFT

[75] Inventors: Richard T. Francis, Easton; Jerry A. Ohlemeier, St. Joseph, both of Mo.

[73] Assignee: Gray Automotive Products Company, St. Joseph, Mo.

[**] Term: 14 Years

[21] Appl. No.: 8,684

[22] Filed: May 21, 1993

[52] U.S. Cl. D34/31; D34/28

[58] Field of Search 254/122, 89 H, 89 R, 254/1 R, 8.43, 90; D34/38

[56] References Cited

U.S. PATENT DOCUMENTS

D. 239,707	4/1976	Girimaldo	D34/34
D. 273,433	4/1984	Masui	D34/28
4,447,042	5/1984	Masui	254/122
4,848,732	7/1989	Rossato	254/89 H

Primary Examiner—Kay H. Chin

Attorney, Agent, or Firm—Hovey, Williams, Timmons & Collins

[57] CLAIM

The ornamental design for a swing arm short-rise vehicle lift, as shown and described.

DESCRIPTION

FIG. 1 is a perspective view of a swing arm short-rise vehicle lift showing a first preferred embodiment of my new design;

FIG. 2 is a right side elevational view thereof;

FIG. 3 is a top plan view thereof;

FIG. 4 is a right side elevational view thereof;

FIG. 5 is a rear elevational view thereof;

FIG. 6 is a front elevational view thereof;

FIG. 7 is a top plan view of a swing arm short-rise vehicle lift showing a second preferred embodiment of my new design, wherein the swing arms are removed from the short-rise vehicle lift; and,

FIG. 8 is a rear elevational view thereof.

The broken line showing of a vehicle in FIG. 2 is for illustrative purposes only and does not form a part of the claimed design.

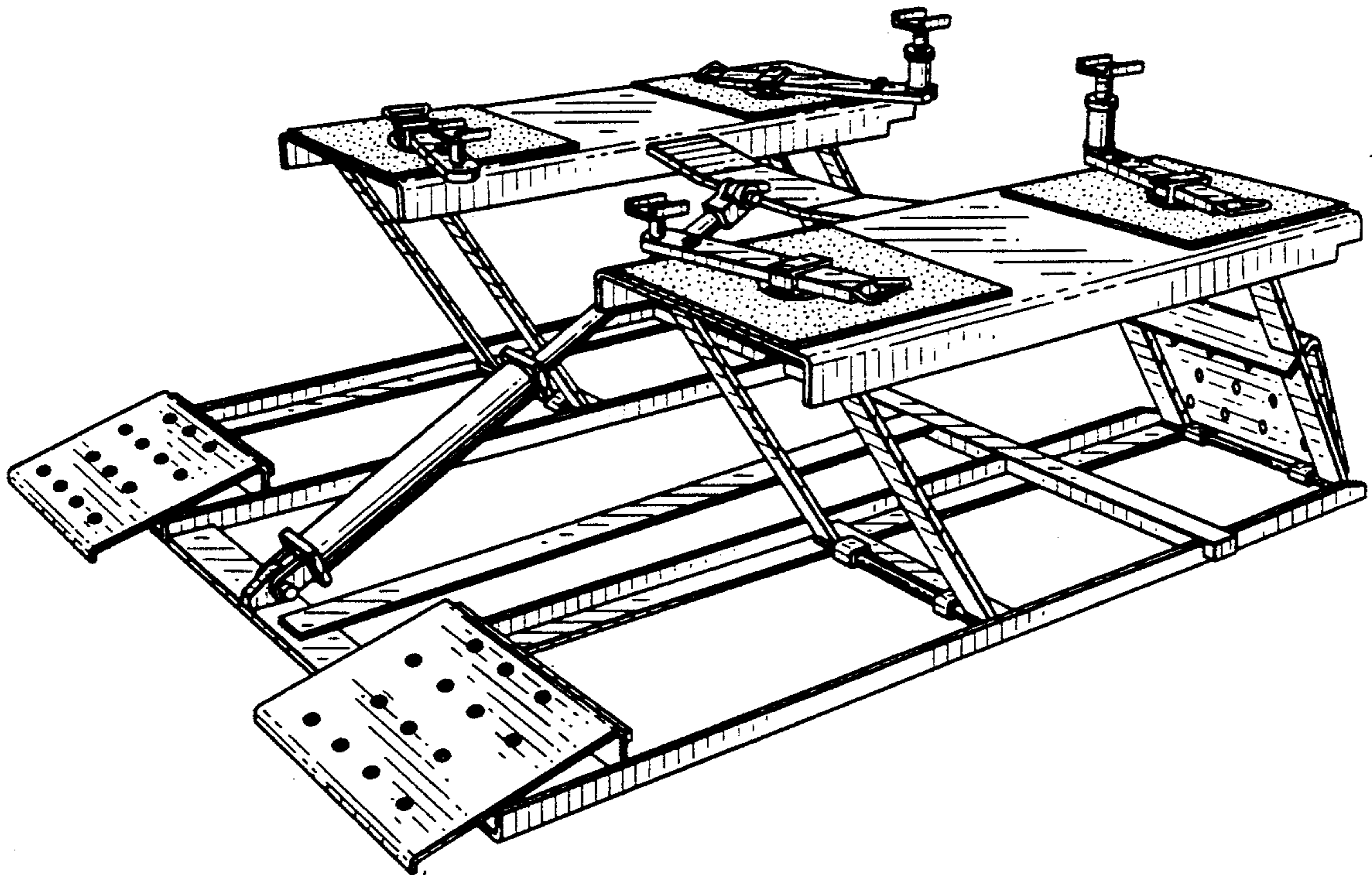

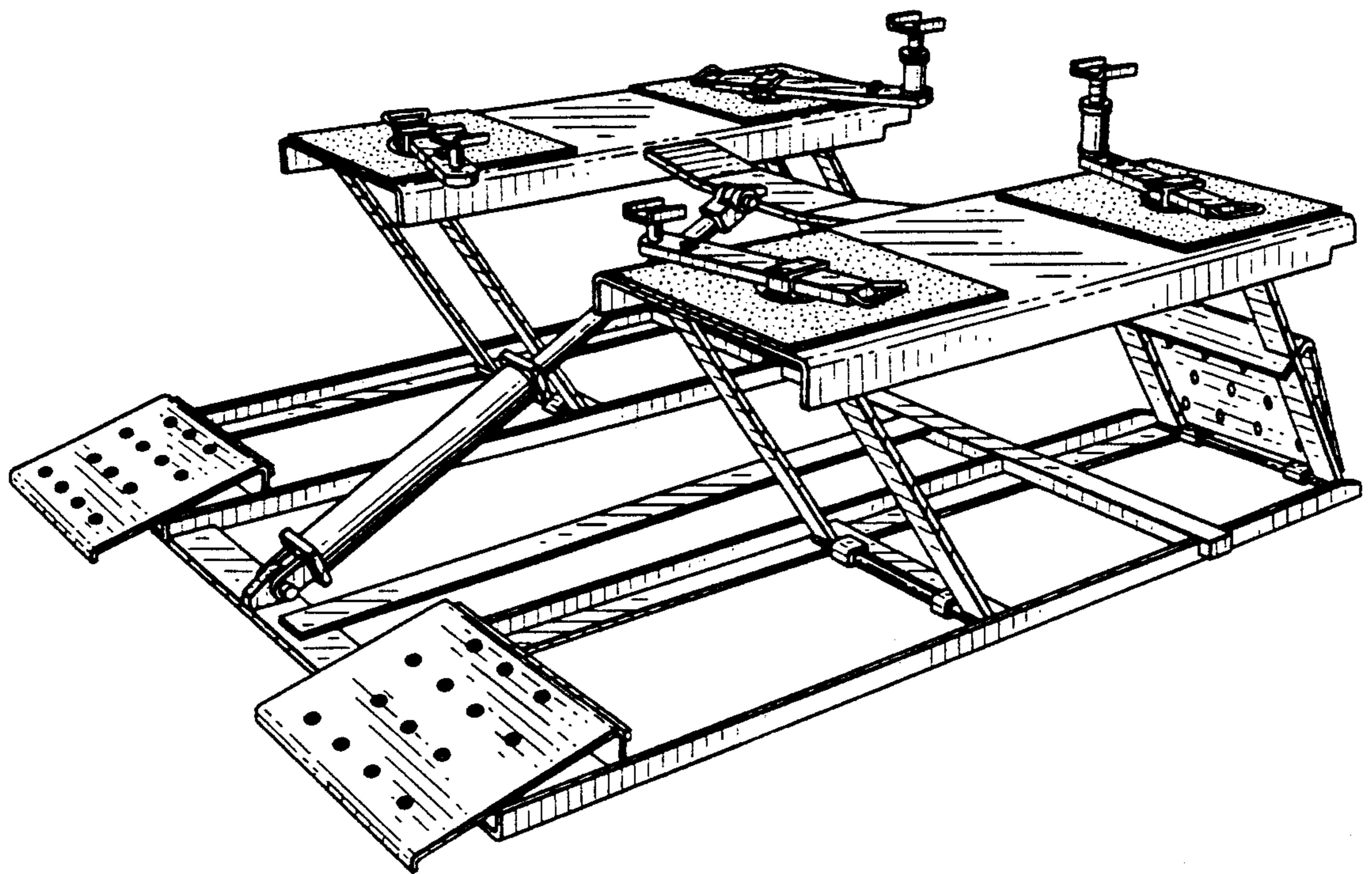

FIG. 1.

FIG. 2.

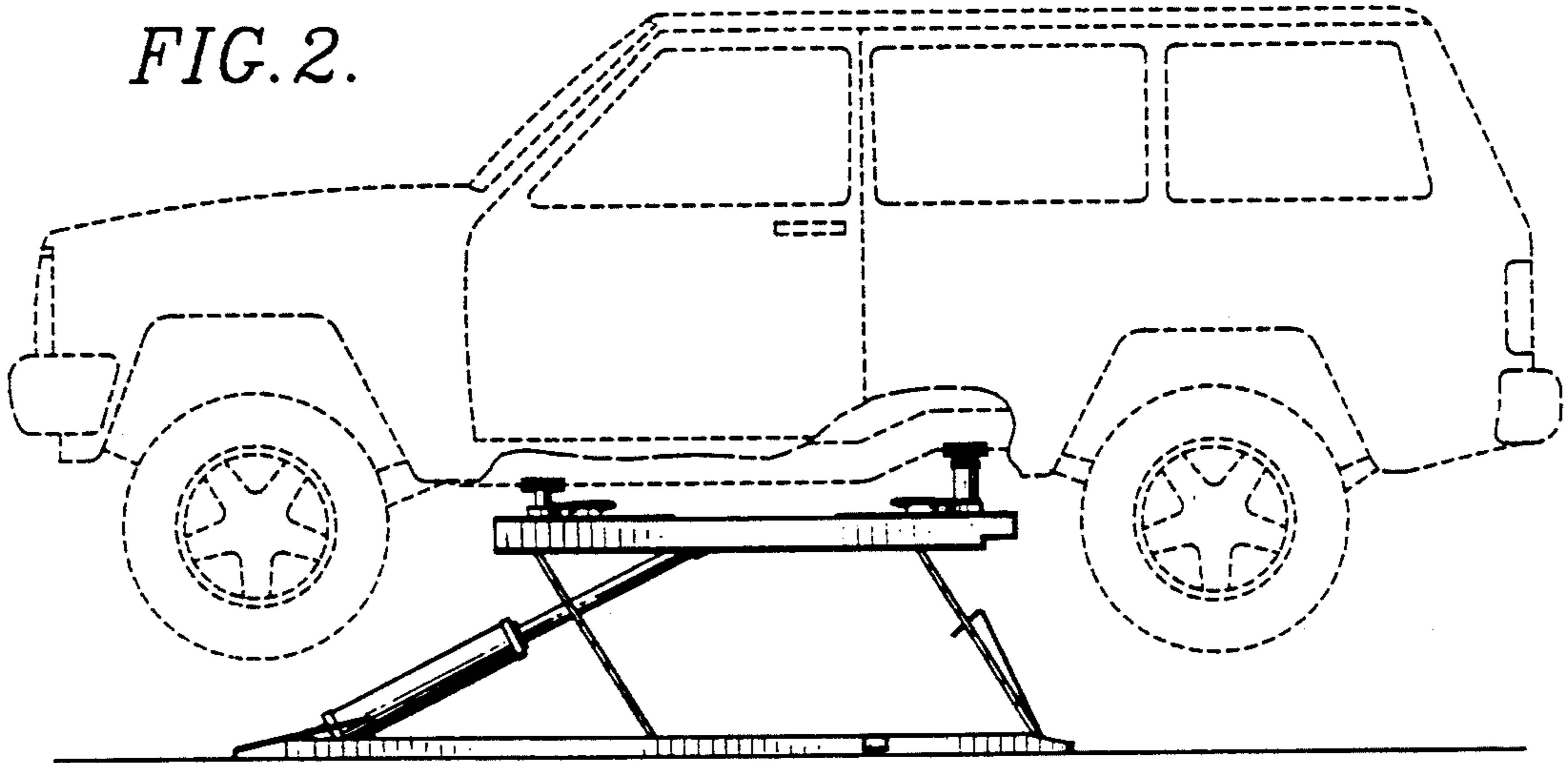

FIG. 3.

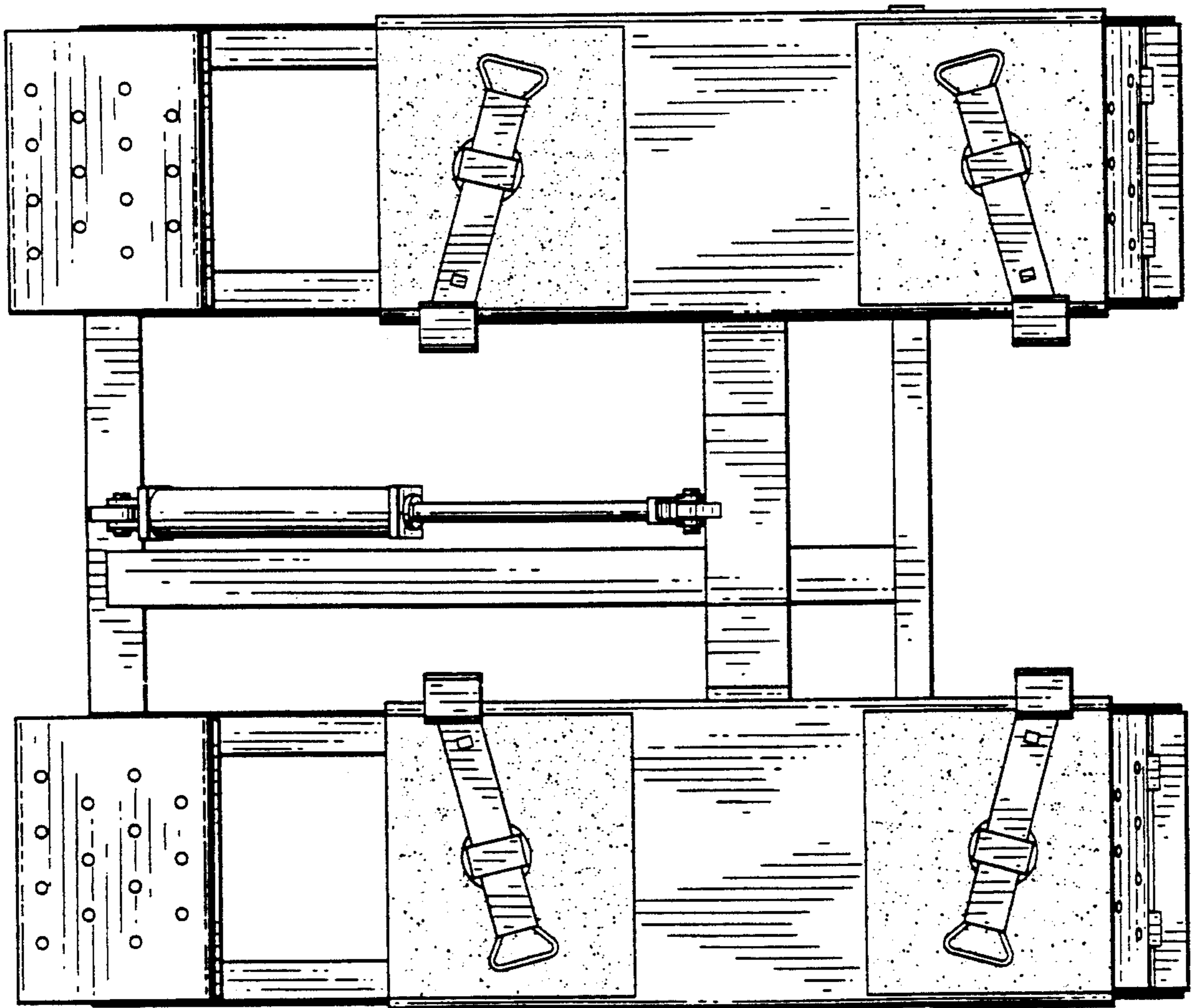

FIG. 5.

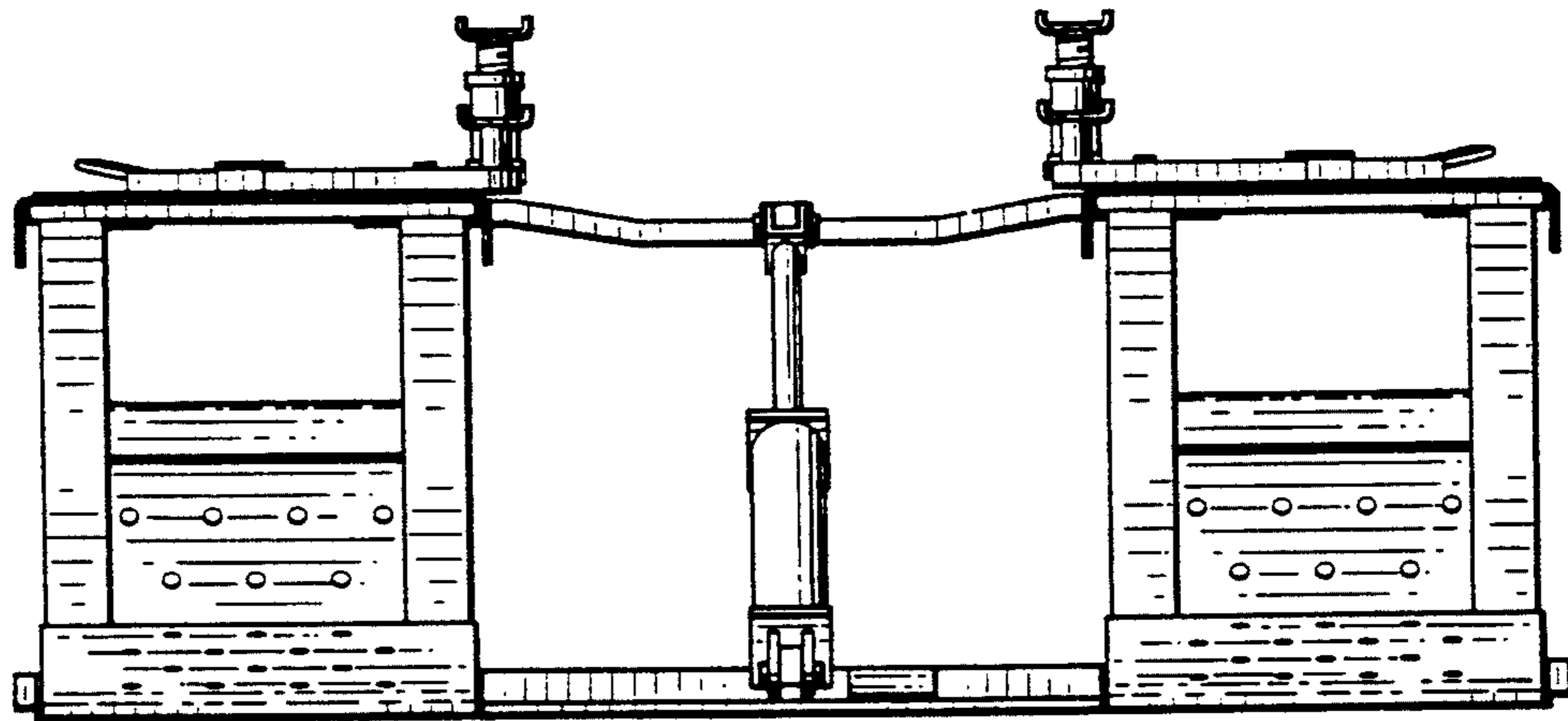
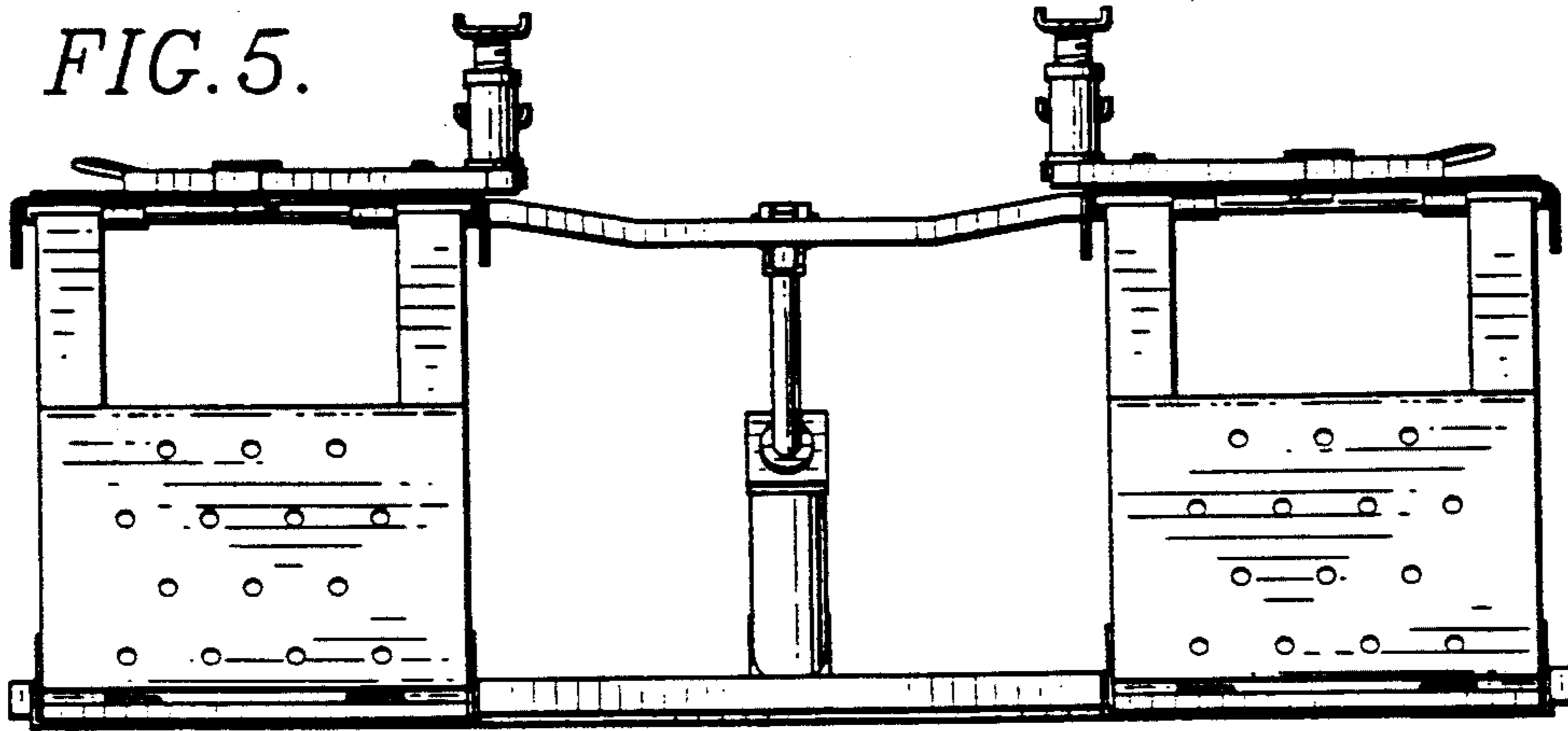
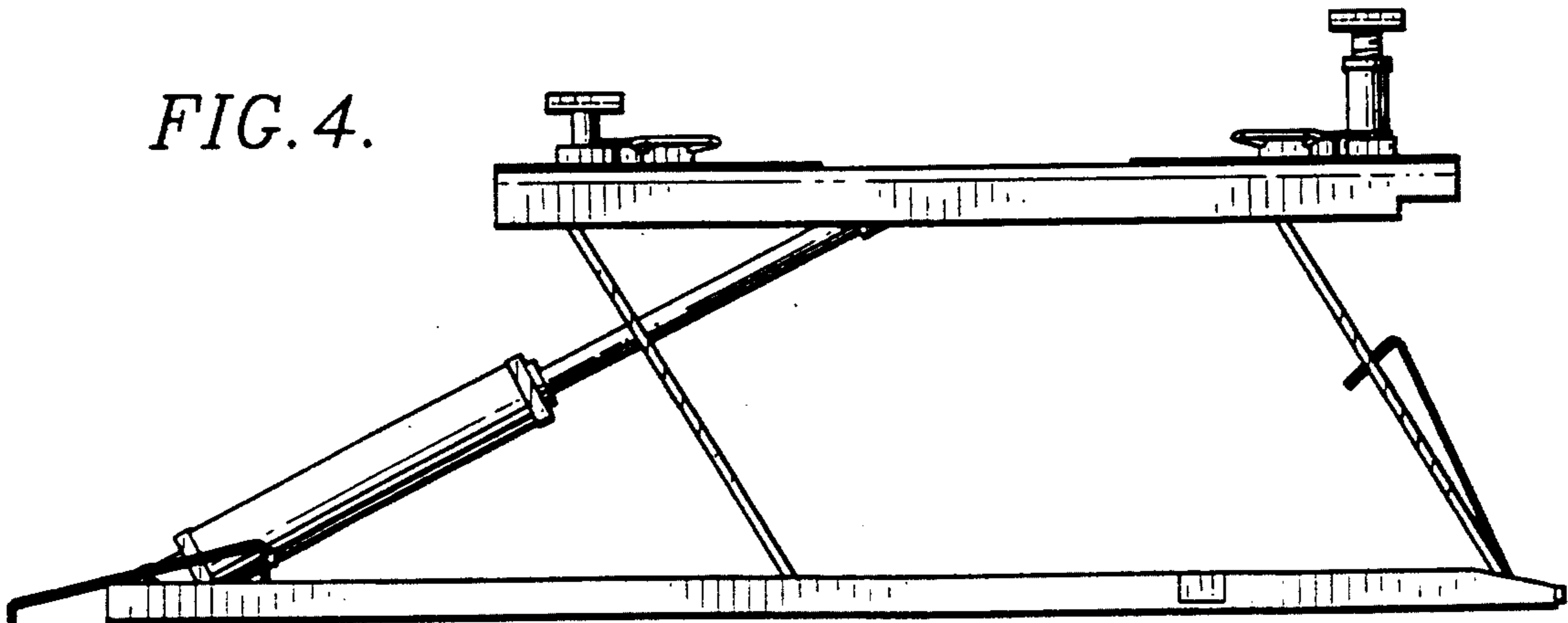

FIG. 6.

FIG. 4.



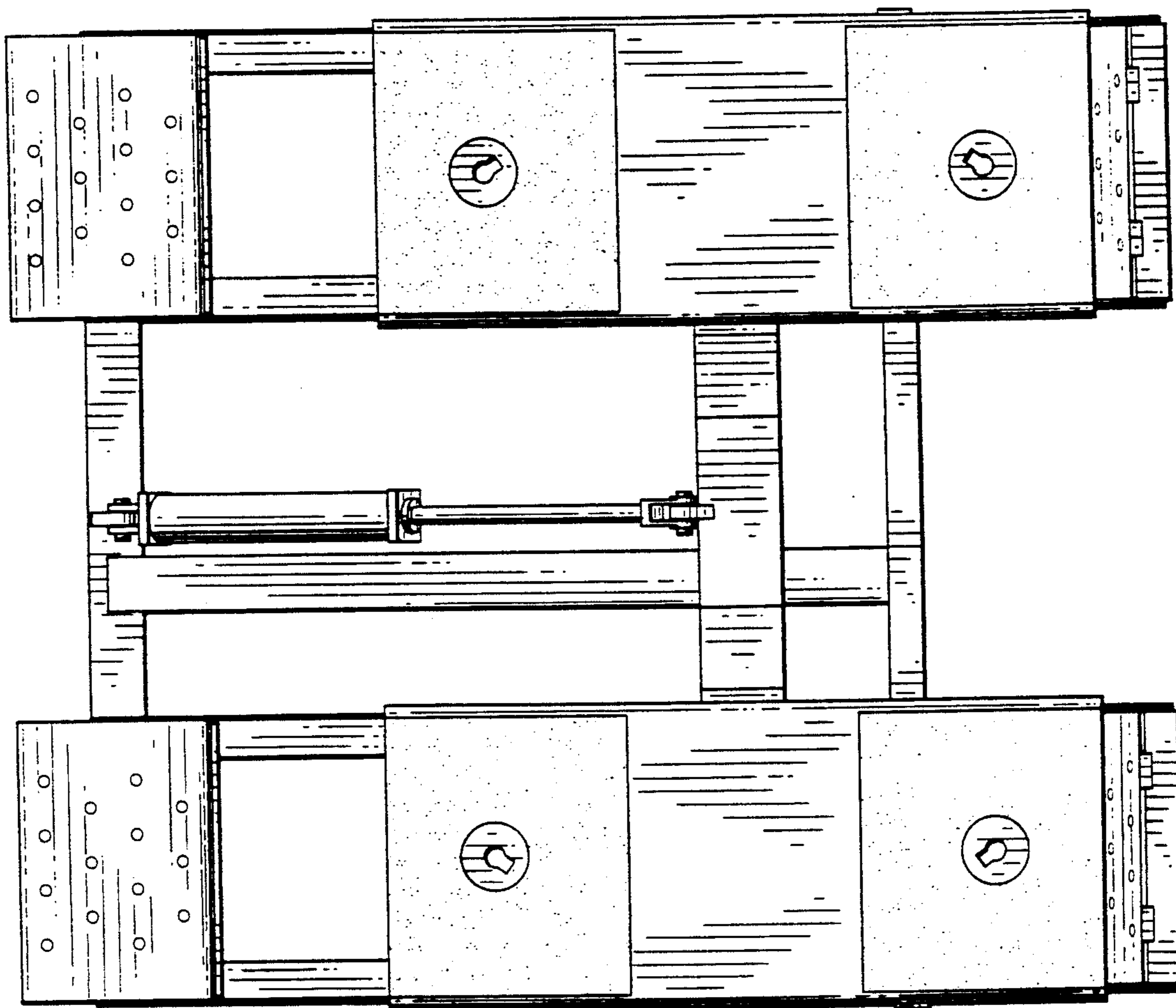

FIG. 7.

FIG. 8.

