



US00D346234S

United States Patent [19]

[11] Patent Number: **Des. 346,234**

Sammis

[45] Date of Patent: **** Apr. 19, 1994**

[54] **ADJUSTABLE, MAGNETICALLY MOUNTED WARNING LIGHT FOR A VEHICLE**

3,936,670 2/1976 Allen, Sr. 362/397 X
4,075,470 2/1978 Moore 362/287
4,229,781 10/1980 Hitora 362/274

[76] Inventor: **James A. Sammis, 5562 Poplar Pl., Buford, Hall County, Ga. 30518**

OTHER PUBLICATIONS

Kilborn-Sauer Co. Marine Specialties Catalog, 1939, p. 5, Searchlight #1503.

[**] Term: **14 Years**

Primary Examiner—Susan J. Lucas

[21] Appl. No.: **817,674**

Attorney, Agent, or Firm—Deveau, Colton & Marquis

[22] Filed: **Jan. 7, 1992**

[52] U.S. Cl. **D26/29; D26/60; D26/63**

[57] CLAIM

[58] Field of Search **462/67, 80, 80.1, 83, 462/83.3, 269, 275, 287, 418, 419, 427, 397, 398; D26/28-36, 63, 60**

The ornamental design for a adjustable, magnetically mounted warning light for a vehicle, as shown and described.

DESCRIPTION

[56] References Cited

U.S. PATENT DOCUMENTS

D. 74,786	3/1928	Edelmann	D26/29
D: 269,296	6/1983	Stanuch et al.	D26/63
1,433,504	10/1922	Grigsby	362/419 X
1,933,965	11/1933	Carlson	240/52.2
2,484,142	10/1949	Arnold	177/329
2,675,534	4/1954	Bryant	340/97
2,675,545	4/1954	Wolper	340/366
2,812,423	11/1957	Penna	240/8.18
2,905,925	9/1959	Whiteneck	340/82
2,938,110	5/1960	Busch et al.	240/8.18

FIG. 1 is a perspective view of a adjustable, magnetically mounted warning light for a vehicle showing the new, original and ornamental design;
FIG. 2 is a front elevation view thereof;
FIG. 3 is a left-side elevation view thereof;
FIG. 4 is a rear elevation view thereof;
FIG. 5 is a righthand side elevation view thereof;
FIG. 6 is a bottom plan view thereof;
FIG. 7 is a top plan view thereof; and,
FIG. 8 is a perspective view thereof on a reduced scale, the fragmentary vehicle and second light being shown in broken lines for illustrative purposes only.

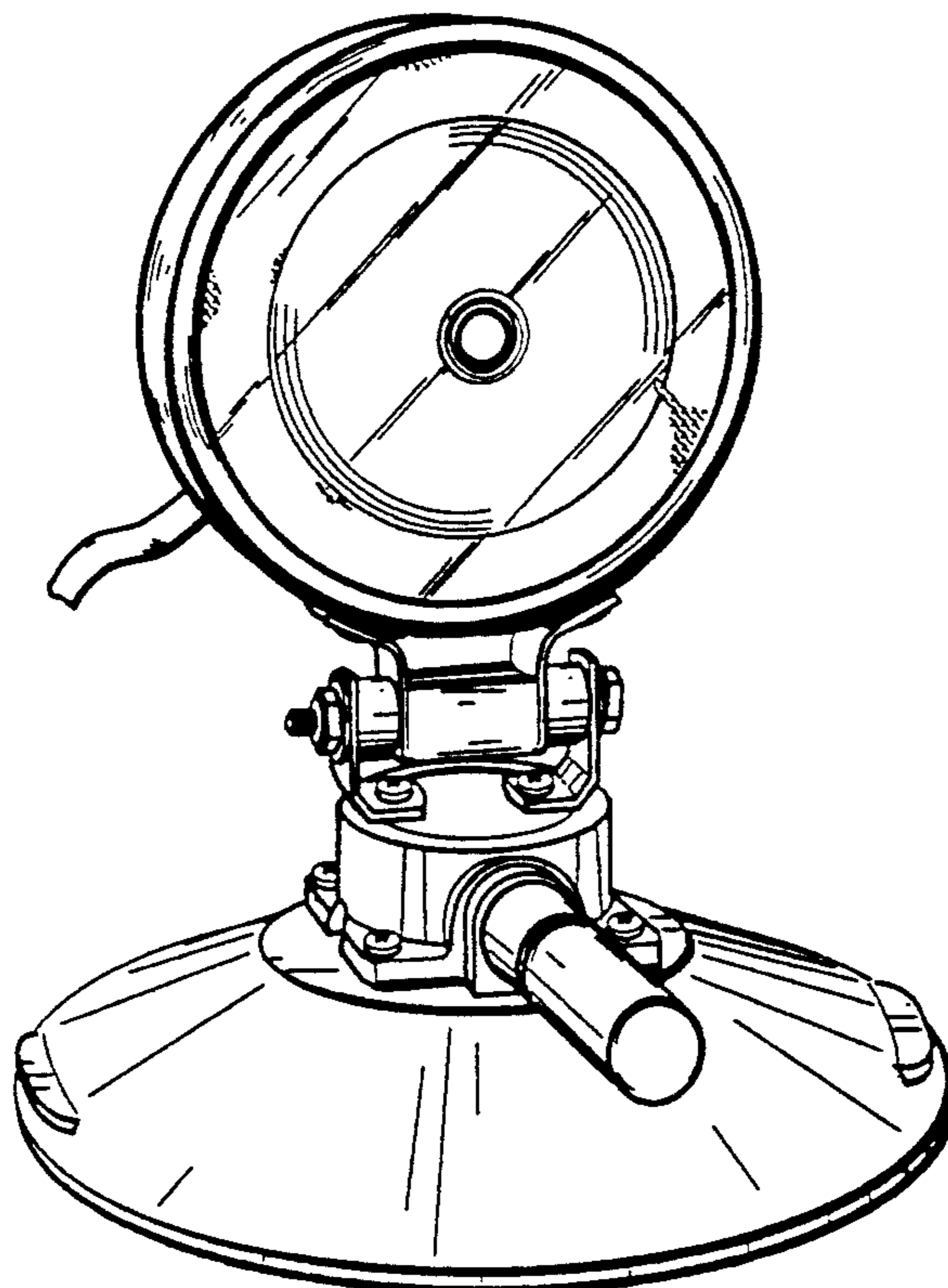

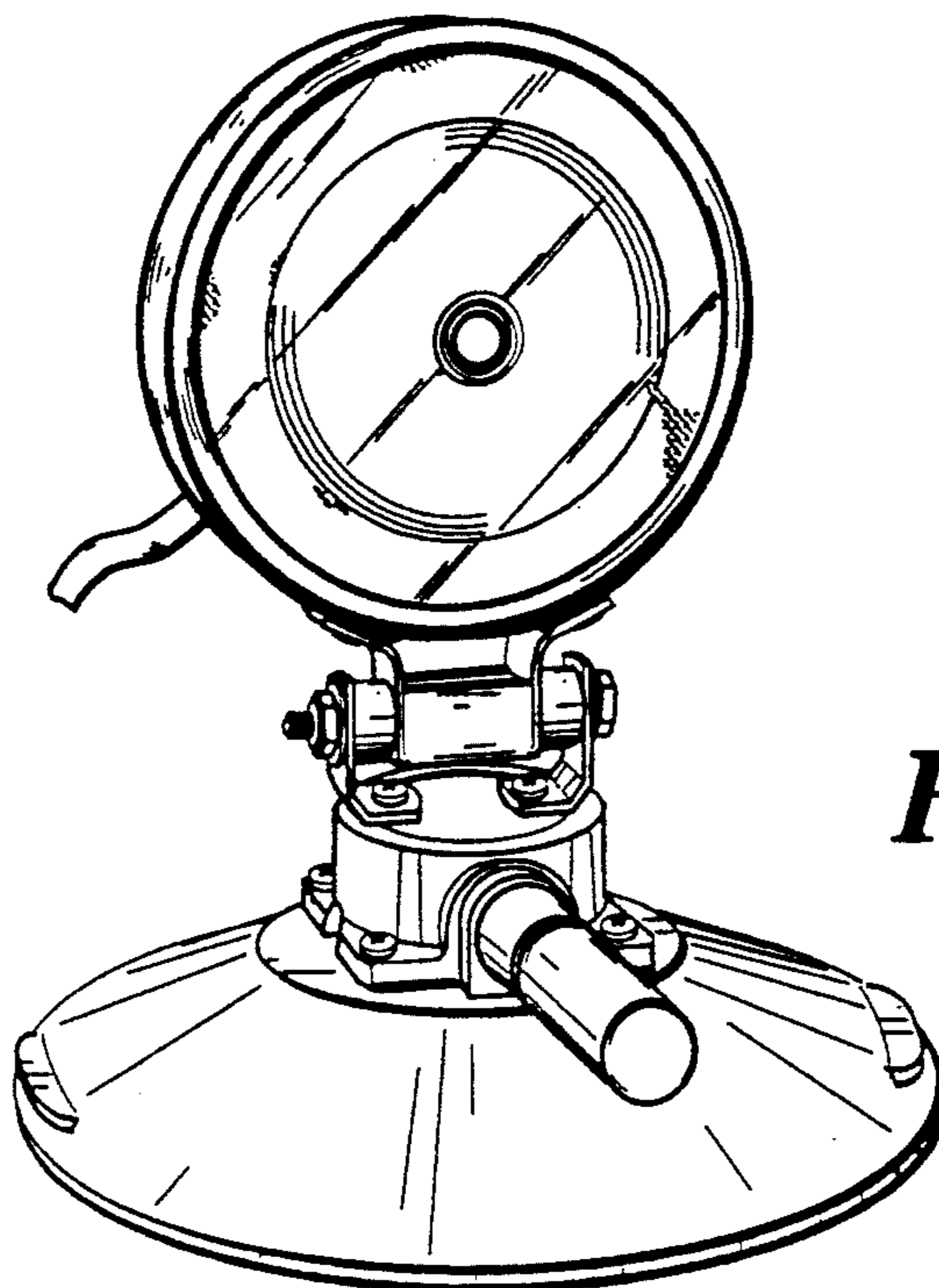

FIG 1

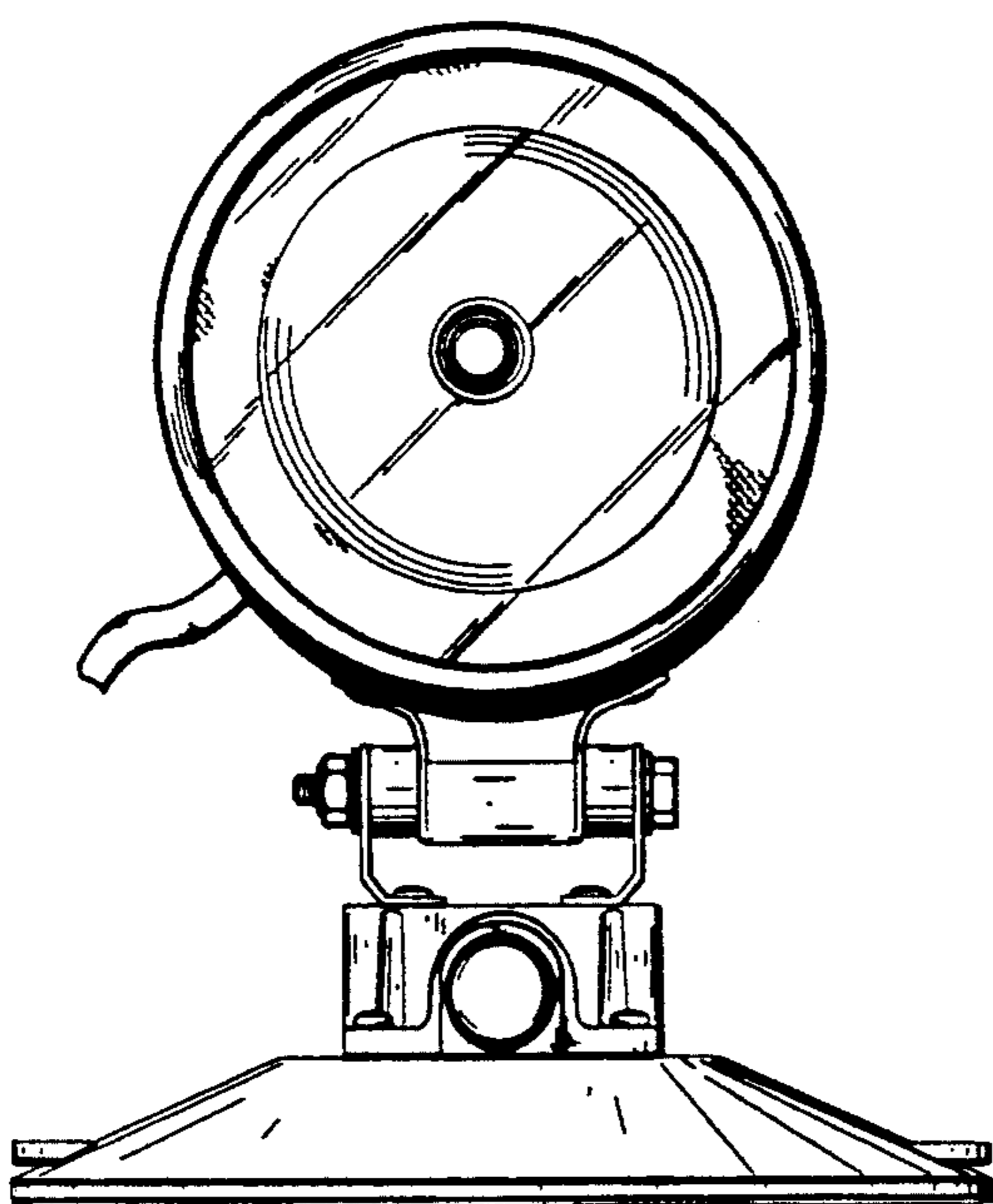

FIG 2

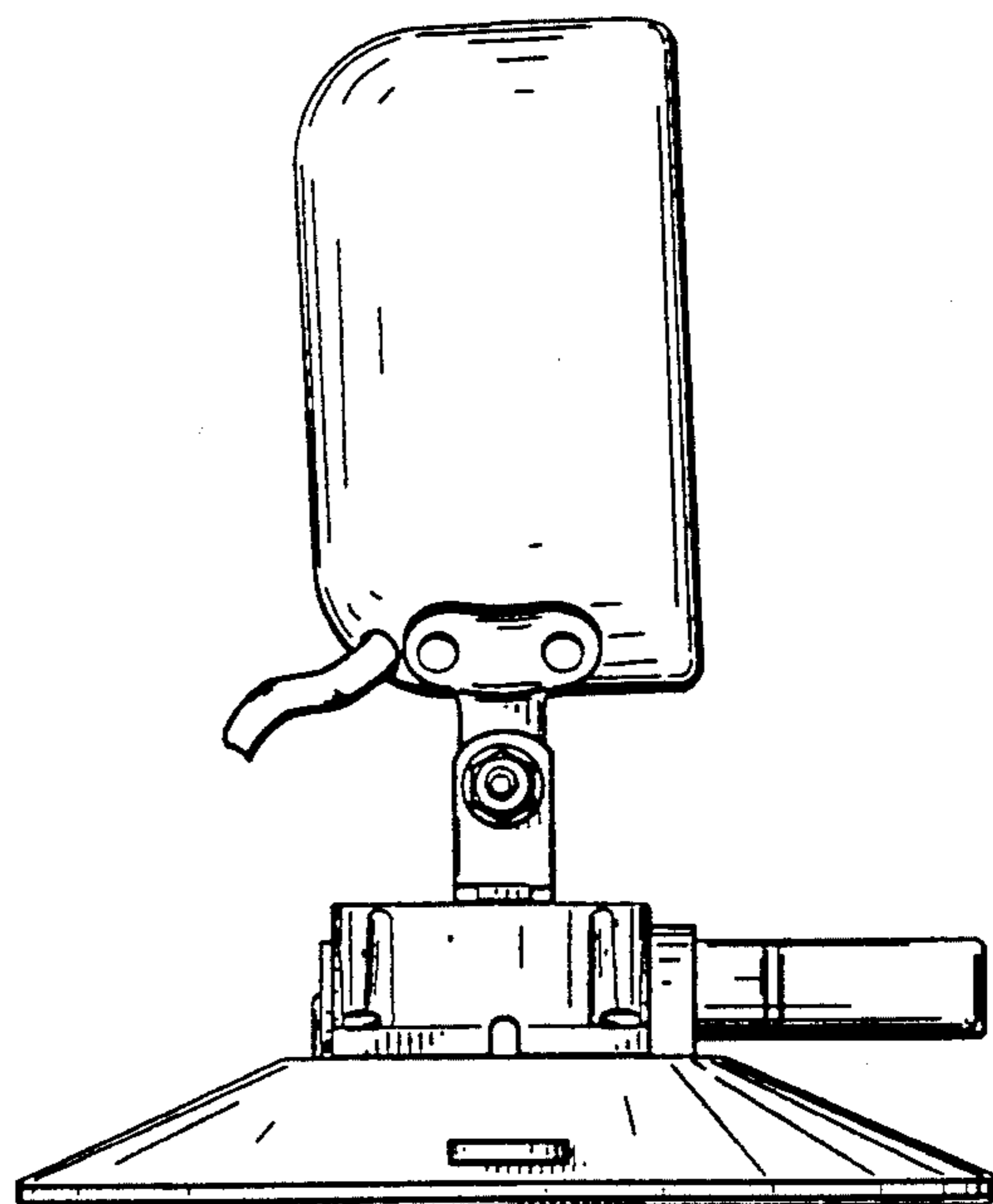

FIG 3

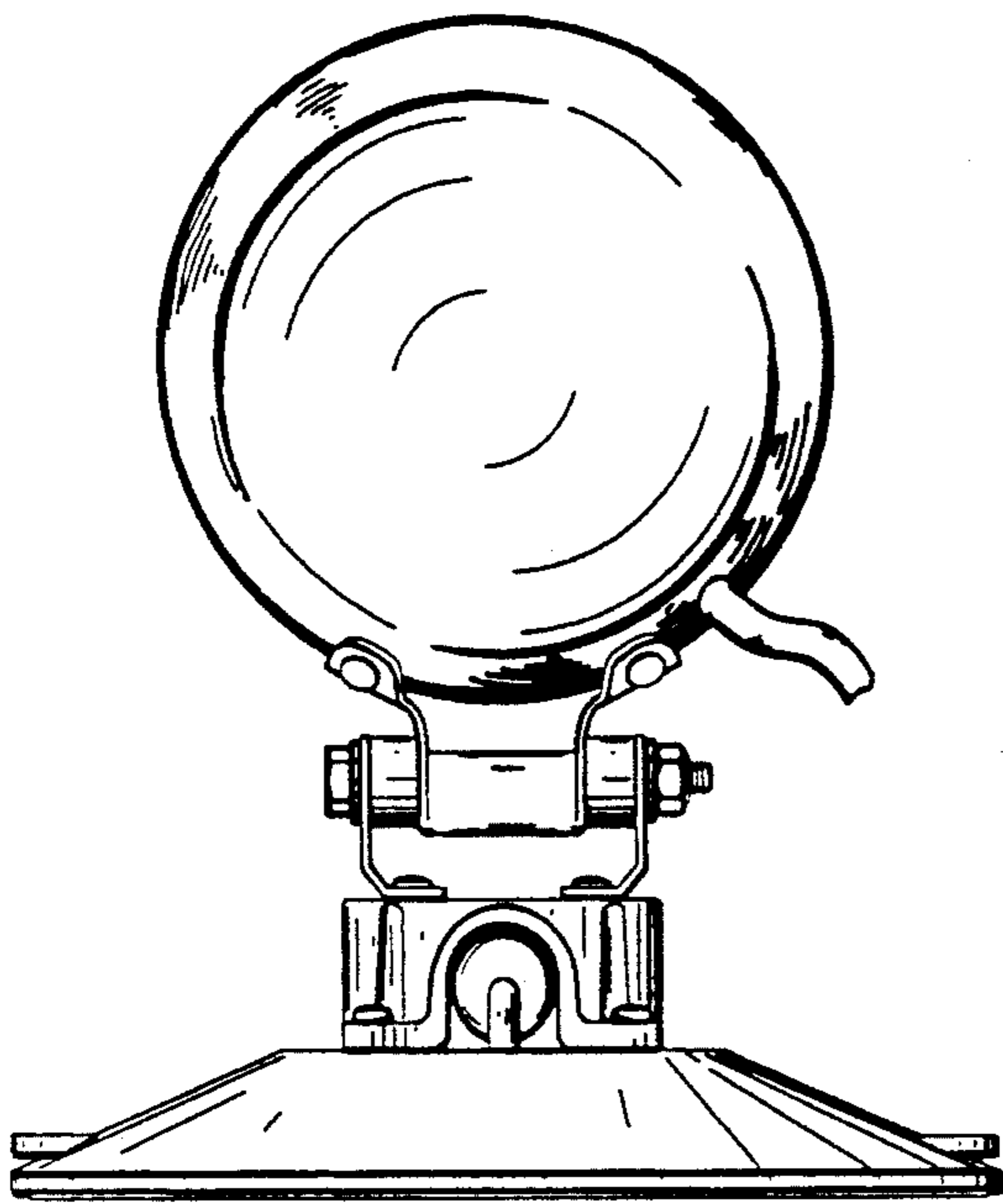

FIG 4

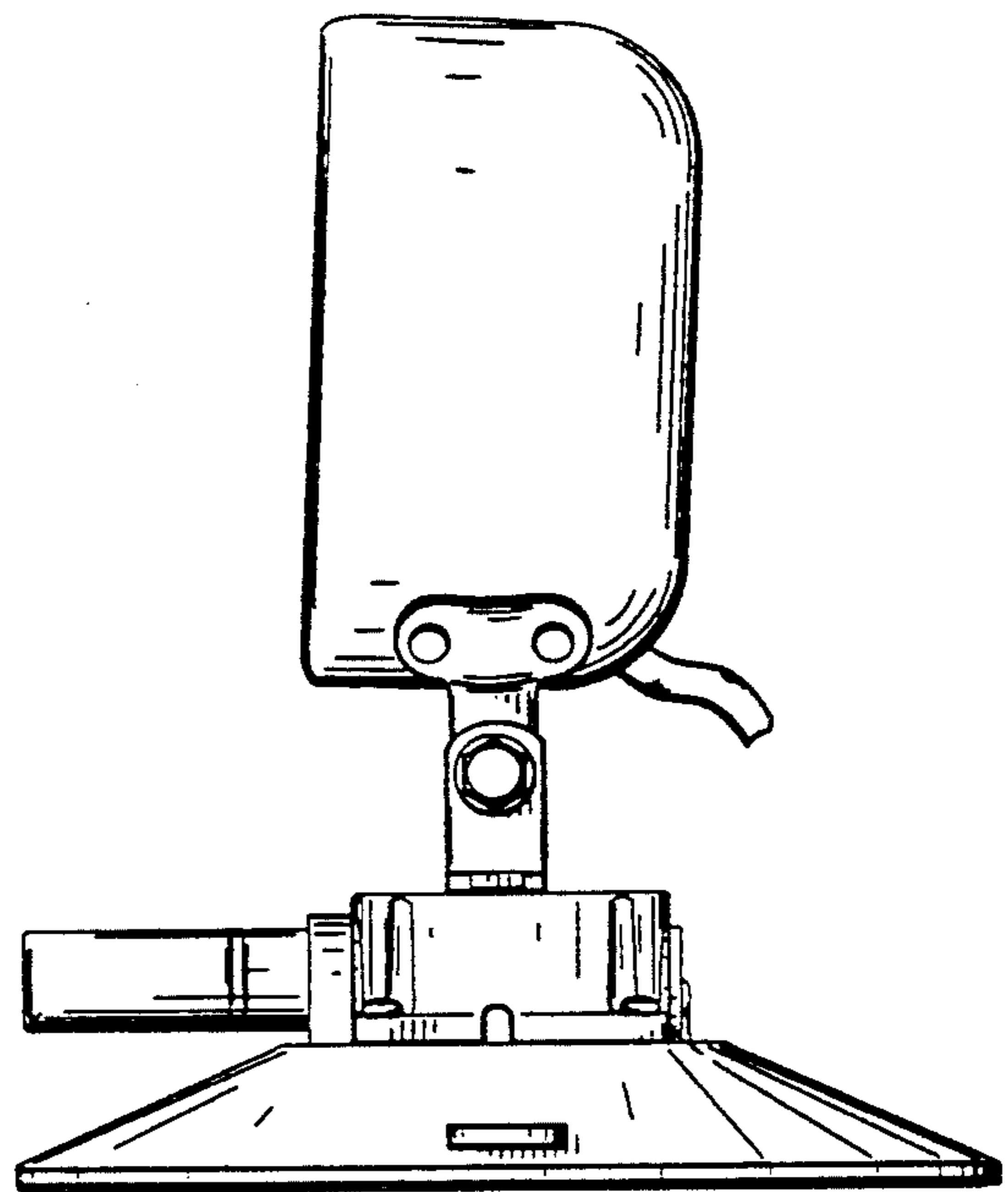

FIG 5

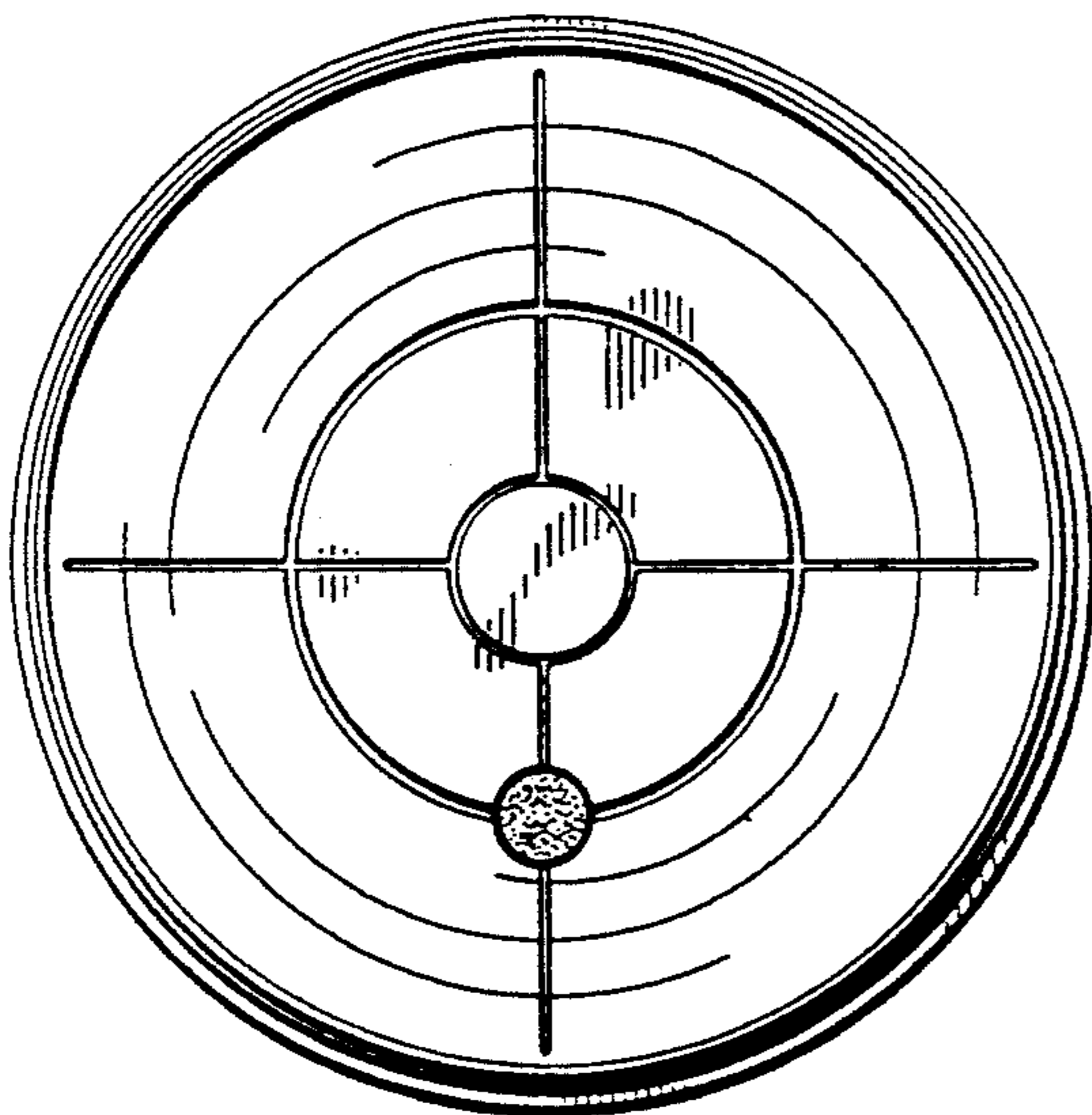

FIG 6

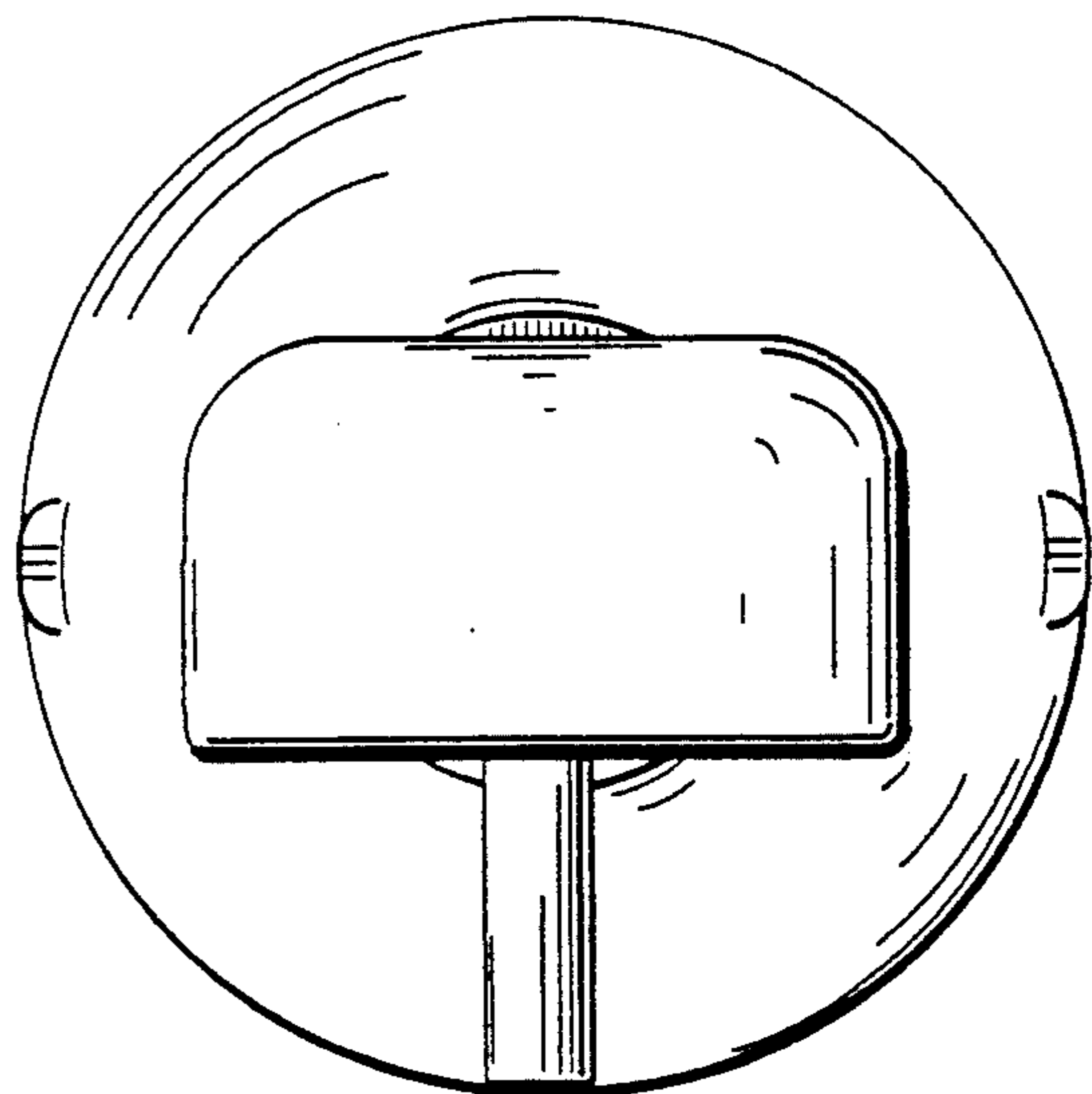

FIG 7

FIG 8

