



US00D346138S

United States Patent [19]

[11] Patent Number: **Des. 346,138**

Camfield et al.

[45] Date of Patent: **** Apr. 19, 1994**

- [54] **BICYCLE**
- [75] Inventors: **David K. Camfield; Daniel G. Hahn,**
both of Olney, Ill.
- [73] Assignee: **Roadmaster Corporation, Olney, Ill.**
- [**] Term: **14 Years**
- [21] Appl. No.: **896,543**
- [22] Filed: **Jun. 10, 1992**
- [52] U.S. Cl. **D12/111**
- [58] Field of Search 280/281.1, 288.1, 288.2,
280/288.3; 180/219; D12/111, 110, 158

- 4,534,578 8/1985 Keller 280/281.1
- 4,613,146 9/1986 Sharp et al. 280/281.1
- 4,776,422 10/1988 Sakuma 180/219
- 4,790,555 12/1988 Nobile 2280/288.4
- 4,813,583 3/1989 Carpenter 224/30 P
- 4,964,484 10/1990 Buell 280/288.2

OTHER PUBLICATIONS

- Brochure, Honda "1991 VFR750F".
- Brochure, Honda "1991 CBR600F2".
- Brochure, Honda "1991 XR200R, XR100R, XR80R and Z50R".
- Catalogue, AMF, Evel Knievel Line, Spirited New Evel Knievel Styles for 1976 (See models L-9240, E-992, E-966).
- Catalogue, AMF, Junior, 1977 Juvenile Wheel Goods, (See models G-992, G-986).
- Catalogue, AMF, Roadmaster, Bicycles for 1977 (See models M-9224, M-9226, M-9236, M-9234).
- Catalogue, AMF, 1978 Juvenile Wheel Goods (See models A-992, A-905).
- Catalogue, AMF, Roadmaster, Bicycles for 1978 (See models P-9240, P-9216, P-9234, P-9214).
- Catalogue, AMF, Junior, Wheel Goods for 1979 (See model B-905).
- Catalogue, AMF, Roadmaster, Bicycles for 1979 (See models R-9214, R-9234, R-9238).
- Catalogue, Bicycles for 1975 (See model K-9234).
- Catalogue, AMF, Junior, 1976 Juvenile Wheel Goods (See model E-986).
- Catalogue, AMF, Roadmaster, Bicycle for 1976 (See models L-9230, L-9234, L-9238, L-9236).

Primary Examiner—Wallace R. Burke
Assistant Examiner—M. Brown
Attorney, Agent, or Firm—Willian Brinks Hofer Gilson & Lione

[56] **References Cited**
U.S. PATENT DOCUMENTS

- D. 93,008 8/1934 Ely D12/111
- D. 138,304 7/1944 Boynton D12/111
- D. 149,408 4/1948 Fuhs D12/111
- D. 166,693 9/1951 Lines D12/111
- D. 170,610 10/1953 Sebel D12/111
- D. 203,146 12/1965 Ryan D12/111
- D. 245,002 7/1977 Carpenter et al. D12/111
- D. 246,170 10/1977 Powers D12/111
- D. 246,779 12/1977 Cognata D12/126
- D. 250,329 11/1978 Breen D12/126
- D. 267,560 1/1983 Matsue D12/110
- D. 270,047 8/1983 Kataoka et al. D12/110
- D. 273,854 5/1984 Ishiyama D12/110
- D. 275,469 9/1984 Morioka et al. D12/110
- D. 291,292 8/1987 Smith et al. D12/111
- D. 294,338 2/1988 Yamada et al. D12/110
- D. 295,274 4/1988 Matsuzaki et al. D12/110
- D. 299,016 12/1988 Kitagawa et al. D12/110
- D. 299,447 1/1989 Sakuma et al. D12/110
- D. 299,816 2/1989 Maruyama et al. D12/110
- D. 312,807 12/1990 Kohama et al. D12/110
- D. 313,380 1/1991 Imai et al. D12/110
- D. 314,167 1/1991 Kolter et al. D12/110
- D. 321,849 11/1991 Abe et al. D12/110
- D. 326,247 5/1992 Hess D12/111
- D. 329,625 9/1992 Mueller et al. D12/111
- D. 332,588 1/1992 Kohama et al. D12/110
- D. 333,641 3/1993 Sakaguchi et al. D12/110
- 1,498,677 6/1924 Bemis et al. 280/281.1
- 2,401,245 5/1946 Hobbs 296/78.1
- 3,690,721 9/1972 Herbert 296/78.1
- 3,891,265 6/1975 Blackburn 296/78.1
- 4,022,487 5/1977 Leahy 280/288.4
- 4,066,290 1/1978 Weigert et al. 296/78.1
- 4,423,901 1/1984 Shumard et al. 296/78.1

CLAIM

[57] The ornamental design for a bicycle, as shown.

DESCRIPTION

FIG. 1 is a left, front perspective view of a bicycle showing our new design;
 FIG. 2 is a left side elevational view thereof;
 FIG. 3 is a right side elevational view thereof;
 FIG. 4 is a front elevational view thereof;
 FIG. 5 is a rear elevational view thereof;
 FIG. 6 is a top plan view thereof; and,
 FIG. 7 is a bottom plan view thereof.

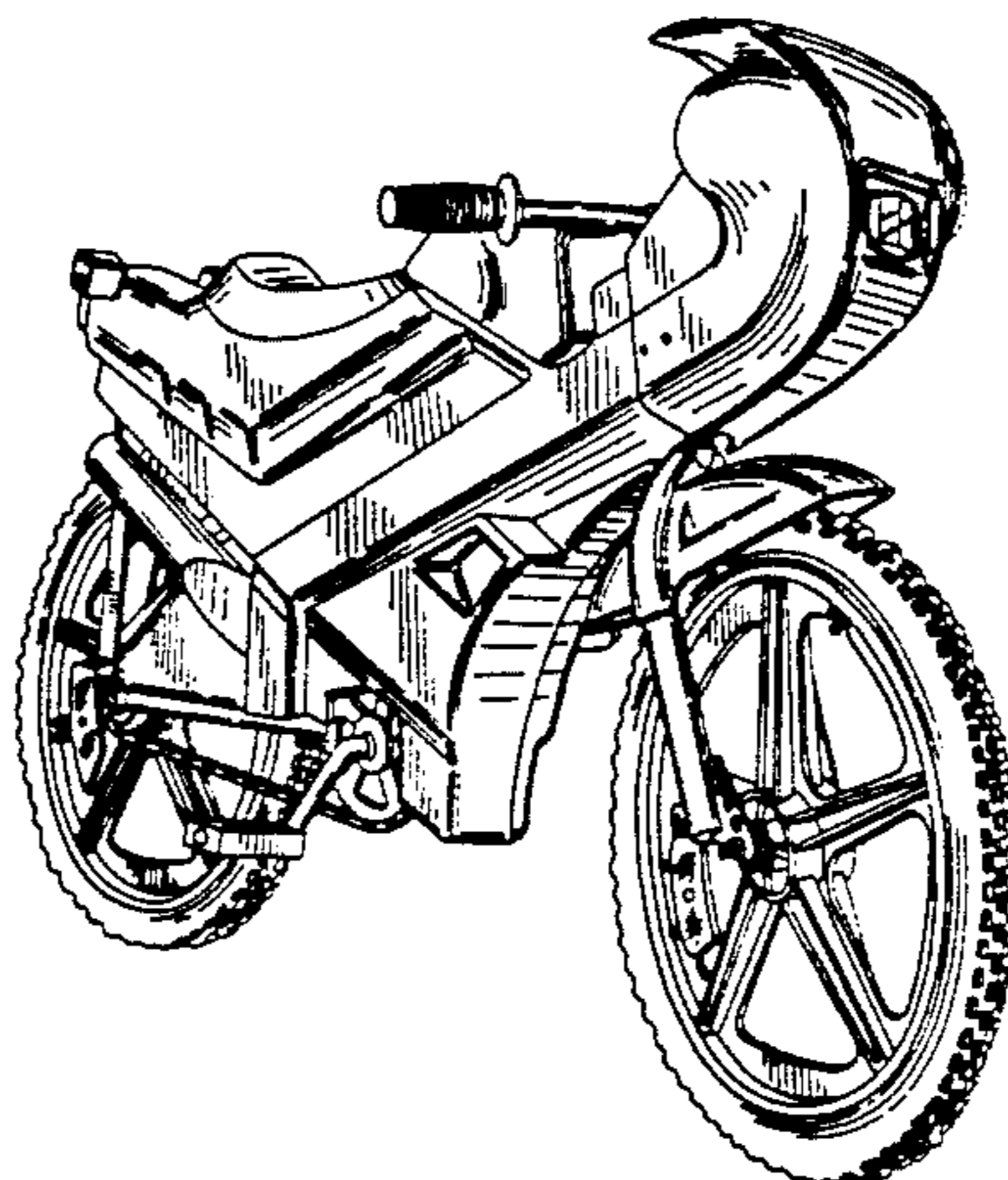
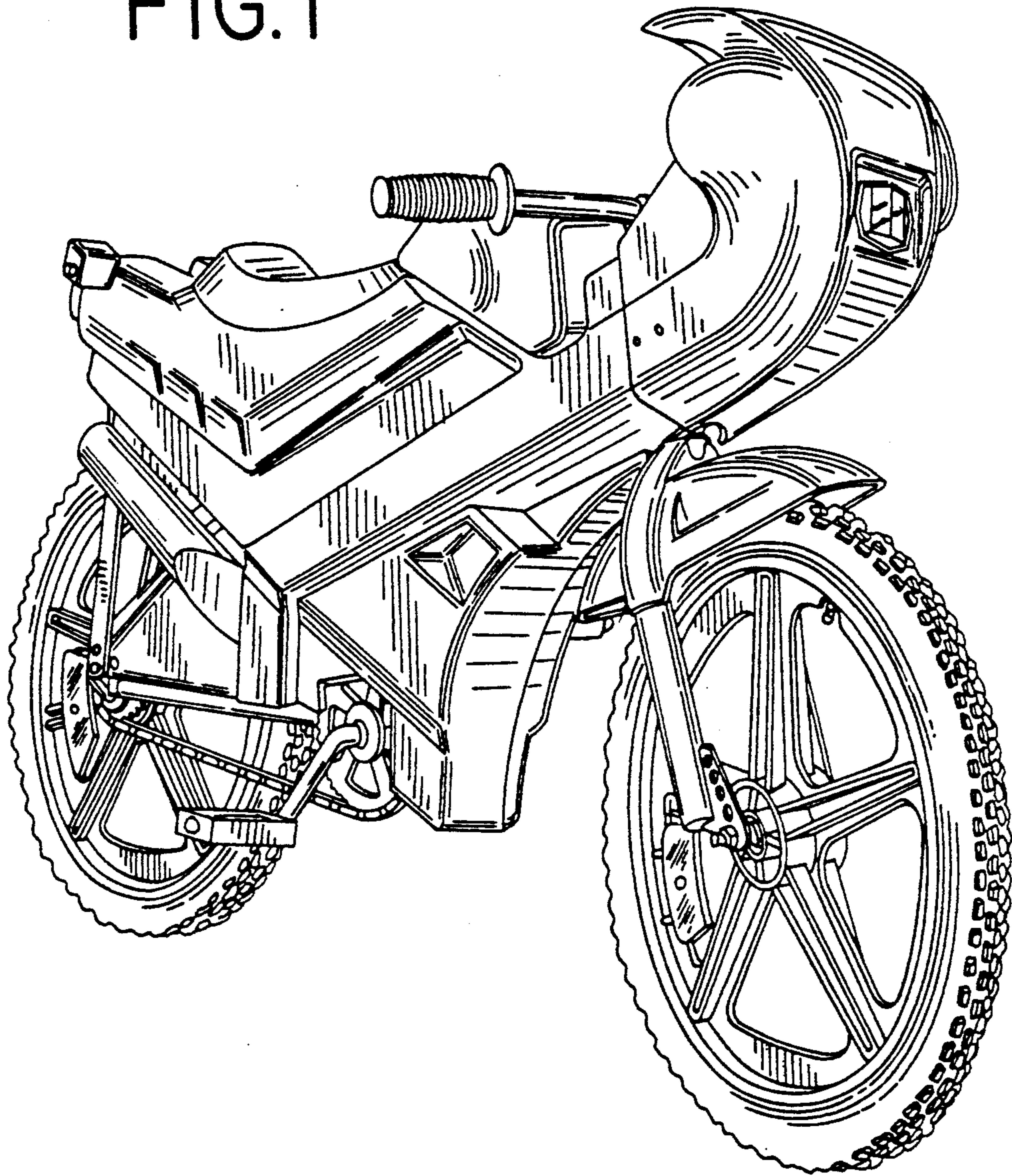

FIG. 1



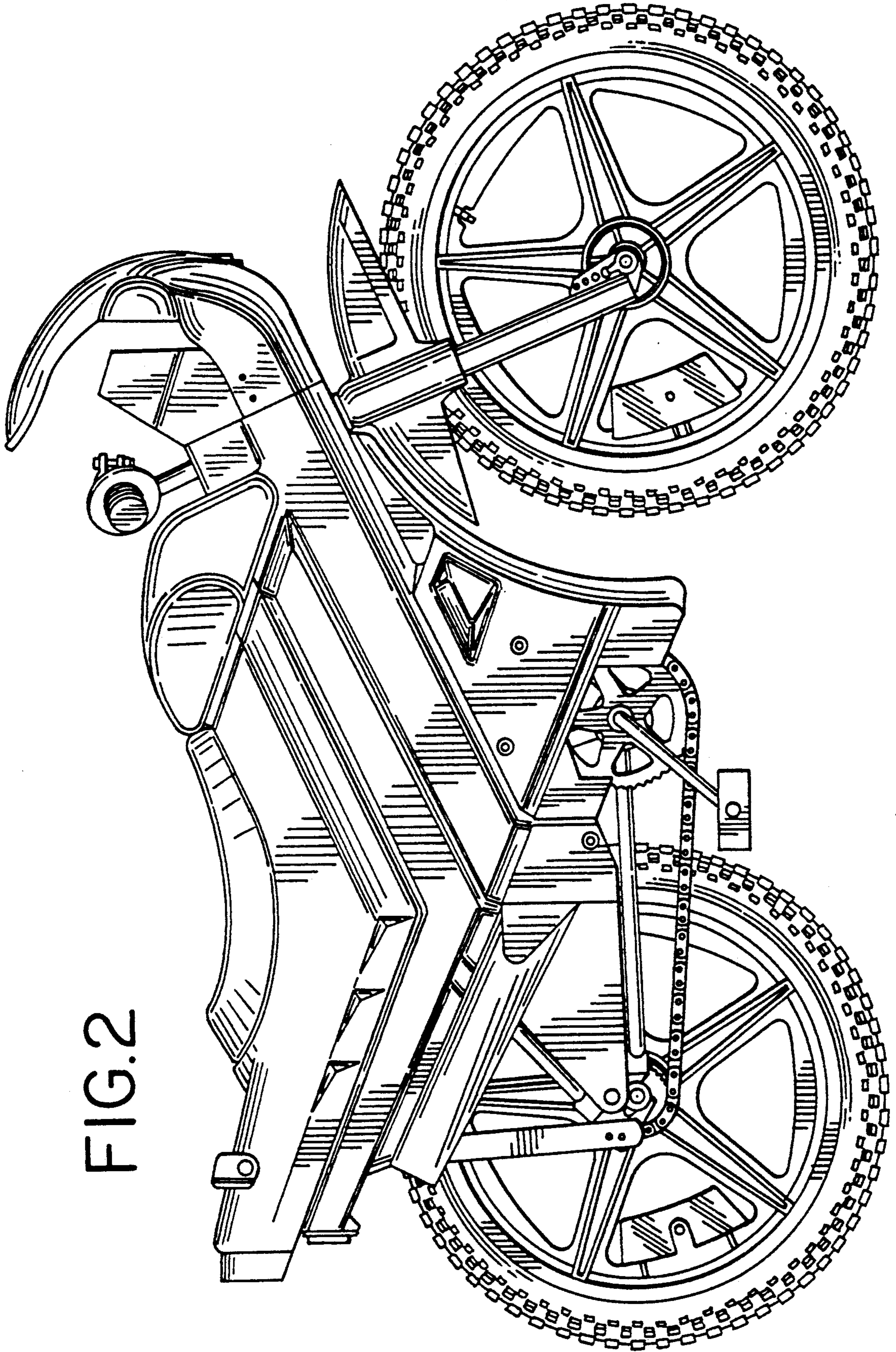

FIG. 2

FIG. 3

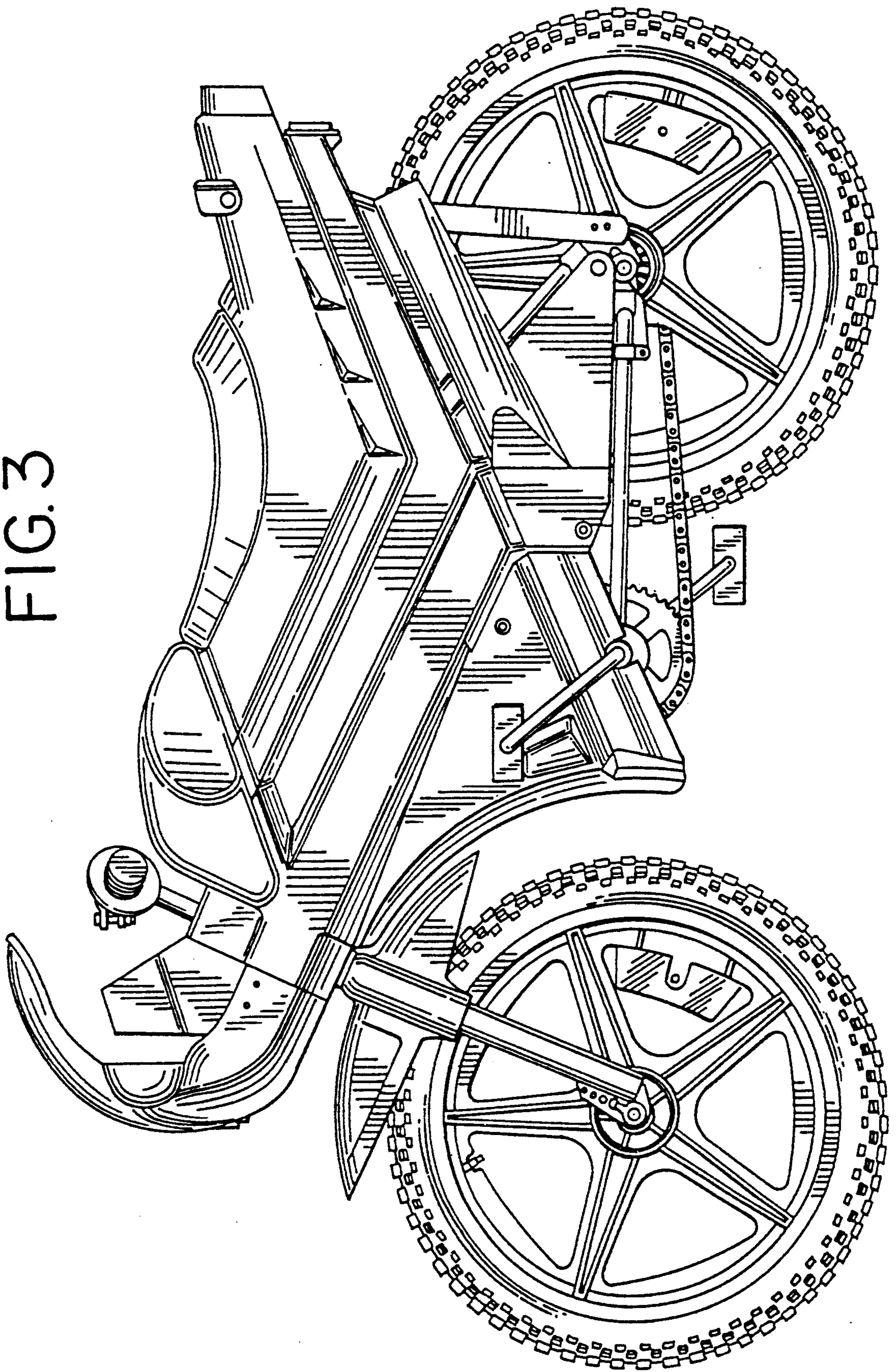

FIG.5

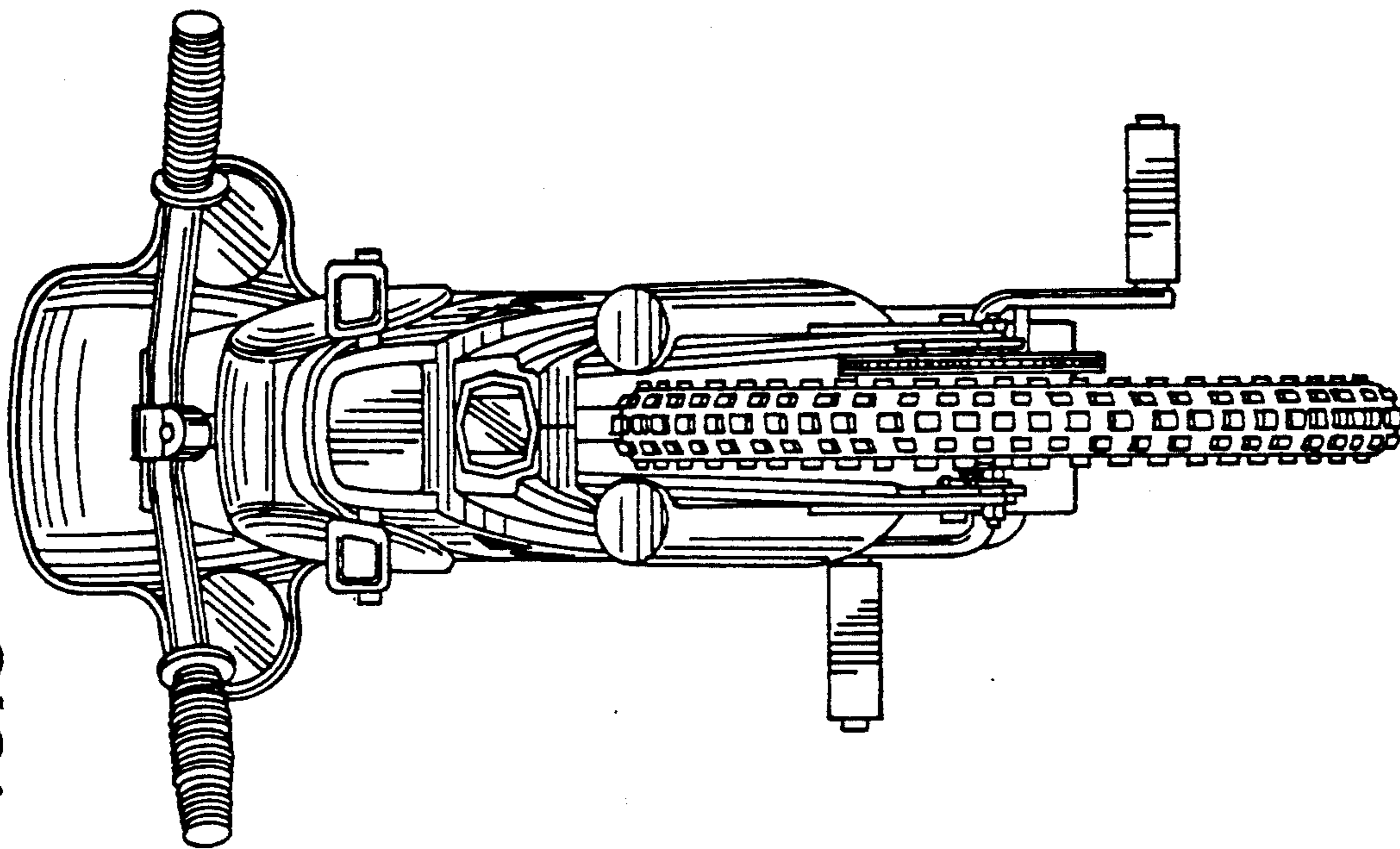
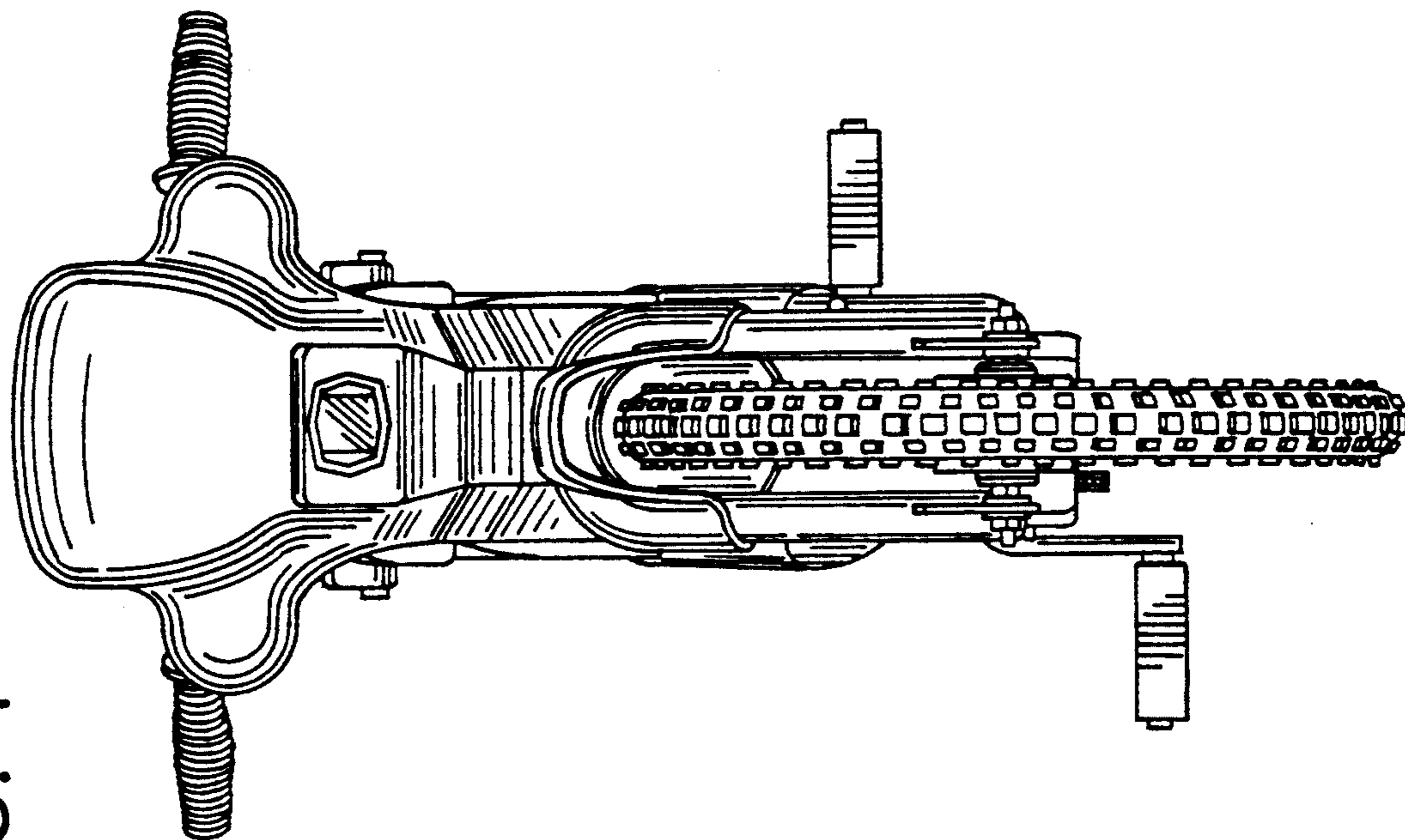

FIG.4



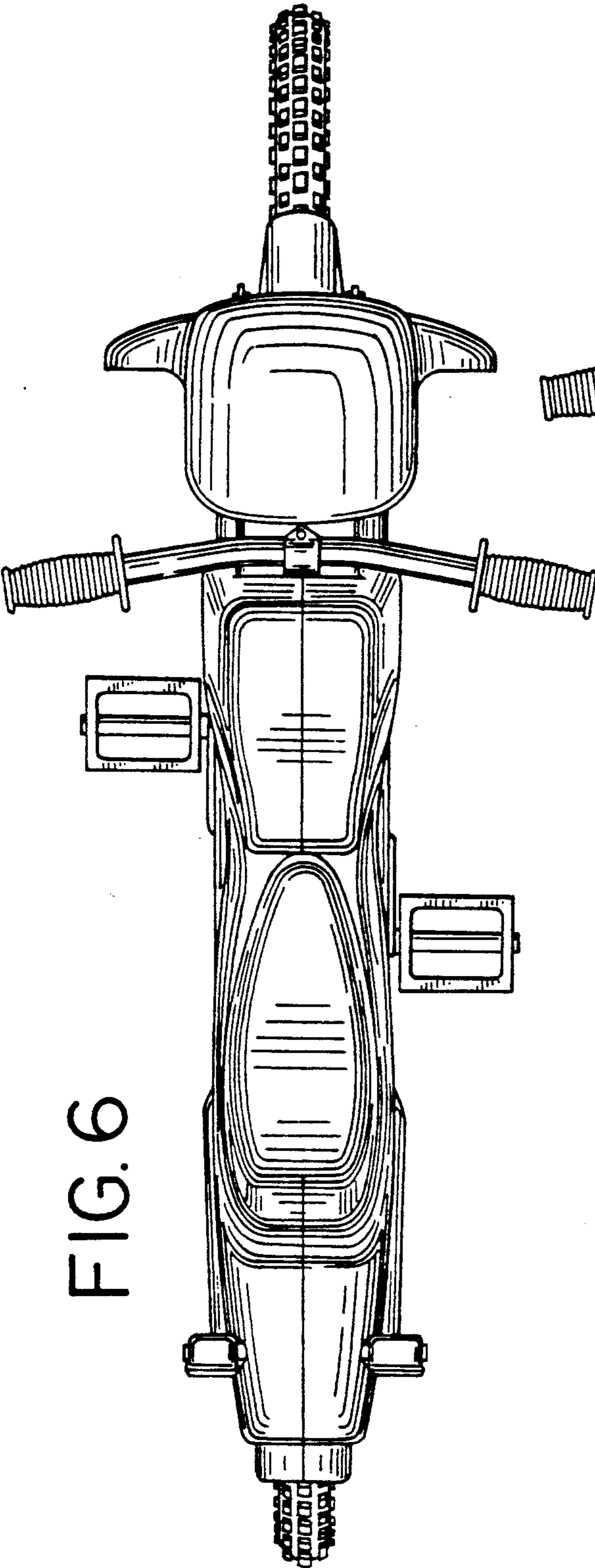

FIG. 6

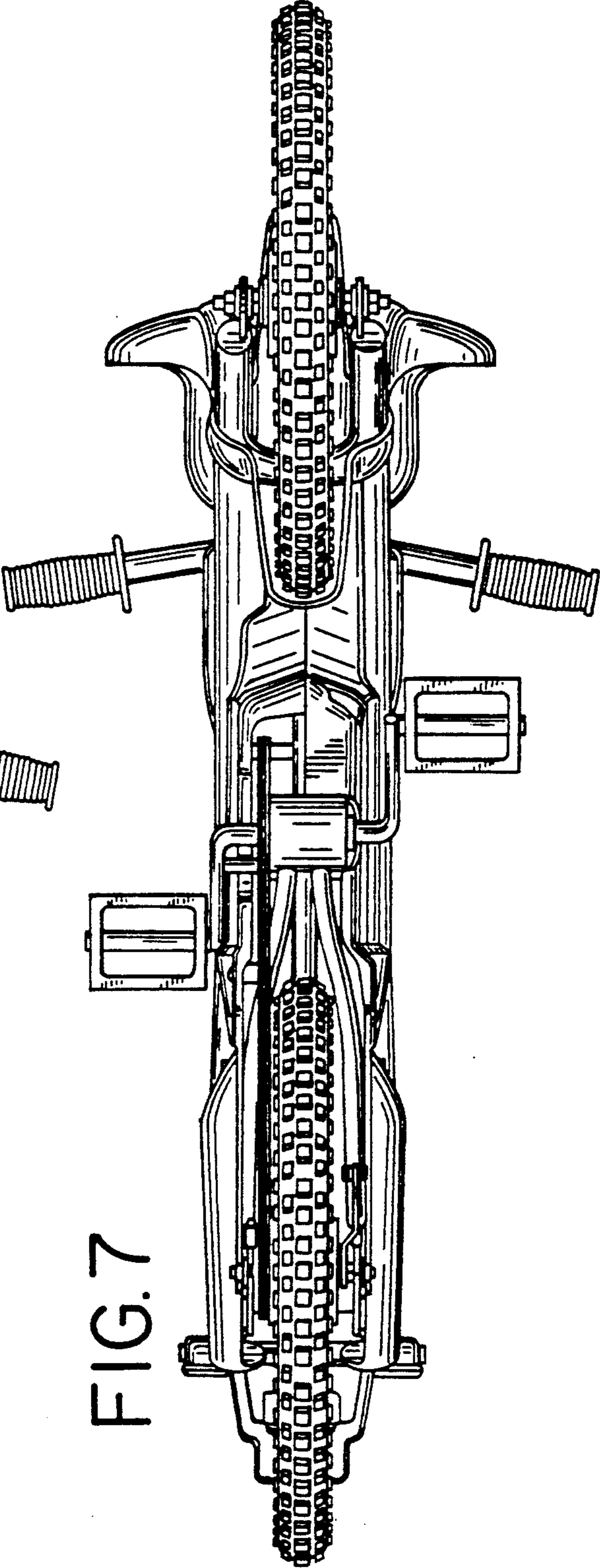

FIG. 7

UNITED STATES PATENT AND TRADEMARK OFFICE
CERTIFICATE OF CORRECTION

PATENT NO. Des. 346,138
DATED April 19, 1994
INVENTOR(S) David K. Camfield et al.

It is certified that error appears in the above-identified patent and that said Letters Patent is hereby corrected as shown below:

On the title page, item [56]:

In column 2, under "OTHER PUBLICATIONS", line 7, delete "Eα992" and insert --E-992--.

Signed and Sealed this

Twenty-second Day of November, 1994

Attest:



BRUCE LEHMAN

Attesting Officer

Commissioner of Patents and Trademarks