



US00D346066S

United States Patent [19] Smith

[11] Patent Number: Des. 346,066

[45] Date of Patent: ** Apr. 19, 1994

[54] FLOOR TO SEAT VEHICLE CONSOLE

[75] Inventor: Daniel G. Smith, Arlington, Tex.

[73] Assignee: Texas Saddlebags, Inc., Arlington, Tex.

[**] Term: 14 Years

[21] Appl. No.: 236

[22] Filed: Oct. 8, 1992

[52] U.S. Cl. D12/416; D12/419

[58] Field of Search D3/40, 35; 224/42.11, 224/42.42, 275; 296/37.8, 37.13-37.16; D12/155

[56] References Cited

U.S. PATENT DOCUMENTS

D. 247,929	5/1978	Wynn	D3/40
D. 248,056	5/1978	Nepper	D3/40
D. 271,634	12/1983	Rockwell	D3/40
D. 317,674	6/1991	Smith	D3/40
D. 328,973	9/1992	Mankey	D3/40

OTHER PUBLICATIONS

"Consoles For Pickups, Minivans & Cars" Saddlebags—Rev. Apr. 1992.

"Concept 2000 Consoles"—Steel Horse pp. 9-10 (date unknown).

"Consoles" Wolf—p. 9 (date unknown).

Primary Examiner—Louis S. Zarfes

Attorney, Agent, or Firm—Daniel Rubin

[57] CLAIM

The ornamental design for a floor to seat vehicle console, as shown and described.

DESCRIPTION

FIG. 1 is a top perspective view of a floor to seat vehicle console showing my new design in use;

FIG. 2 is a left side elevation view thereof the right side being a mirror image thereof;

FIG. 3 is a front elevational view thereof;

FIG. 4 is a rear elevational view thereof;

FIG. 5 is a top plan view thereof; and,

FIG. 6 is a bottom plan view thereof.

The broken line showing of a vehicle interior in FIG. 1 is for illustrative purposes only and form no part of the claimed design.

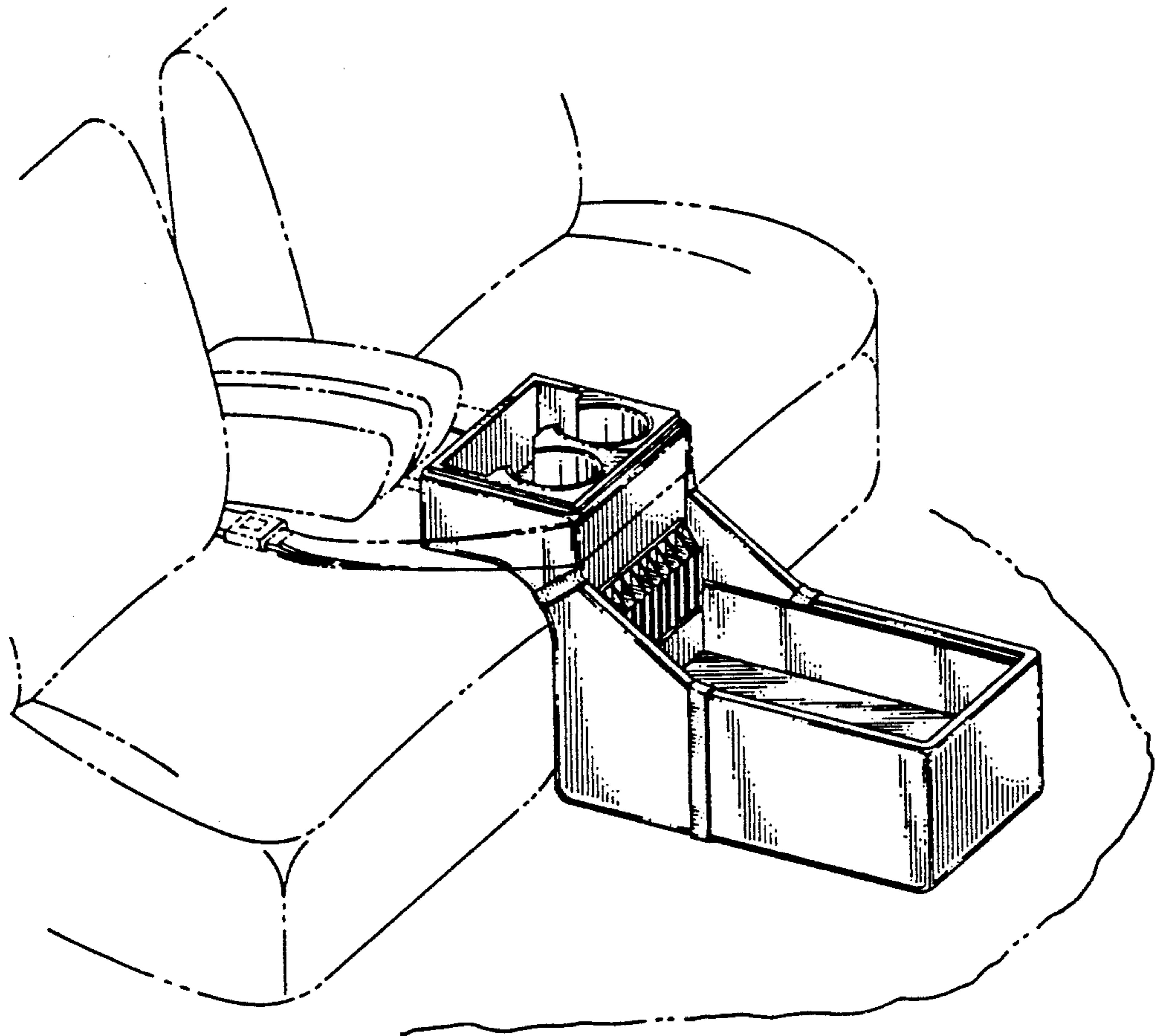

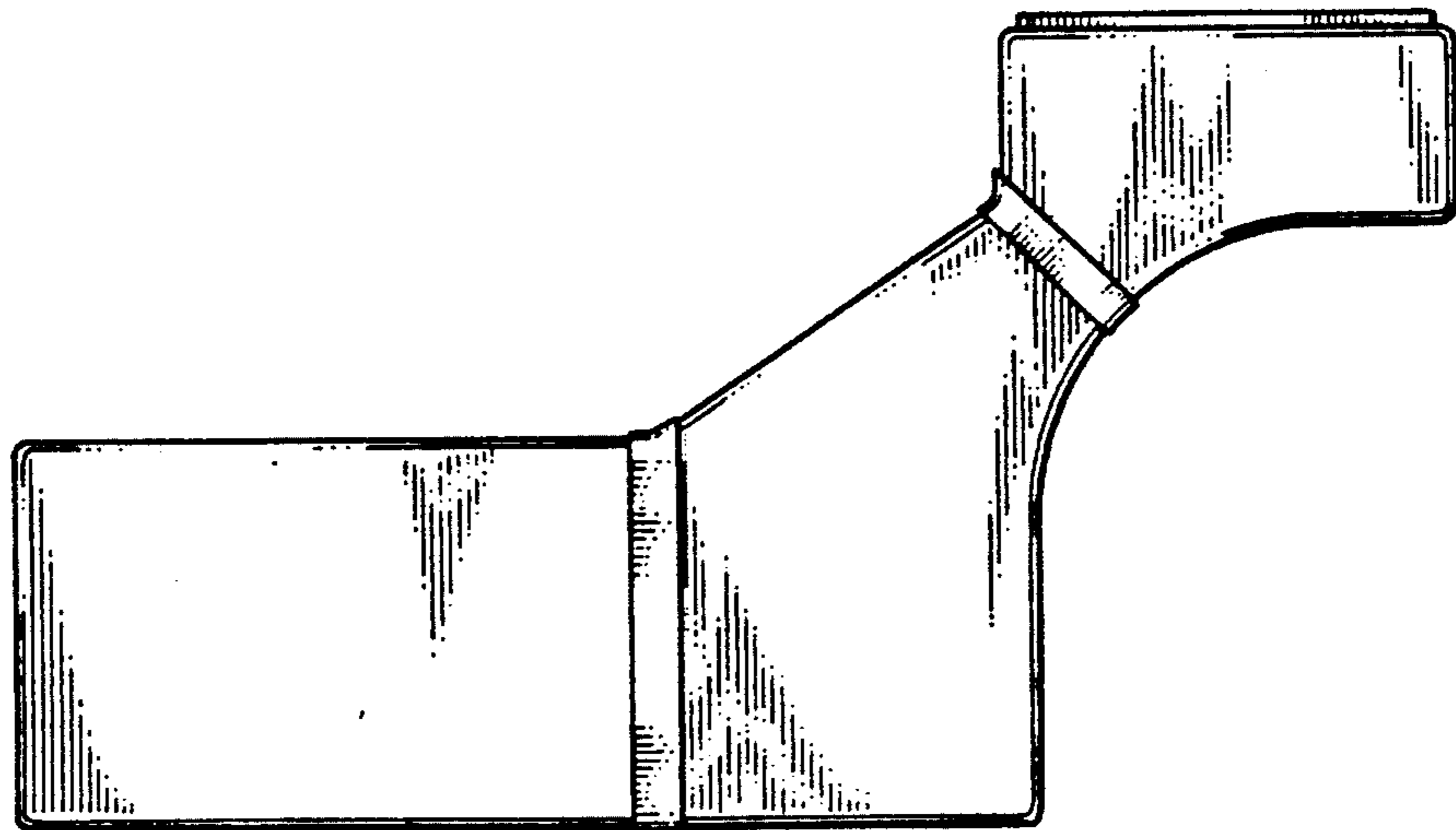
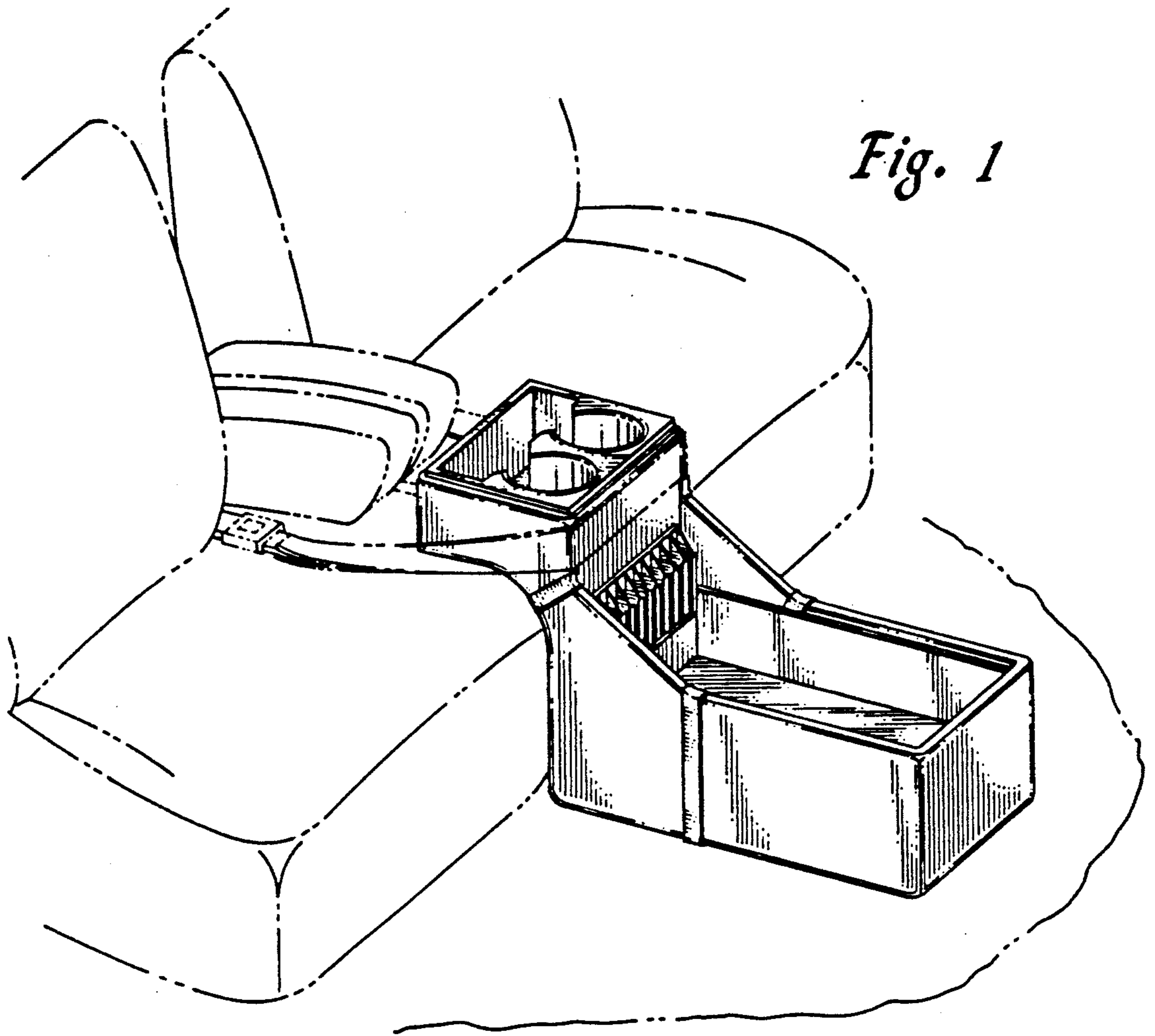

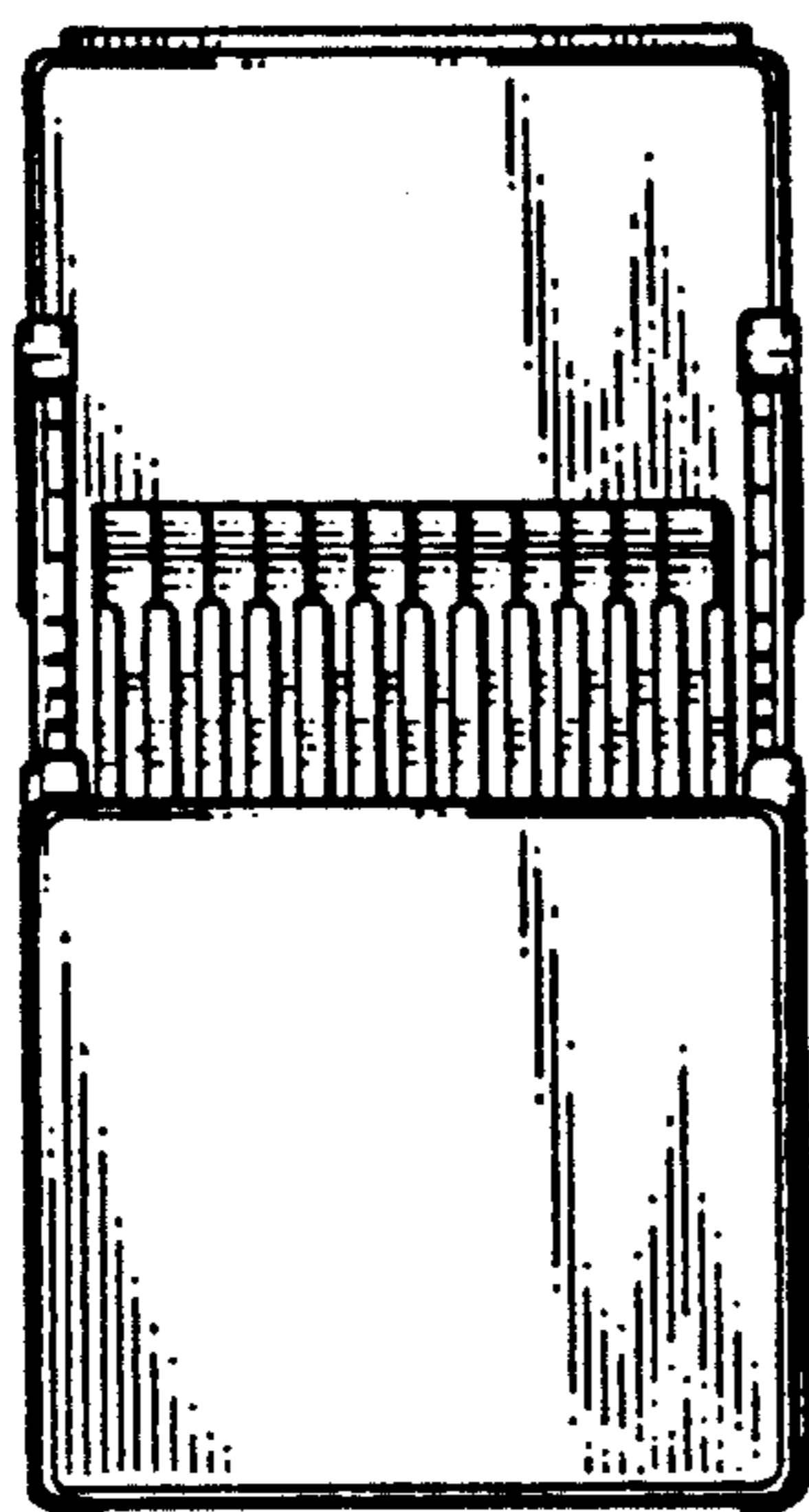

Fig. 3

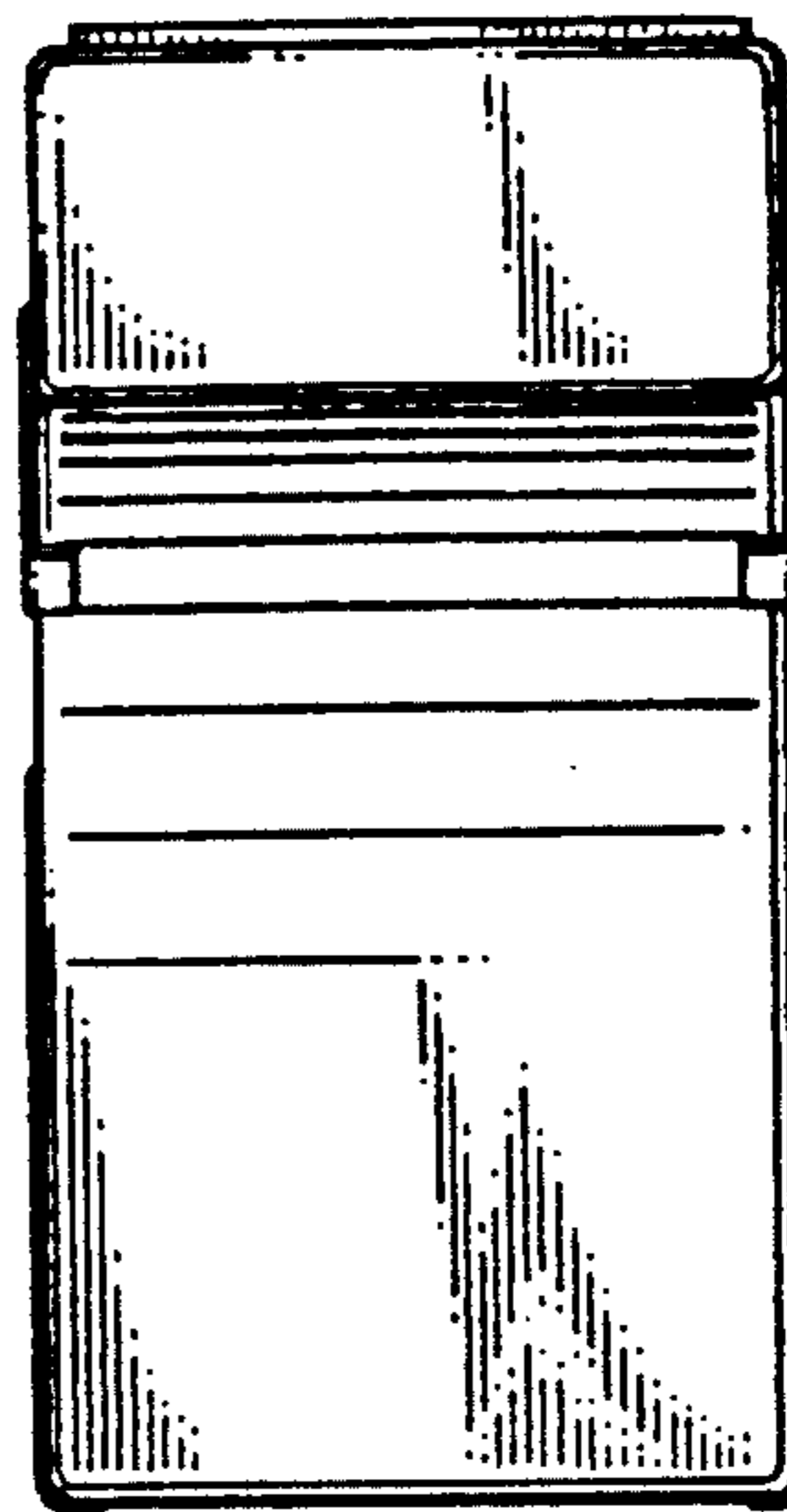

Fig. 4

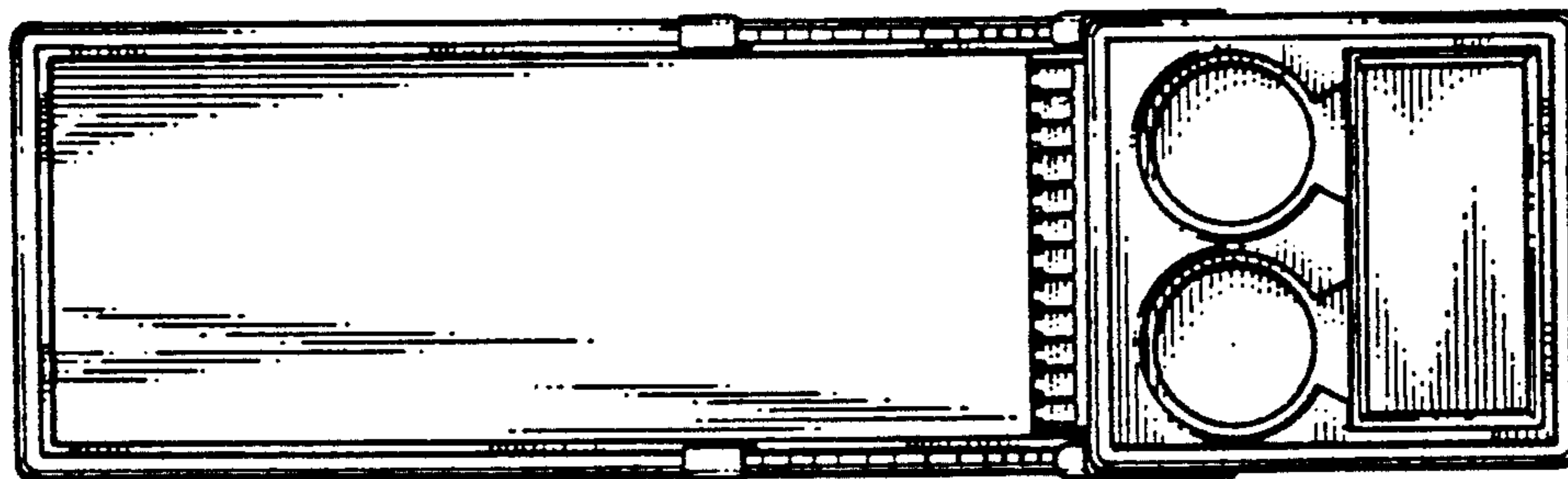

Fig. 5



Fig. 6