



US00D345992S

United States Patent [19]

[11] Patent Number: **Des. 345,992**

Mohsen

[45] Date of Patent: **** Apr. 12, 1994**

[54] CAUTION TAG

| | | | |
|-----------|---------|-----------|--------|
| 1,745,230 | 1/1930 | Proskauer | 40/299 |
| 2,655,747 | 10/1953 | Duskin | 40/6 |
| 2,811,797 | 11/1957 | Jeeter | D20/22 |

[76] Inventor: **Jafar Mohsen**, 409 Honker La., Suisun, Calif. 94585

Primary Examiner—Wallace R. Burke
Assistant Examiner—Marcus Jackson
Attorney, Agent, or Firm—Hugh E. Smith

[**] Term: **14 Years**

[21] Appl. No.: **8,314**

[57] CLAIM

[22] Filed: **May 13, 1993**

The ornamental design for a caution tag, as shown and described.

[52] U.S. Cl. **D20/22**

[58] Field of Search 40/1, 1.5, 1.6, 124, 40/124.1, 299, 5, 6, 647, 649, 651, 650, 652, 656, 658, 662, 666, 669; D20/10, 22, 23, 27, 28, 40, 42

DESCRIPTION

FIG. 1 is a front elevational view of the caution tag showing my new design, with the broken line showing for illustrative purposes only and forming no part of the claimed design;
FIG. 2 is a rear elevational view thereof;
FIG. 3 is a left side elevational view thereof;
FIG. 4 is a right side elevational view thereof;
FIG. 5 is a top plan view thereof;
FIG. 6 is a bottom plan view thereof; and,
FIG. 7 is an isometric view thereof.

[56] References Cited

U.S. PATENT DOCUMENTS

| | | | |
|------------|--------|--------------|--------|
| 141,205 | 7/1873 | Curless | 40/6 |
| 247,165 | 9/1881 | Chantrell | D20/22 |
| D. 287,864 | 1/1987 | Perfect | D20/22 |
| D. 314,015 | 1/1991 | Hickman, Sr. | D20/27 |
| D. 317,181 | 5/1991 | Nozawa | D20/22 |

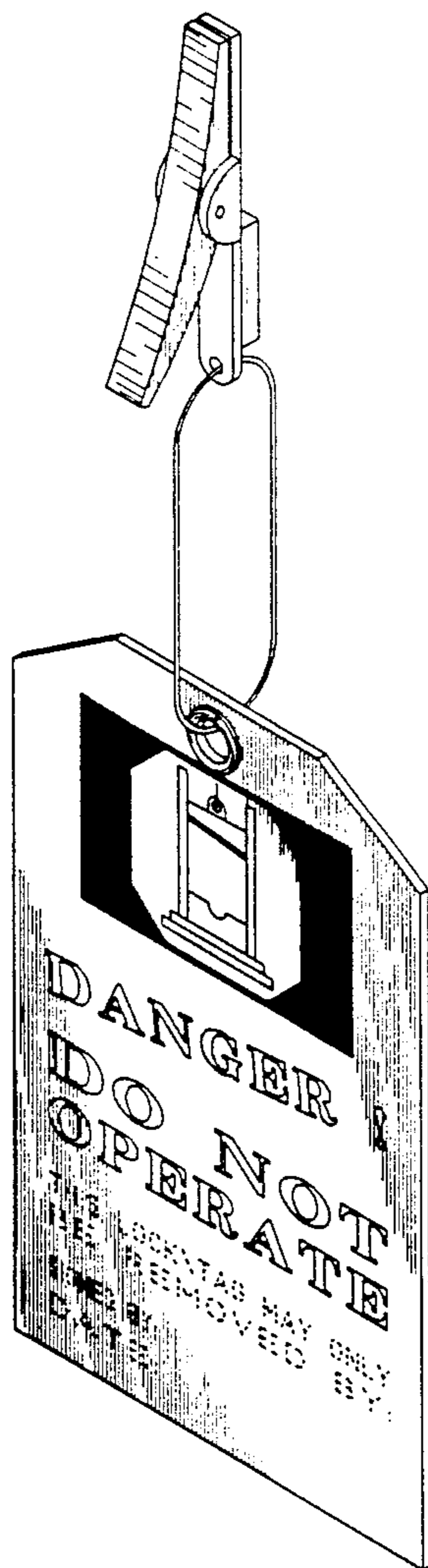

FIG. 1

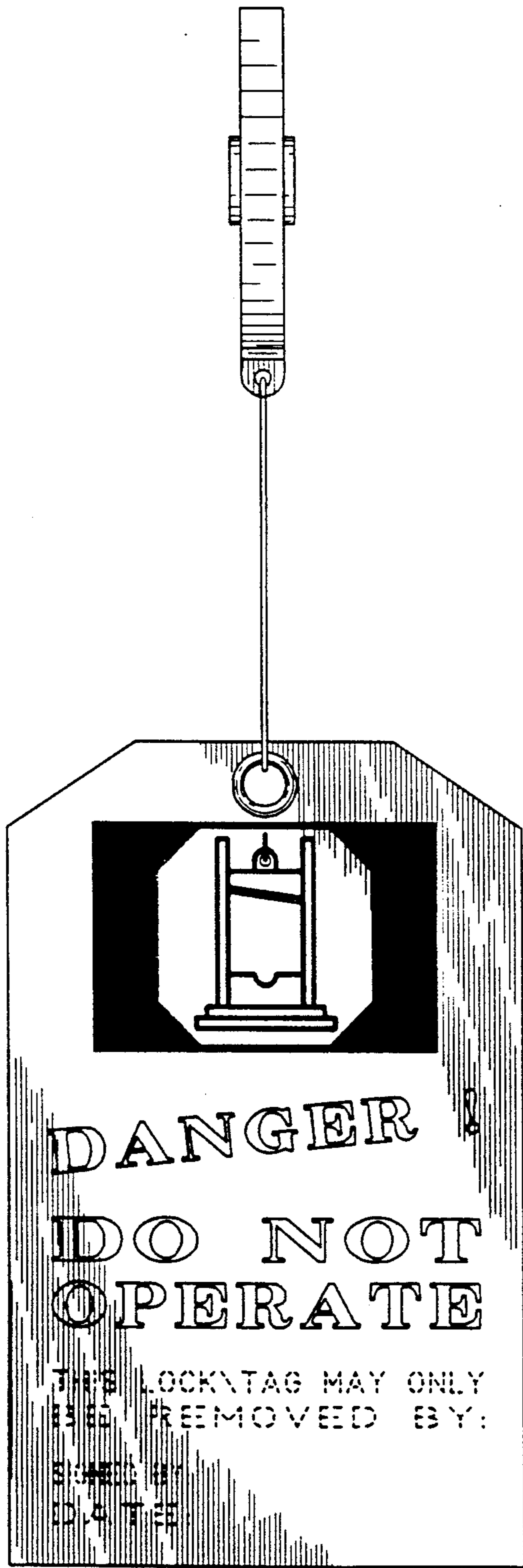

FIG. 2

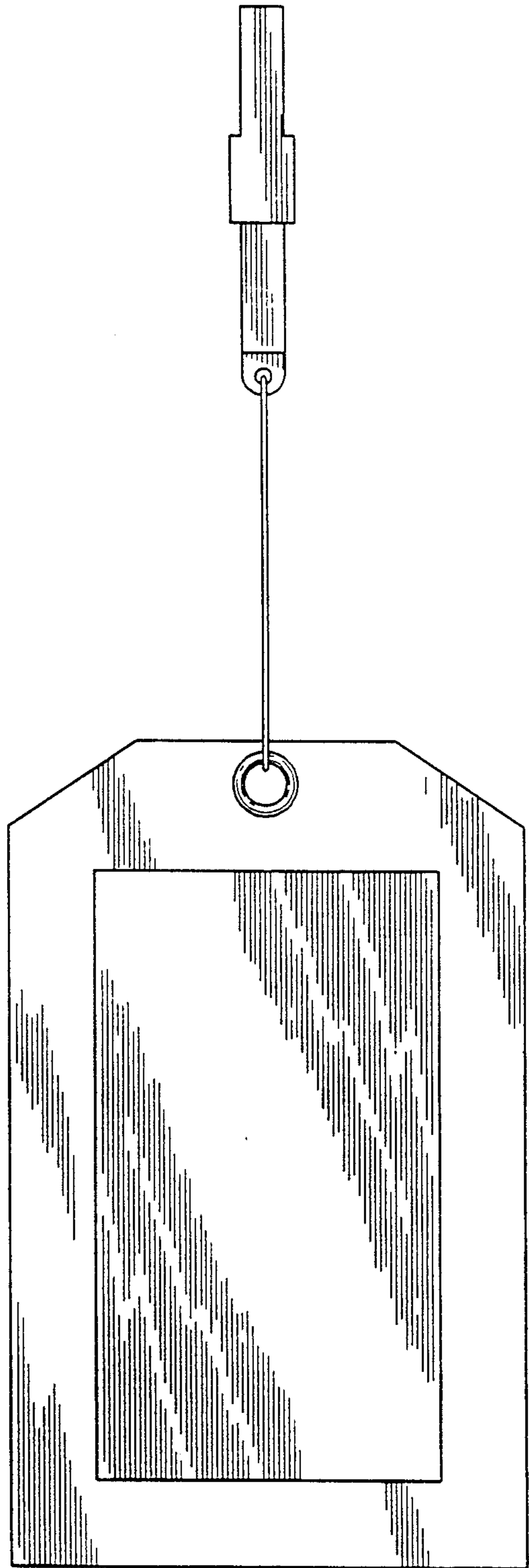

FIG. 3

FIG. 4

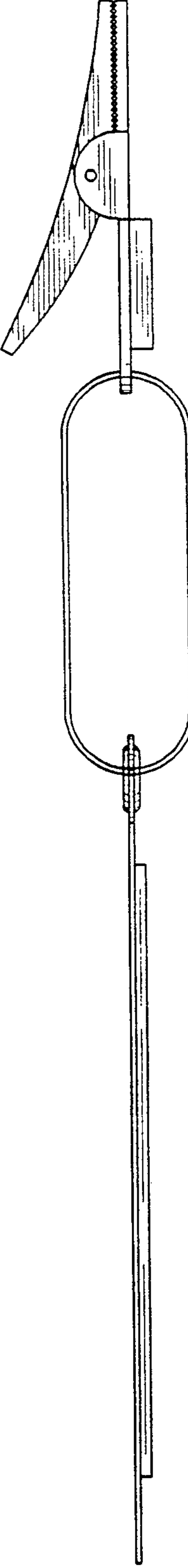
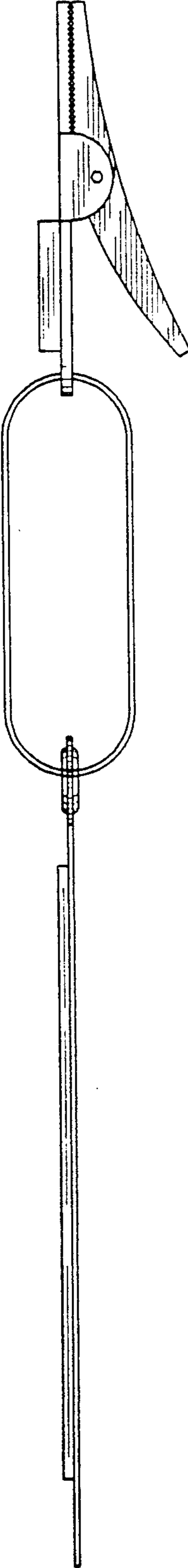

FIG. 5

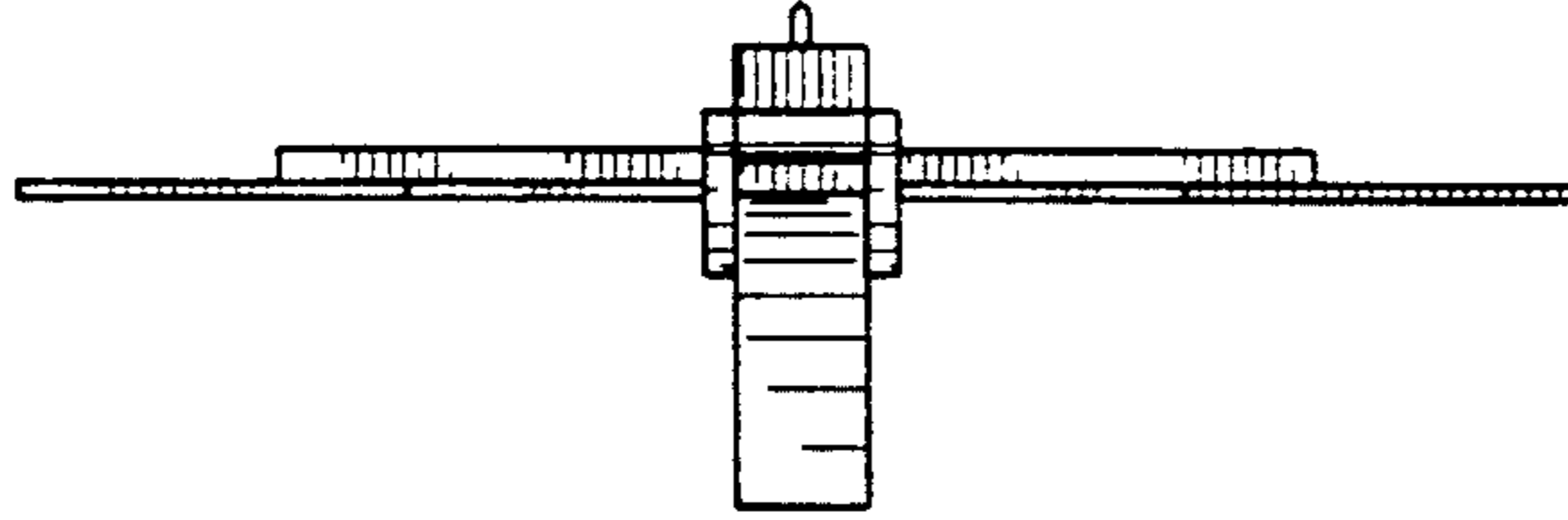

FIG. 6

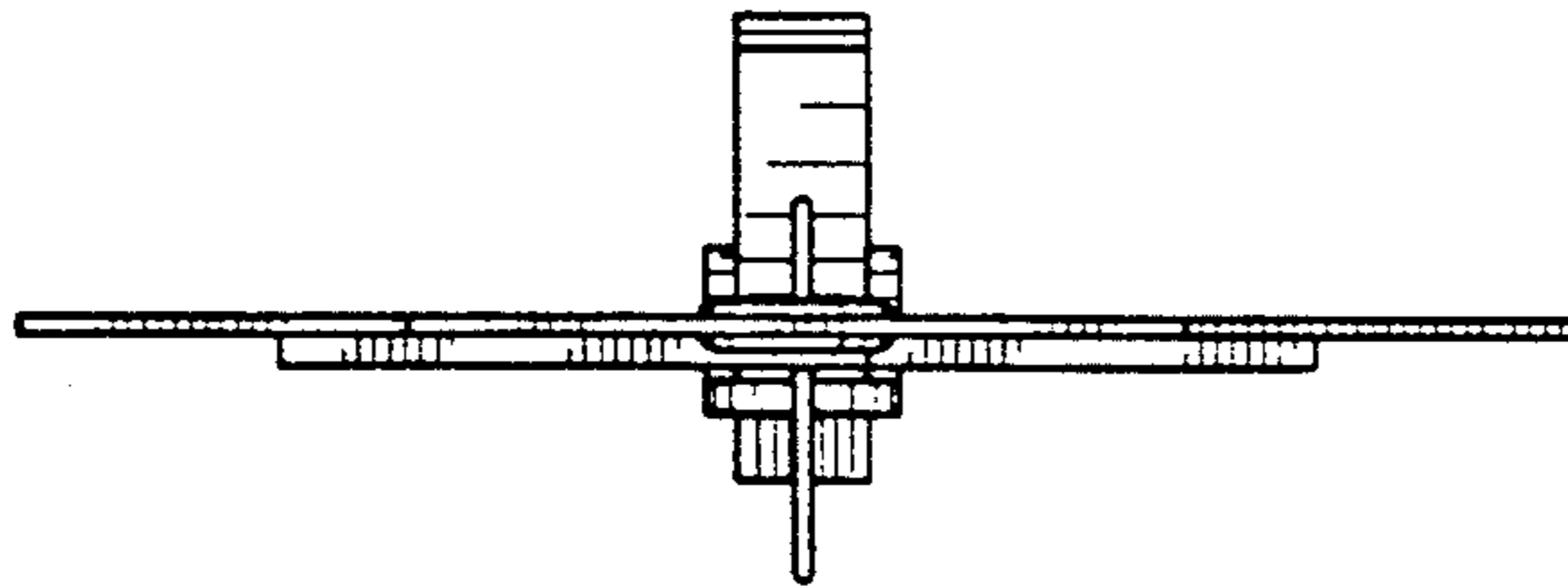

FIG. 7

